

HP-3 Indirect/Direct with Mitered Corners Installation Instructions

Step 1 - Mounting & Suspension

Mounting Options

Option 1 T-Bar Mounting - GridBox™ and Caddy Clips

- Install GridBox™ and electrical conduit at feed locations.
- Install caddy clips at mounting point locations.
- All caddy clips are to be secured to structure, per local building codes.

Option 2 Drywall (C4) or other hard surfaces* - J-Box and Anchor Bolts

- Install J-Box and electrical conduit at feed locations.
- Install anchor bolts at mounting point locations.
- All anchor bolts are to be secured to structure, per local building codes.

*Other hard surfaces include: wood, sheet metal panels, steel beams, concrete or masonry. Use hardware appropriate for each surface material type.

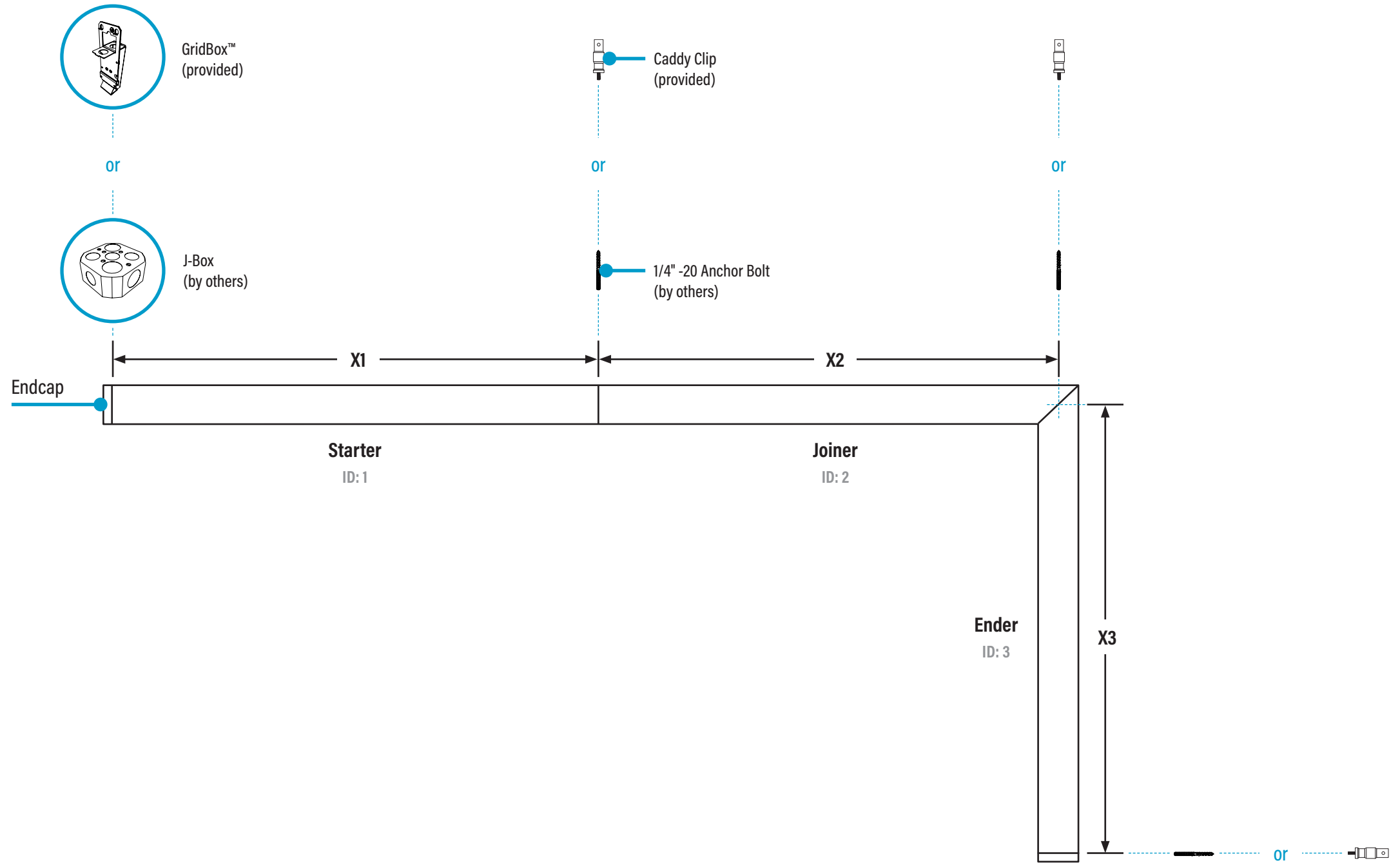

Suspension Locations

X = Suspension Dimensions

Refer to Record Drawings and building plans to determine exact mounting, suspension points, and power feed locations.

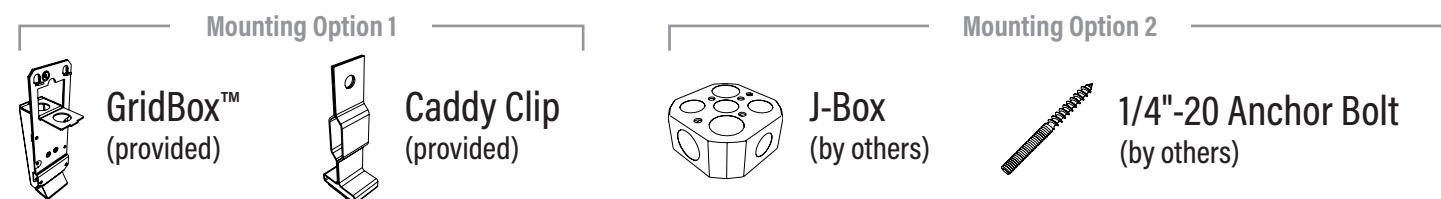

HP-3 Indirect/Direct with Mitered Corners Installation Instructions

Step 2 - Identification & Preparation

A. Identify Luminaires



CAUTION

Arrange luminaires in order according to ID# at their install locations.

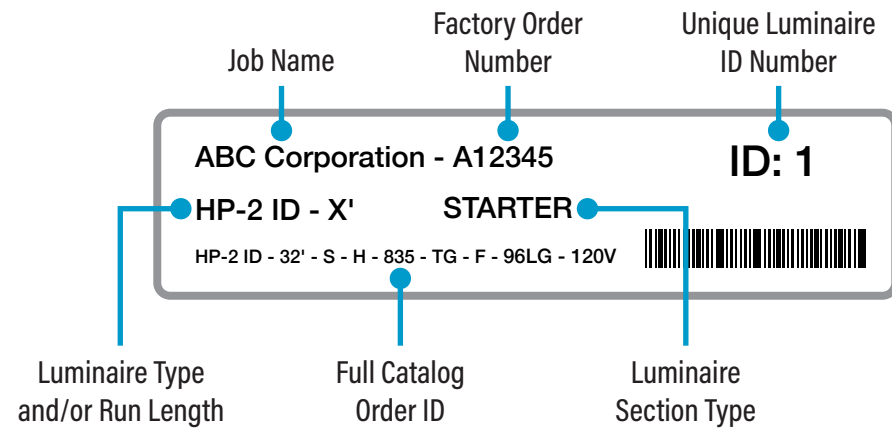

- Identify all luminaires by their ID label that can be found on the box, the diffuser, and inside the luminaire.
- NOTE:** Exact location of labels in these areas may vary.
- Remove all luminaires from their box.
- Refer to Record Drawings that can be found in the hardware kit.

B. Remove Downlight Diffusers

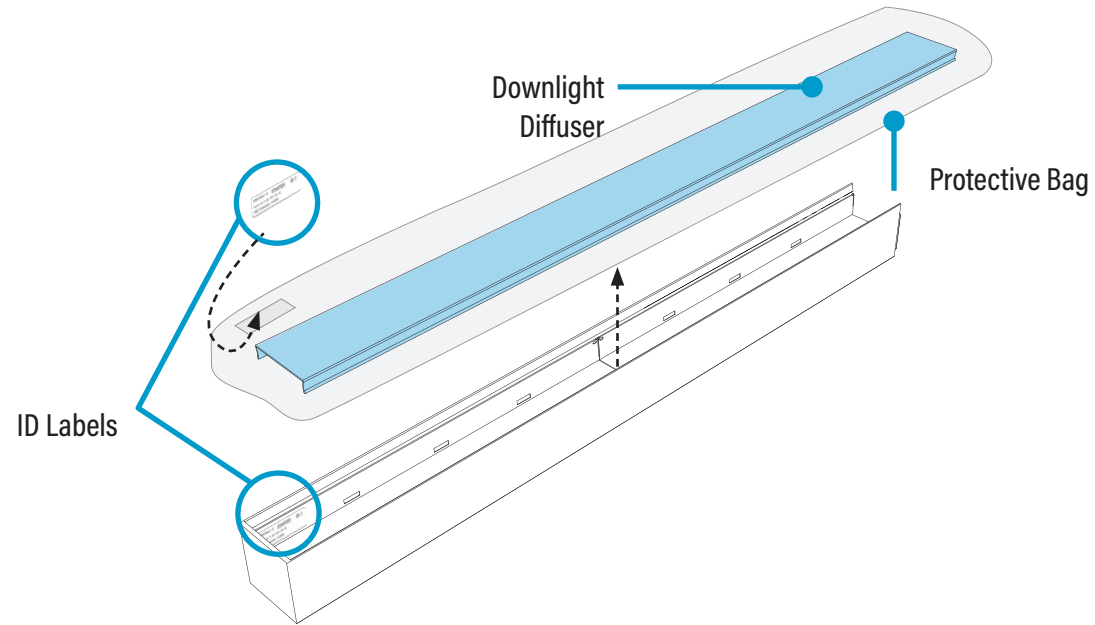

- Carefully remove all downlight diffusers, keeping them inside their protective bags.
- Set aside all downlight diffusers to prevent from getting dirty or damaged.
- Ensure downlight diffusers can be identified back to their corresponding luminaire.

C. Remove Uplight Diffuser

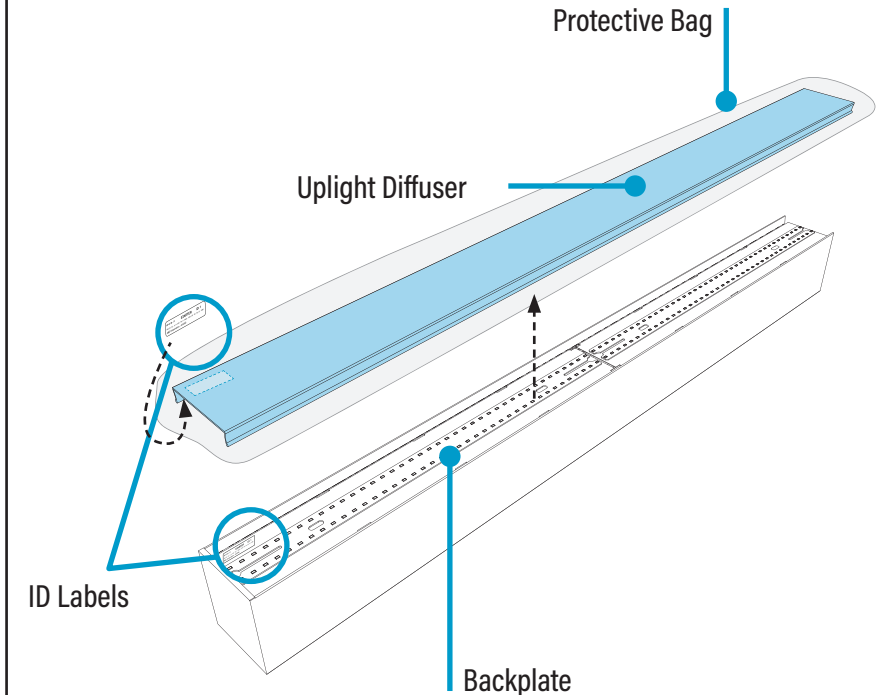

- Carefully remove all uplight diffusers, keeping them inside their protective bag.
- Set aside all uplight diffusers to prevent from getting dirty or damaged.
- Ensure uplight diffusers can be identified back to their corresponding luminaire.

Kitted Hardware

- Finelite has provided items listed here, with their Finelite part numbers. These items can be found in separate boxes shipped with the luminaire.
- Account for all parts and set aside until they are needed.
- All other hardware needed for this installation will be by others.

<p>GridBox™ Part# 89159</p> <p>Dual GridBox™ Part# 89199 Mounting & Suspension p. 2, Step 1</p> <p>Caddy Clip C1 Ceiling - Part# 94001 C2 Ceiling - Part# 94020 C3 Ceiling - Part# 94029 Mounting & Suspension p. 2, Step 1</p>	<p>Mounting Option 1</p> <p>3-1/2" Canopy Part# 89191</p> <p>3-1/2" Dual Feed Canopy Part# 89192 Mounting Starter to Structure p. 4, Step 3 Joining Luminaires p. 5, Step 4 Joining Mitered Corners p. 8, Step 7</p> <p>2" T-Bar Support Canopy Part# 89193 Mounting Starter to Structure p. 4, Step 3 Joining Luminaires p. 5, Step 4 Joining Mitered Corners p. 8, Step 7</p>	<p>Mounting Option 2</p> <p>5" Canopy Part# 94085</p> <p>5" Dual Feed Canopy Part# 94145 Mounting Starter to Structure p. 4, Step 3 Joining Luminaires p. 5, Step 4 Joining Mitered Corners p. 8, Step 7</p> <p>2" Drywall Support Canopy Part# 94017 Mounting Starter to Structure p. 4, Step 3 Joining Luminaires p. 5, Step 4 Joining Mitered Corners p. 8, Step 7</p>	<p>Cable Bushing Part# 94014</p> <p>Aircraft Cable 50" - Part# 94515-12 (Std.) 100" - Part# 94515-14 150" - Part# 94515-18 Mounting Starter to Structure p. 4, Step 3 Joining Luminaires p. 5, Step 4 Joining Mitered Corners p. 8, Step 7</p> <p>Safety Crimp Part# 94514 Closing Luminaires p. 10, Step 9</p>	<p>Gripper Part# 68129 Mounting Starter to Structure p. 4, Step 3 Joining Luminaires p. 5, Step 4 Joining Mitered Corners p. 8, Step 7</p>	<p>Slip Ring w/ Set Screw Part# 94015 Mounting Starter to Structure p. 4, Step 3 Joining Luminaires p. 5, Step 4 Joining Mitered Corners p. 8, Step 7</p>
--	---	---	--	---	--

HP-3 Indirect/Direct with Mitered Corners Installation Instructions

Step 3 - Mounting Starter to Structure

A. Mount Starter to Structure

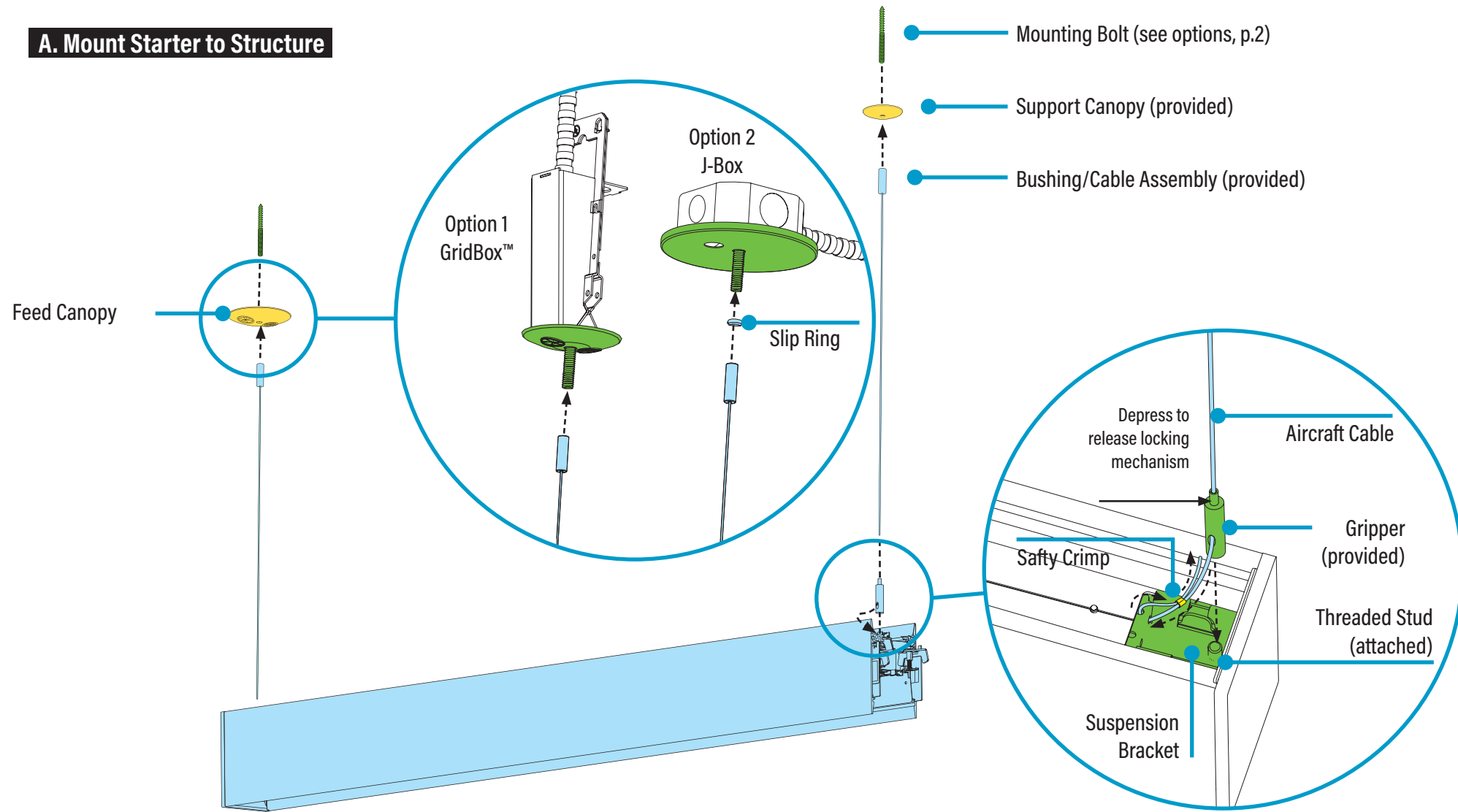

- Slide canopy appropriate for electrical type options onto mounting bolt (anchor bolt or caddy clip bolt).
- (Option 2 only) Thread the Slip Ring onto anchor bolts and secure it with a set screw at both mounting locations.
- Thread the bushing/cable assembly onto mounting bolts.
- Attach grippers onto threaded studs found on the end plates of the starter luminaire.
- While properly supporting the luminaire, maneuver the luminaire to the ceiling.

- Depress the top of the gripper to feed the Aircraft Cable through and lead into the feed hole.
- Loop cable through Safety Crimp and holes in Suspension Bracket, then back through Safety Crimp.
- Crimp, then cut the excess cable.

B. Make Electrical Connections

WIRING LEGEND		
Black	Hot	Line Voltage
White	Neutral	Line Voltage
Green	Ground	
Pink	Dimming	0-10V DC
Purple	Dimming	0-10V DC

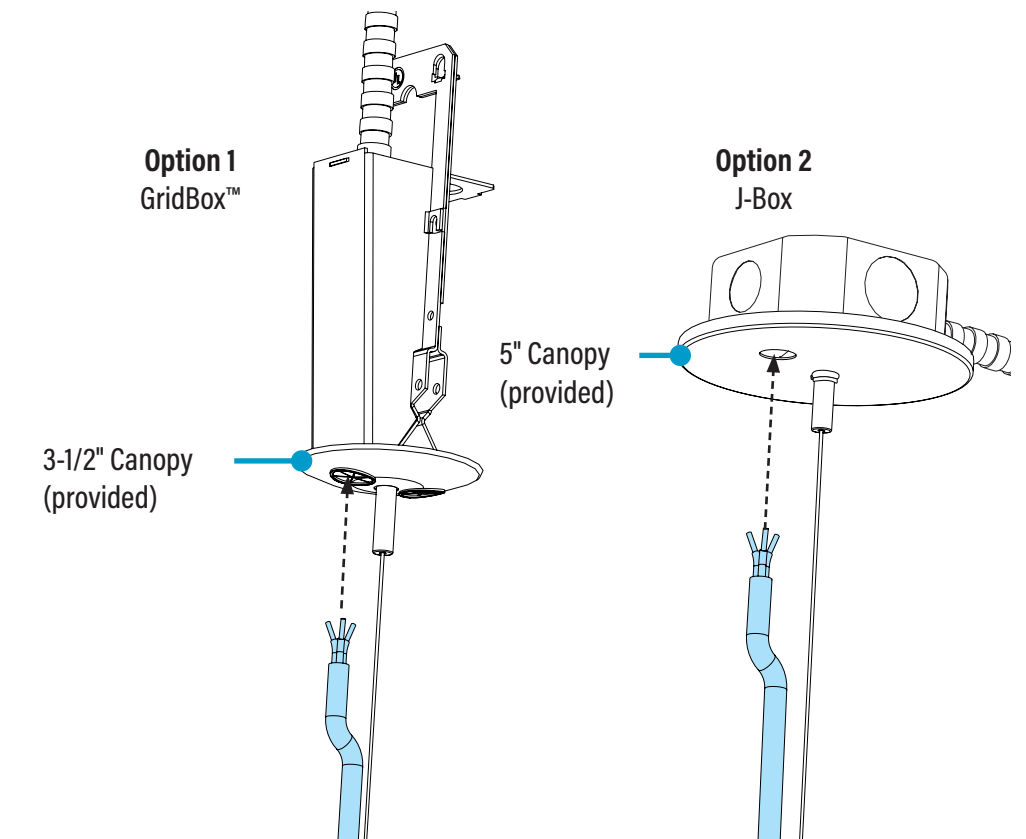

- (Option 1) Feed power cord through the 3-1/2" canopy and connect wires inside the GridBox™.
- (Option 2) Feed power cord through the 5" canopy and connect wires inside the J-Box.
- **CRITICAL:** If installing mitered corner, PROCEED TO STEP 7.

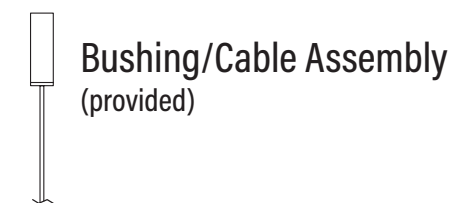
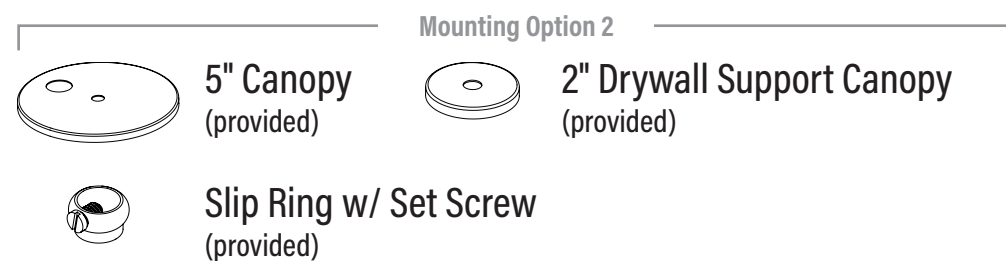
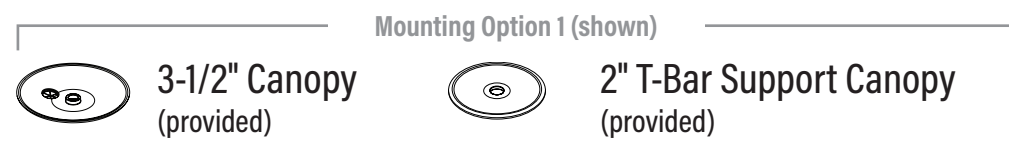

0-10V Dimming

HP-3 Indirect/Direct with Mitered Corners Installation Instructions

Step 4 - Joining Luminaires

A. Mount Joiner to Structure



CAUTION

DO NOT attempt to join luminaires together on the floor. Damage may result when lifted. Follow these instructions.

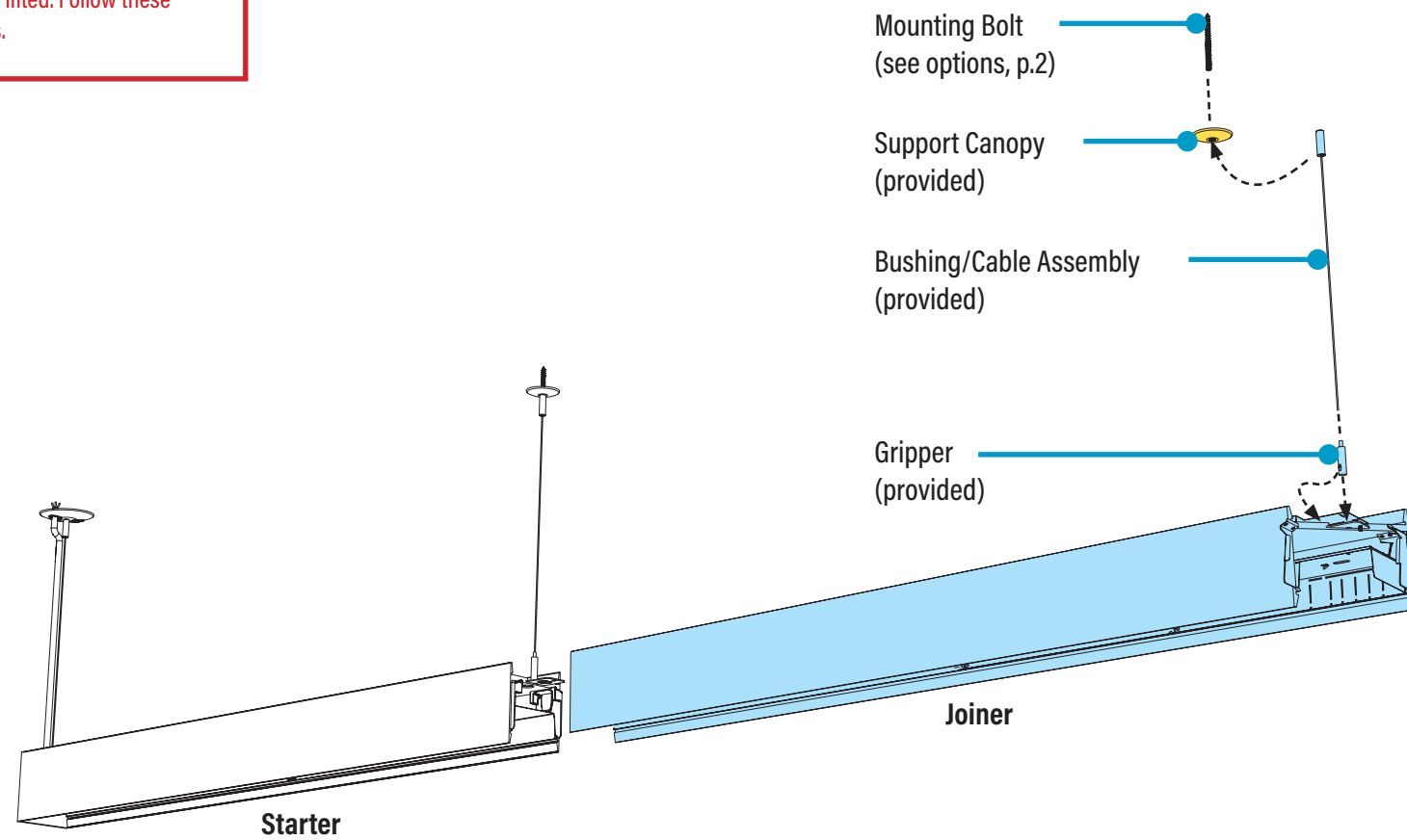

- For the joiner luminaire, slide canopy appropriate for electrical type onto mounting bolt (anchor bolt or caddy clip bolt).
- Thread the bushing/cable assembly onto mounting bolt.
- Attach grippers onto threaded studs found on end plates of joiner luminaire.
- While properly supporting luminaire, maneuver luminaire to ceiling.
- Depress the top of the gripper to feed the aircraft cable through and lead into the feed hole.

B. Make Electrical Connections

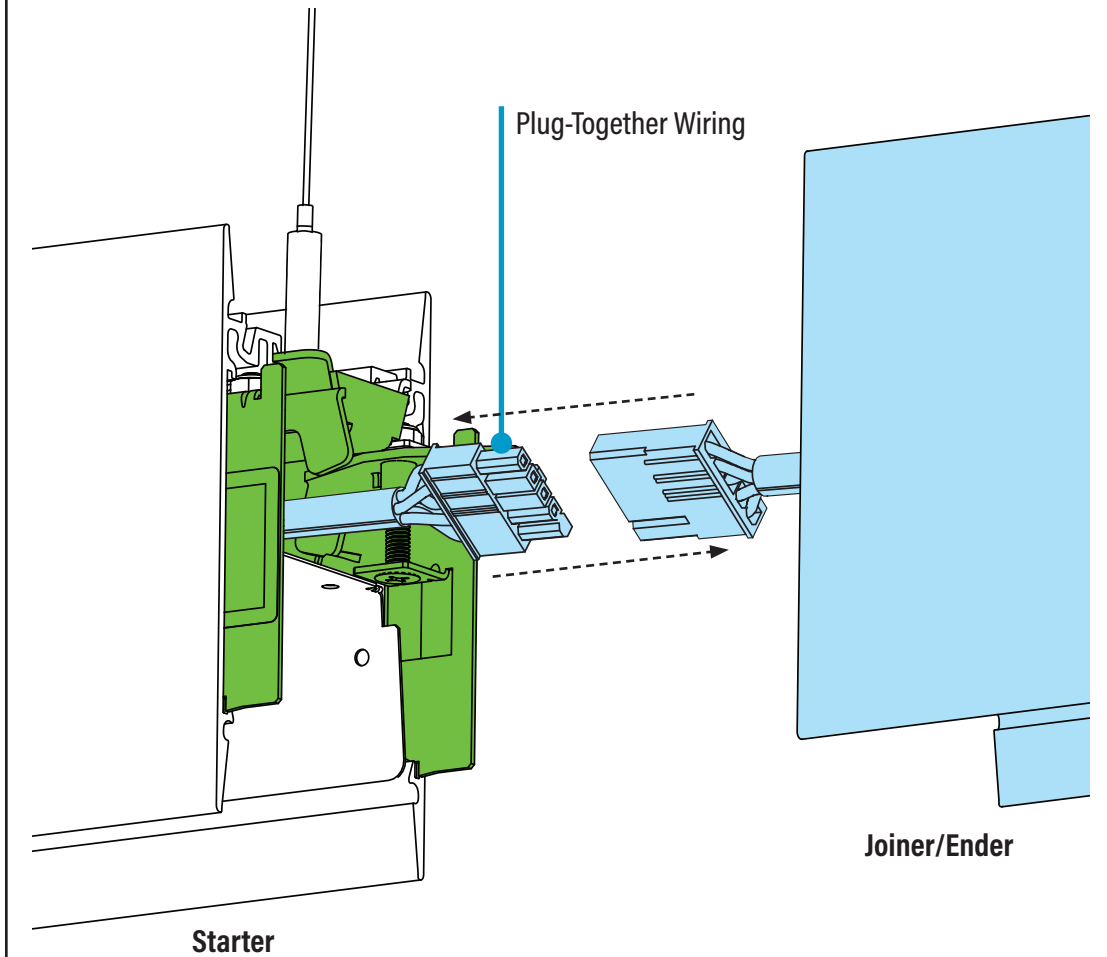

- Connect plug-together wiring.

Mounting Option 1 (shown)



3-1/2" Canopy
(provided)

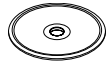

2" T-Bar Support Canopy
(provided)

Mounting Option 2

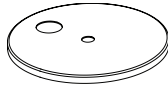

5" Canopy
(provided)

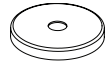

2" Drywall Support Canopy
(provided)



Slip Ring w/ Set Screw
(provided)



Bushing/Cable Assembly
(provided)



Gripper
(provided)



Simple
Plug-Together
Wiring

HP-3 Indirect/Direct with Mitered Corners Installation Instructions

Step 5 - Securing Luminaire Joints

A. Join Luminaires



CAUTION

Once luminaires are aligned together, **joiner luminaire is not yet secure**. Ensure it does not slide off as it rests on the starter luminaire.

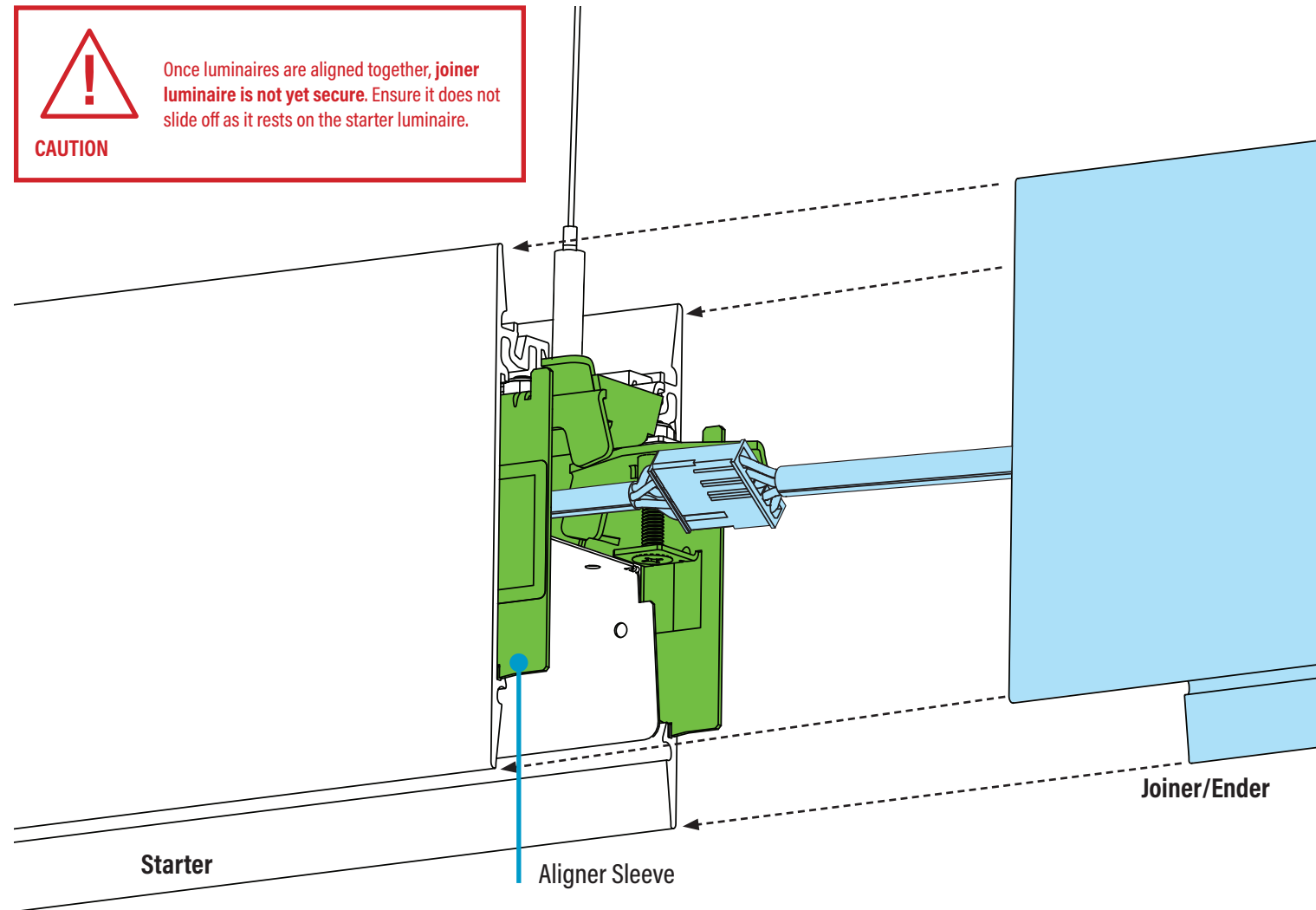

- Align joiner/ender luminaire with aligner sleeves on the starter and slide together. Be careful not to damage any wiring.
- If necessary, lift both luminaires, then slide together.

B. Secure Easy Joint

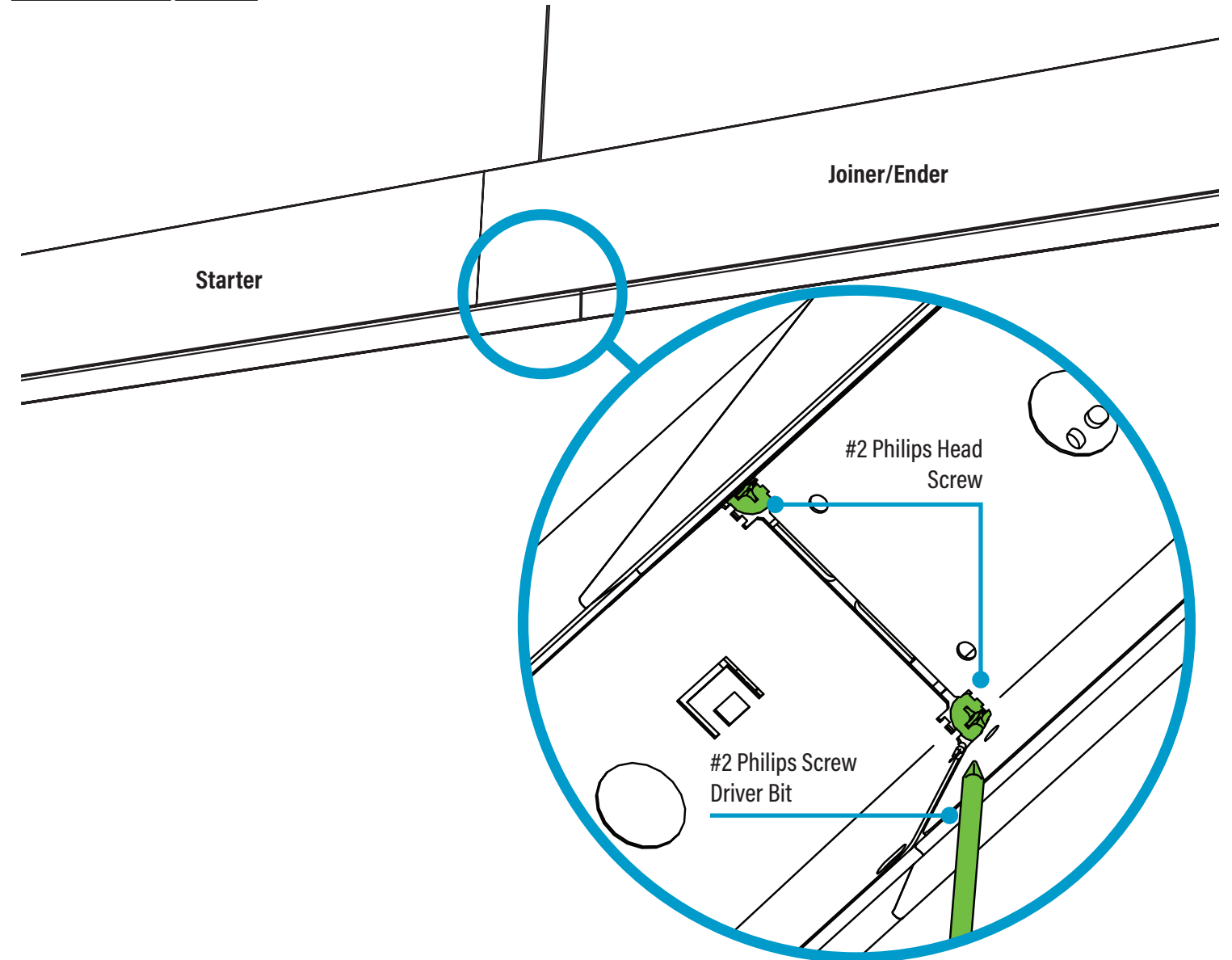

- Secure Joiner/Ender with Starter by tightening two #2 Philips Head Screws.
- Tighten two screws simultaneously and apply equal pressure to each one until tightened.
- **DO NOT USE impact drivers. Only use drivers with torque limit setting and set to low to prevent stripping the screw.**
- **DO NOT OVER TORQUE. DO NOT EXCEED 20 in-lb TORQUE**

HP-3 Indirect/Direct with Mitered Corners Installation Instructions

Step 6 - Joining Mitered Corners

A. Mount Ender to Structure

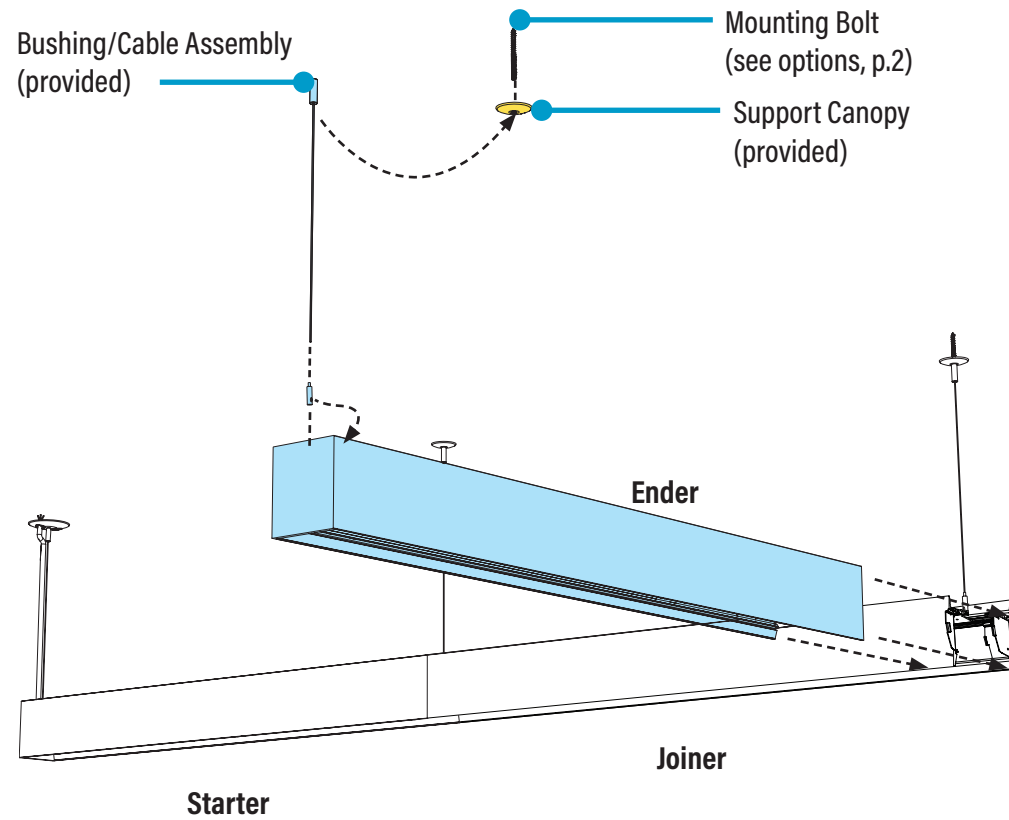

- For the ender luminaire, slide canopy onto mounting bolt (anchor bolt or caddy clip bolt).
- Thread the bushing/cable assembly onto mounting bolt.
- Attach grippers onto threaded studs found on end plates of joiner luminaire.
- While properly supporting luminaire, maneuver luminaire to ceiling.
- Depress the top of the gripper to feed the aircraft cable through and lead into the feed hole.

B. Join Mitered Corners

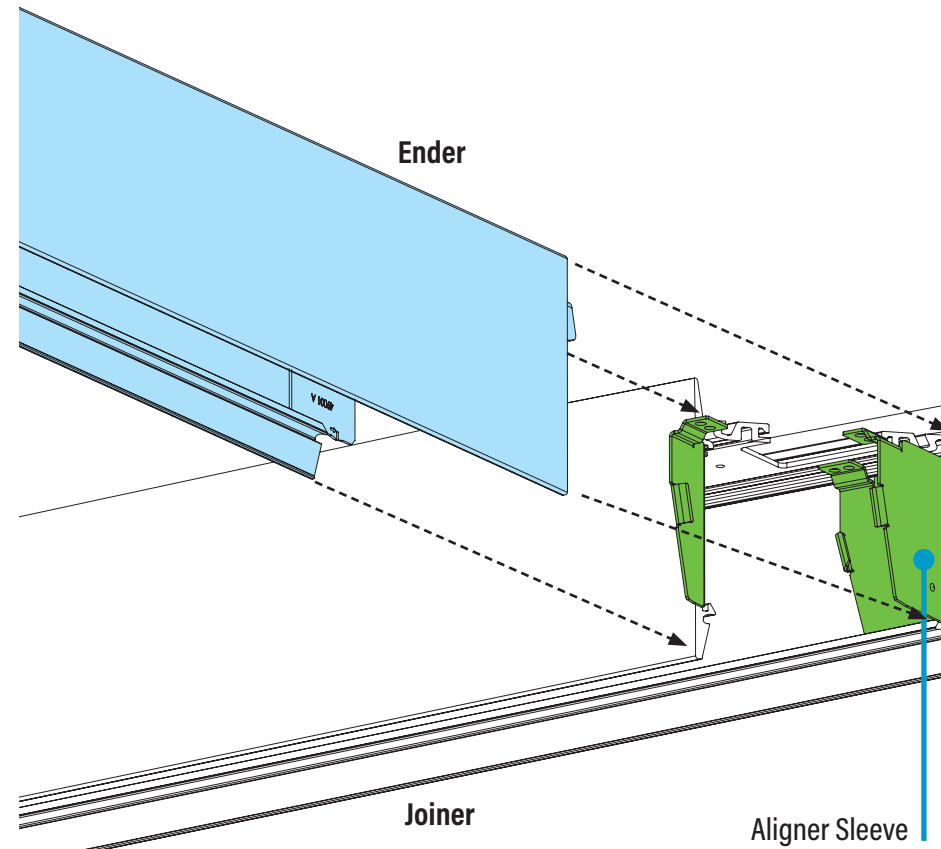

- Align ender luminaire with aligner sleeves on joiner and slide together. Be careful not to damage any wiring.
- If necessary, **lift** both luminaires, then slide together.

C. Secure Easy Joint

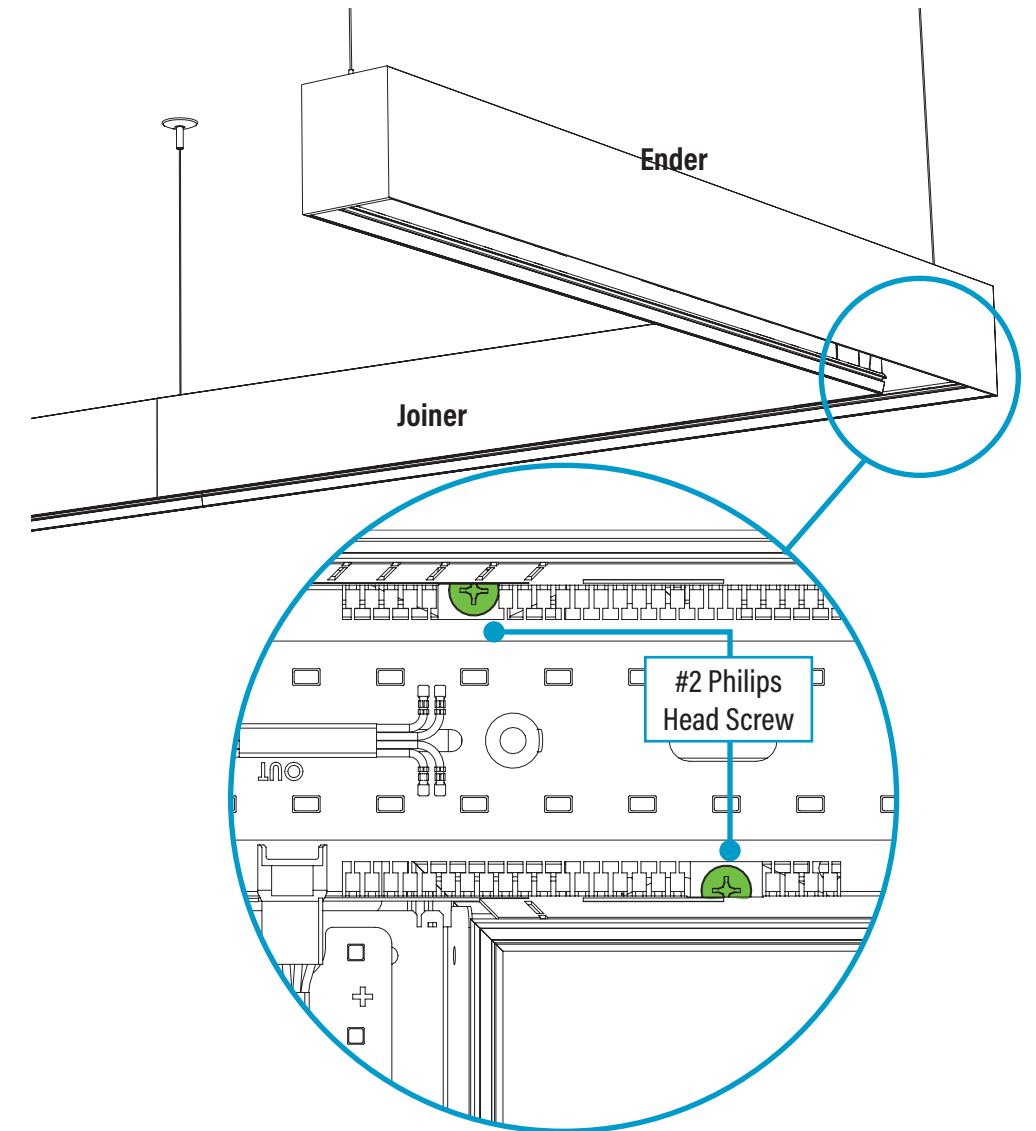

- Secure Mitered Corner by tightening two #2 Philips Head Screws.
- Tighten two screws simultaneously and apply equal pressure to each one until tightened.
- **DO NOT USE impact drivers. Only use drivers with torque limit setting and set to low to prevent stripping the screw.**
- **DO NOT OVER TORQUE. DO NOT EXCEED 20 in-lb TORQUE**

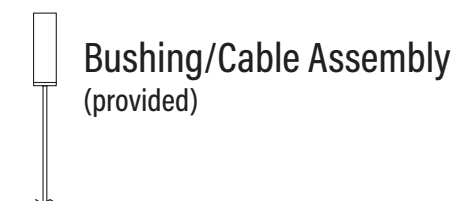
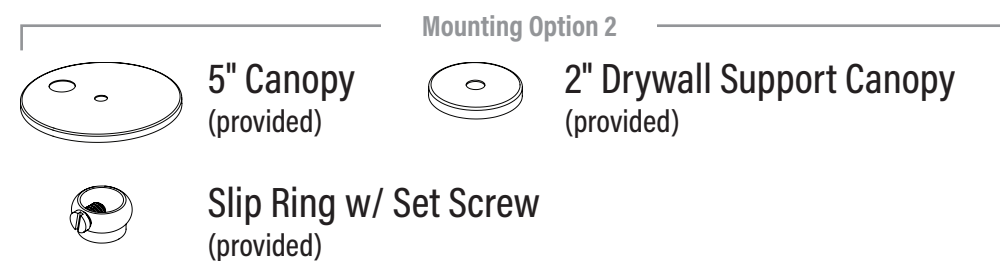
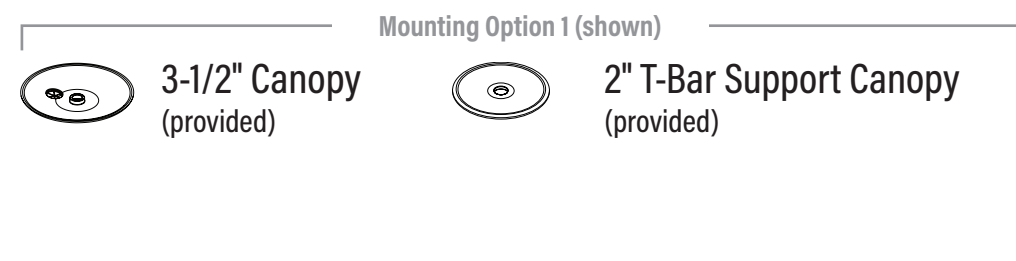

HP-3 Indirect/Direct with Mitered Corners Installation Instructions

Step 7 - Closing Luminaires

A. Final Step - Replace Backplates & Diffusers

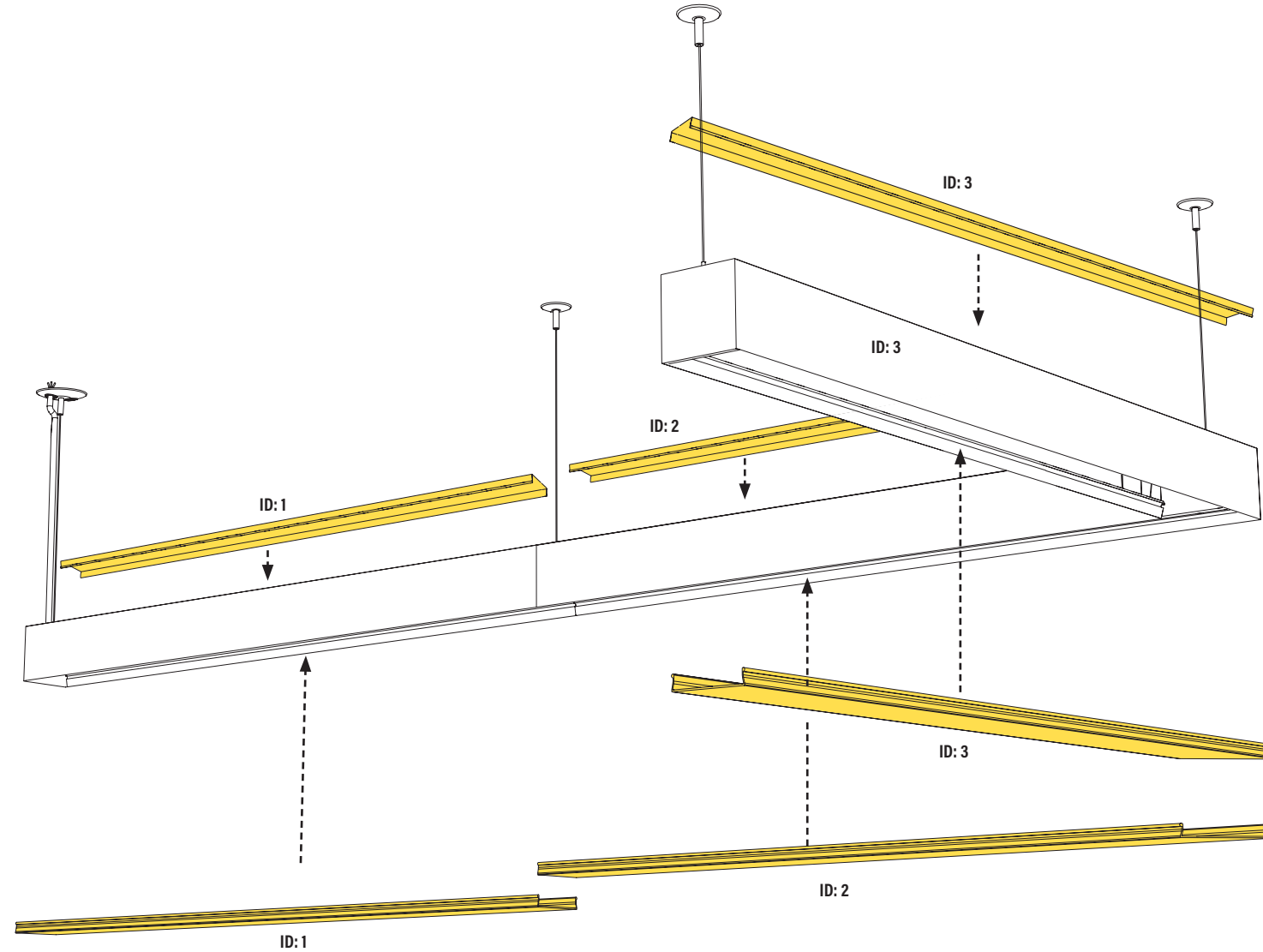

- **NOTE:** If your installation includes a battery backup, please see addendum (98333) that should be included with your kitting package.
- **FOR SENSOR:** If luminaire contains a sensor at joint, refer to page 5 of Sensor Addendum before Closing Luminaires.
- Remove diffusers from protective plastic bags.
- **CAUTION:** Wear gloves to keep diffuser or louver surface clean.
- **CRITICAL:** Be sure to install correct diffuser or louver to its corresponding luminaire ID.
- Install diffuser into luminaire body, ensuring it snaps into place.
- Turn power on to luminaires.