

# HP-3 Direct with Mitered Corners Installation Instructions

## Overview

### NOTES

- If luminaire contains a sensor refer to the Sensor Addendum.
- All power connections should be installed according to local/national codes by a Certified Electrician.
- This installation requires **proper support** as each luminaire is being installed.
- **DO NOT attempt to join luminaires together on the floor.** Damage may result when lifted.



HELPFUL  
VIDEOS



0-10V  
Dimming



Effortless  
Access



Simple  
Plug-Together  
Wiring

**Step 1**  
Mounting & Suspension  
Page 2

**Step 2**  
Identification & Preparation  
Page 3

**Step 3**  
Mounting Starter to Structure  
Page 4

**Step 4**  
Joining Luminaires  
Page 5

**Step 5**  
Securing Luminaire Joints  
Page 6

**Step 7**  
Closing Luminaires  
Page 8

**Step 6**  
Joining Mitered Corner  
Page 7

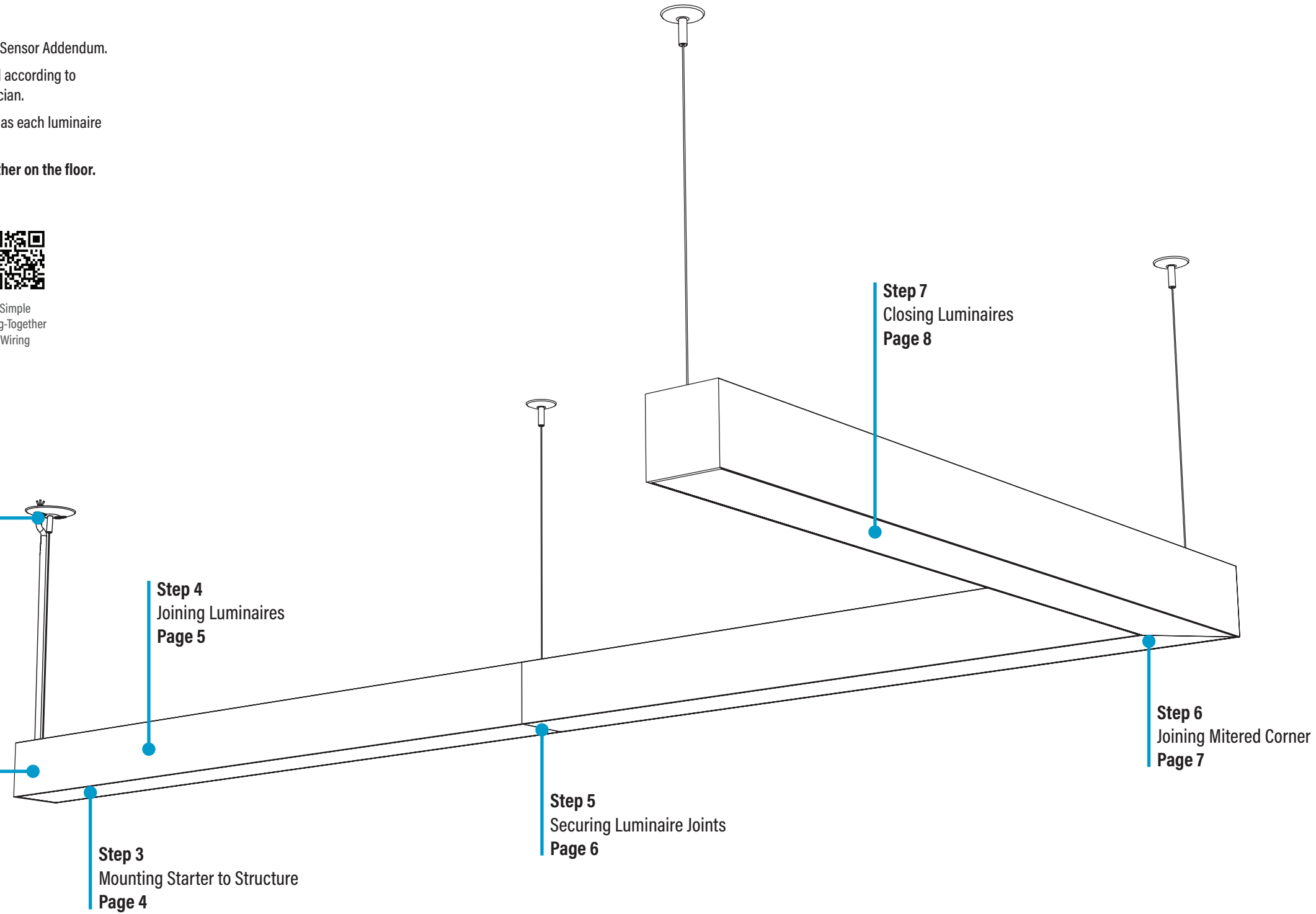

# HP-3 Direct with Mitered Corners Installation Instructions

## Step 1 - Mounting & Suspension

### Mounting Options

#### Option 1 T-Bar Mounting - GridBox™ and Caddy Clips

- Install GridBox™ and electrical conduit at feed locations.
- Install caddy clips at mounting point locations.
- All caddy clips are to be secured to structure, per local building codes.

#### Option 2 Drywall (C4) or other hard surfaces\* - J-Box and Anchor Bolts

- Install J-Box and electrical conduit at feed locations.
- Install anchor bolts at mounting point locations.
- All anchor bolts are to be secured to structure, per local building codes.

\*Other hard surfaces include: wood, sheet metal panels, steel beams, concrete or masonry. Use hardware appropriate for each surface material type.

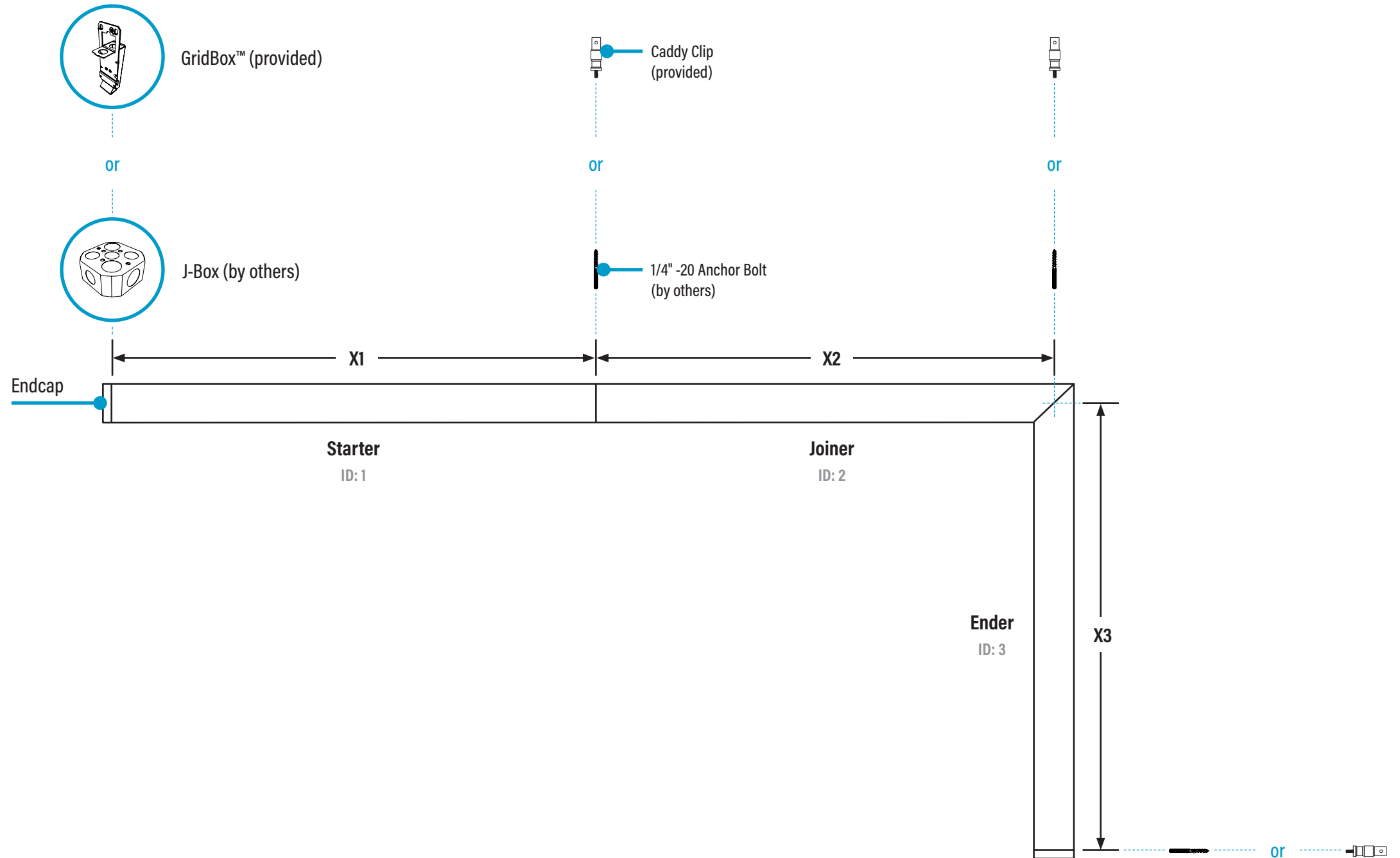

### Suspension Locations

X = Suspension Dimensions

Refer to Record Drawings and building plans to determine exact mounting, suspension points, and power feed locations.

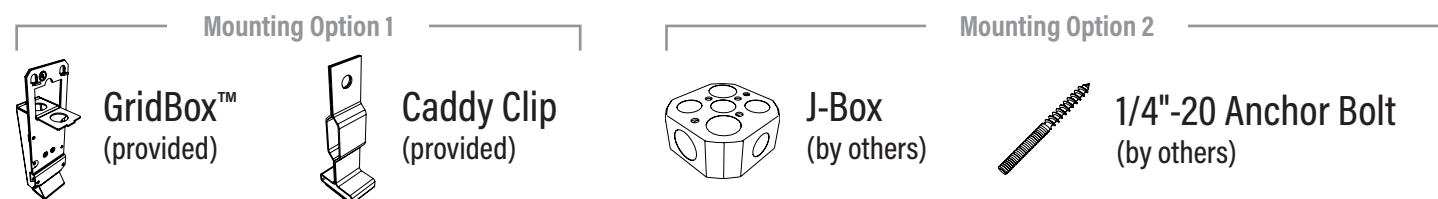

# HP-3 Direct with Mitered Corners Installation Instructions

## Step 2 - Identification & Preparation

### A. Identify Luminaires



Arrange luminaires in order according to ID# at their install locations.

**CAUTION**

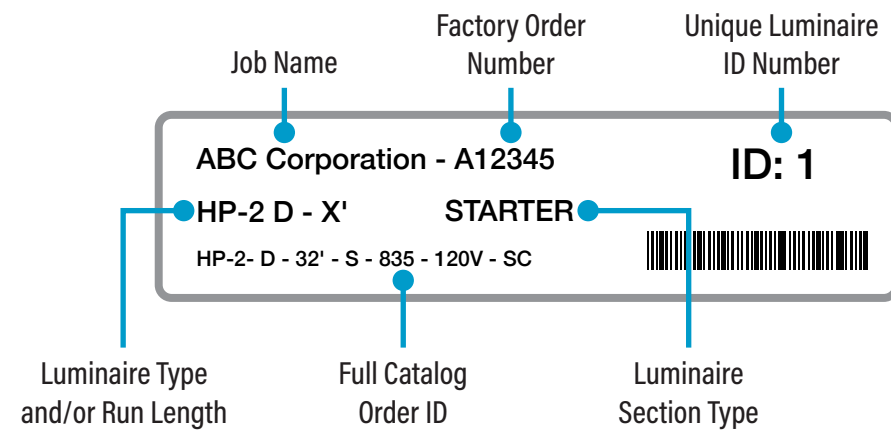

- Identify all luminaires by their ID label that can be found on the box, the diffuser, and inside the luminaire.
- **NOTE:** Exact location of labels in these areas may vary.
- Remove all luminaires from their box.
- Refer to Record Drawings that can be found in the hardware kit.



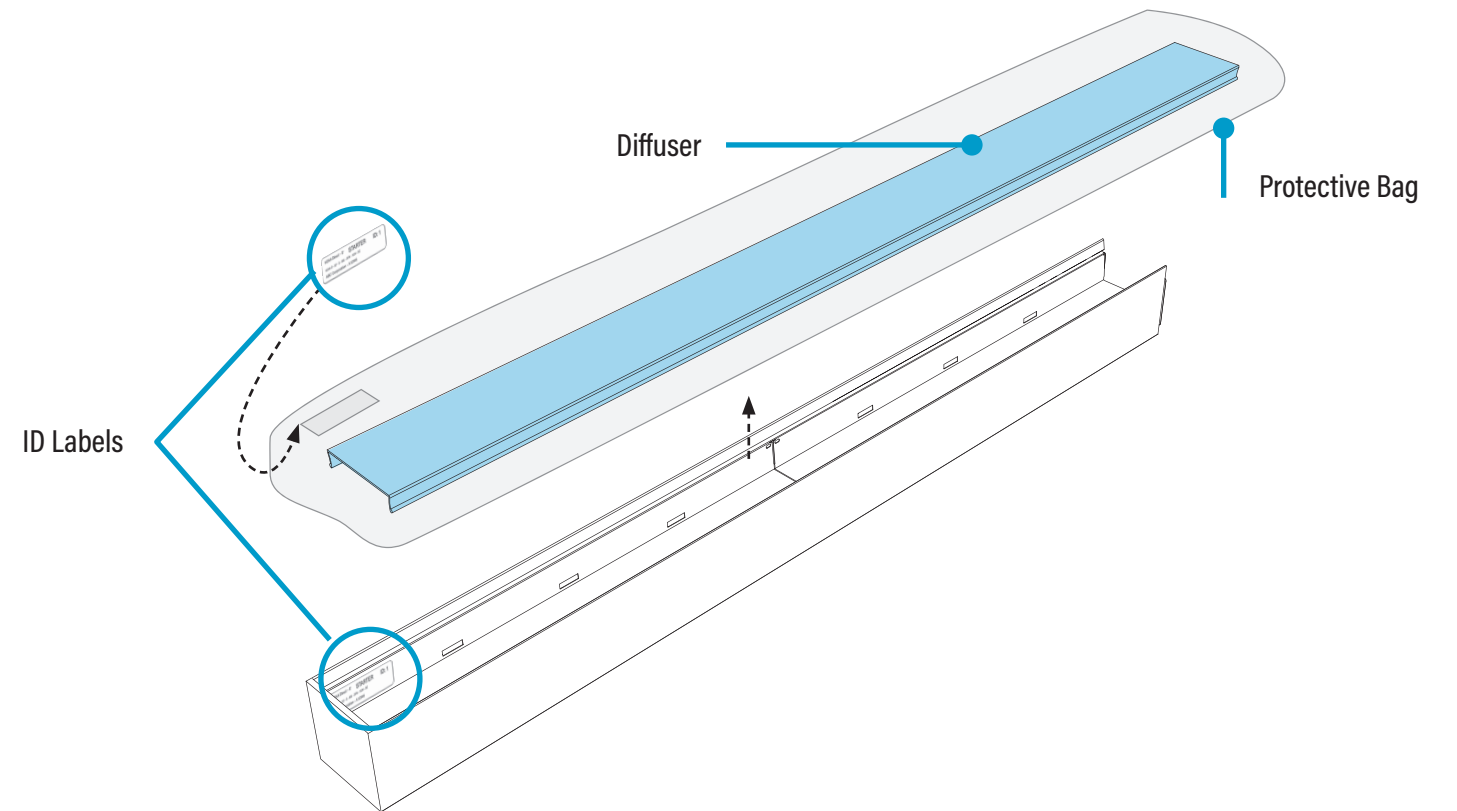





### B. Remove Diffusers

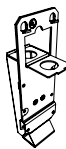

- Carefully remove all diffusers, keeping them inside their protective bags.
- Set aside all diffusers to prevent from getting dirty or damaged.
- Ensure diffusers can be clearly identified back to their corresponding luminaire.

### Kitted Hardware

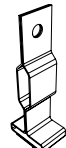
- Finelite has provided items listed here, with their Finelite part numbers. These items can be found in separate boxes shipped with the luminaire.
- Account for all parts and set aside until they are needed.
- All other hardware needed for this installation will be by others.

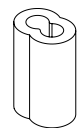
Mounting Option 1		Mounting Option 2									
	<b>GridBox™</b> Part# 89159		<b>3-1/2" Canopy</b> Part# 89191		<b>5" Canopy</b> Part# 94085		<b>Cable Bushing</b> Part# 94014		<b>Gripper</b> Part# 68129		<b>Slip Ring w/ Set Screw</b> Part# 94015
	<b>Dual GridBox™</b> Part# 89199 Mounting & Suspension p. 2, Step 1		<b>3-1/2" Dual Feed Canopy</b> Part# 89192 Mounting Starter to Structure p. 4, Step 3 Joining Luminaires p. 5, Step 4 Joining Mitered Corners p. 8, Step 7		<b>5" Dual Feed Canopy</b> Part# 94145 Mounting Starter to Structure p. 4, Step 3 Joining Luminaires p. 5, Step 4 Joining Mitered Corners p. 8, Step 7		<b>Aircraft Cable</b> 50" - Part# 94515-12 (Std.) 100" - Part# 94515-14 150" - Part# 94515-18 Mounting Starter to Structure p. 4, Step 3 Joining Luminaires p. 5, Step 4 Joining Mitered Corners p. 8, Step 7		Mounting Starter to Structure p. 4, Step 3 Joining Luminaires p. 5, Step 4 Joining Mitered Corners p. 8, Step 7		Mounting Starter to Structure p. 4, Step 3 Joining Luminaires p. 5, Step 4 Joining Mitered Corners p. 8, Step 7
	<b>Caddy Clip</b> C1 Ceiling - Part# 94001 C2 Ceiling - Part# 94020 C3 Ceiling - Part# 94029 Mounting & Suspension p. 2, Step 1		<b>2" T-Bar Support Canopy</b> Part# 89193 Mounting Starter to Structure p. 4, Step 3 Joining Luminaires p. 5, Step 4 Joining Mitered Corners p. 8, Step 7		<b>2" Drywall Support Canopy</b> Part# 94017 Mounting Starter to Structure p. 4, Step 3 Joining Luminaires p. 5, Step 4 Joining Mitered Corners p. 8, Step 7		<b>Safety Crimp</b> Part# 94514 Closing Luminaires p. 10, Step 9				

# HP-3 Direct with Mitered Corners Installation Instructions

## Step 3 - Mounting Starter to Structure

### A. Mount Starter to Structure

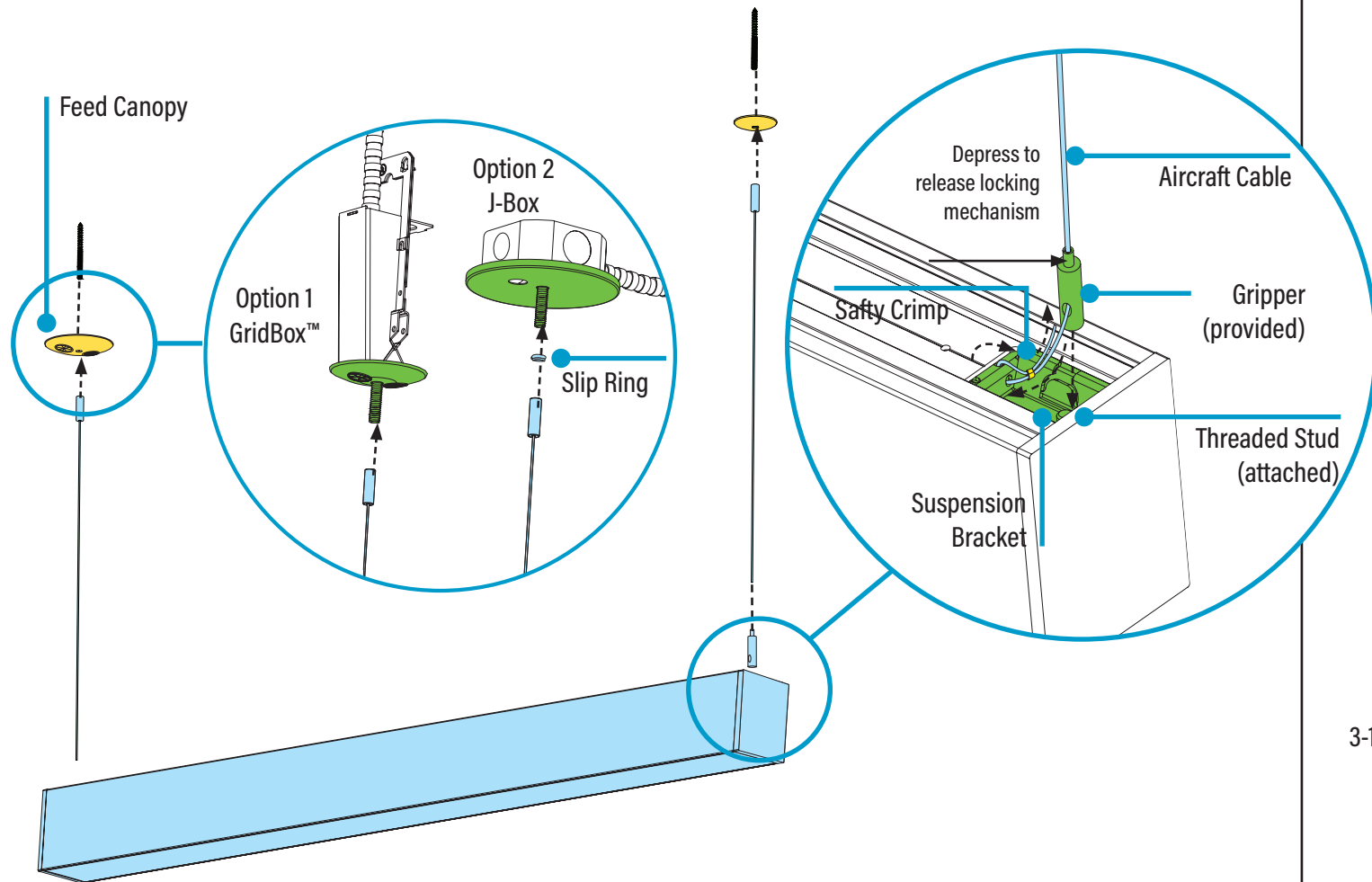

- Slide canopy appropriate for electrical type options onto mounting bolt (anchor bolt or caddy clip bolt).
- (Option 2 only) Thread the Slip Ring onto anchor bolts and secure it with a set screw at both mounting locations.
- Thread the bushing/cable assembly onto mounting bolts.
- Attach grippers onto threaded studs found on the end plates of the starter luminaire.
- While properly supporting the luminaire, maneuver the luminaire to the ceiling.
- Depress the top of the gripper to feed the Aircraft Cable through and lead into the feed hole.
- Loop cable through Safety Crimp and holes in Suspension Bracket, then back through Safety Crimp.
- Crimp, then cut the excess cable.

### B. Make Electrical Connections

WIRING LEGEND		
Black	Hot	Line Voltage
White	Neutral	Line Voltage
Green	Ground	
Pink	Dimming	0-10V DC
Purple	Dimming	0-10V DC

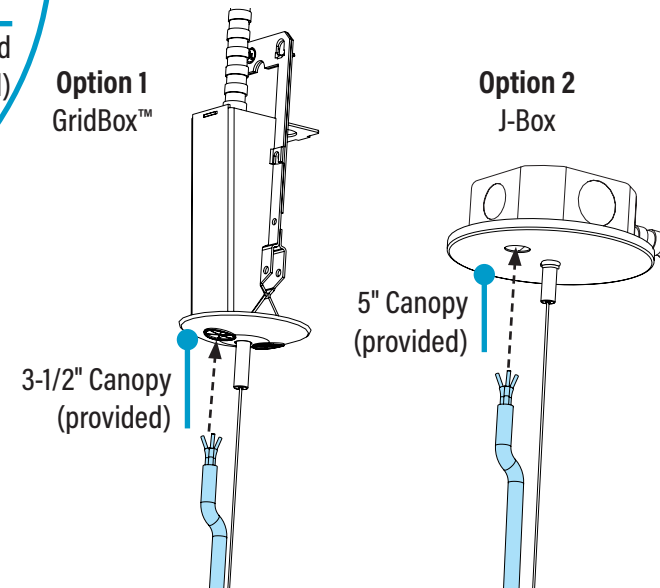

- (Option 1) Feed power cord through the 3-1/2" canopy and connect wires inside the GridBox™.
- (Option 2) Feed power cord through the 5" canopy and connect wires inside the J-Box.
- **CRITICAL:** If installing an independent luminaire, perform all leveling. **PROCEED TO STEP 5.**

### OPTIONAL

Flexible Mount pendant brackets are adjustable for custom mounting locations.

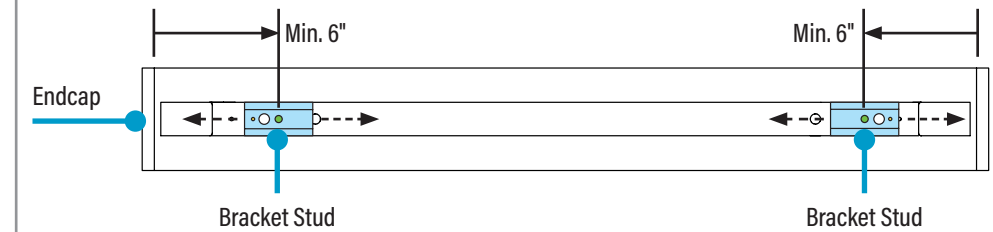

- **NOTE:** Minimum 6" from end of housing to bracket stud on pendant bracket.
- Maximum distance depends on length of luminaire (see table).

Luminaire Length	Max.
4' - 12'	24"
3' and less	12"

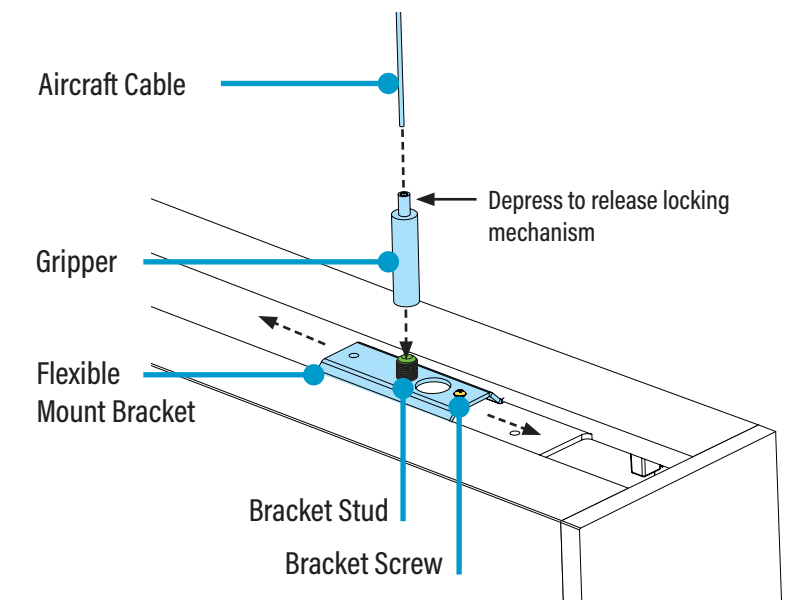

- Loosen (**but do not remove**) the bracket screw.
- Slide flexible mount pendant bracket to desired location and tighten screw to secure.
- Attach gripper onto bracket stud.
- Feed bushing/cable assembly through gripper by depressing top of gripper.
- Allow excess cable to rest atop luminaire. Crimp then trim, if necessary.

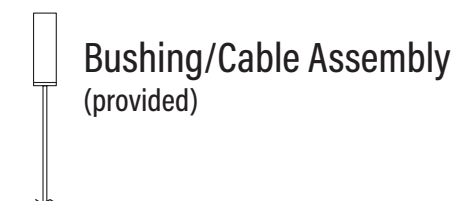
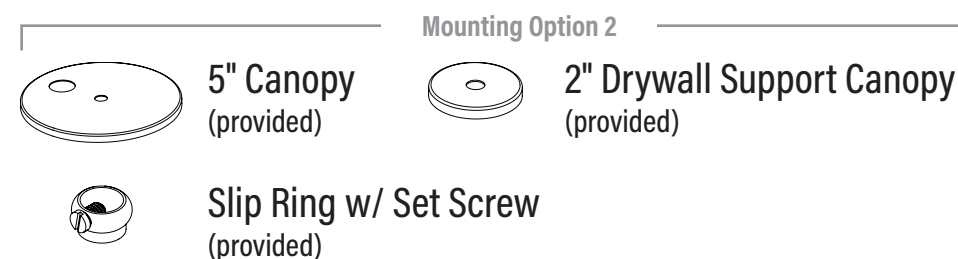

0-10V Dimming

# HP-3 Direct with Mitered Corners Installation Instructions

## Step 4 - Joining Luminaires

### A. Mount Joiner to Structure



**CAUTION**

**DO NOT** attempt to join luminaires together on the floor. Damage may result when lifted. Follow these instructions.

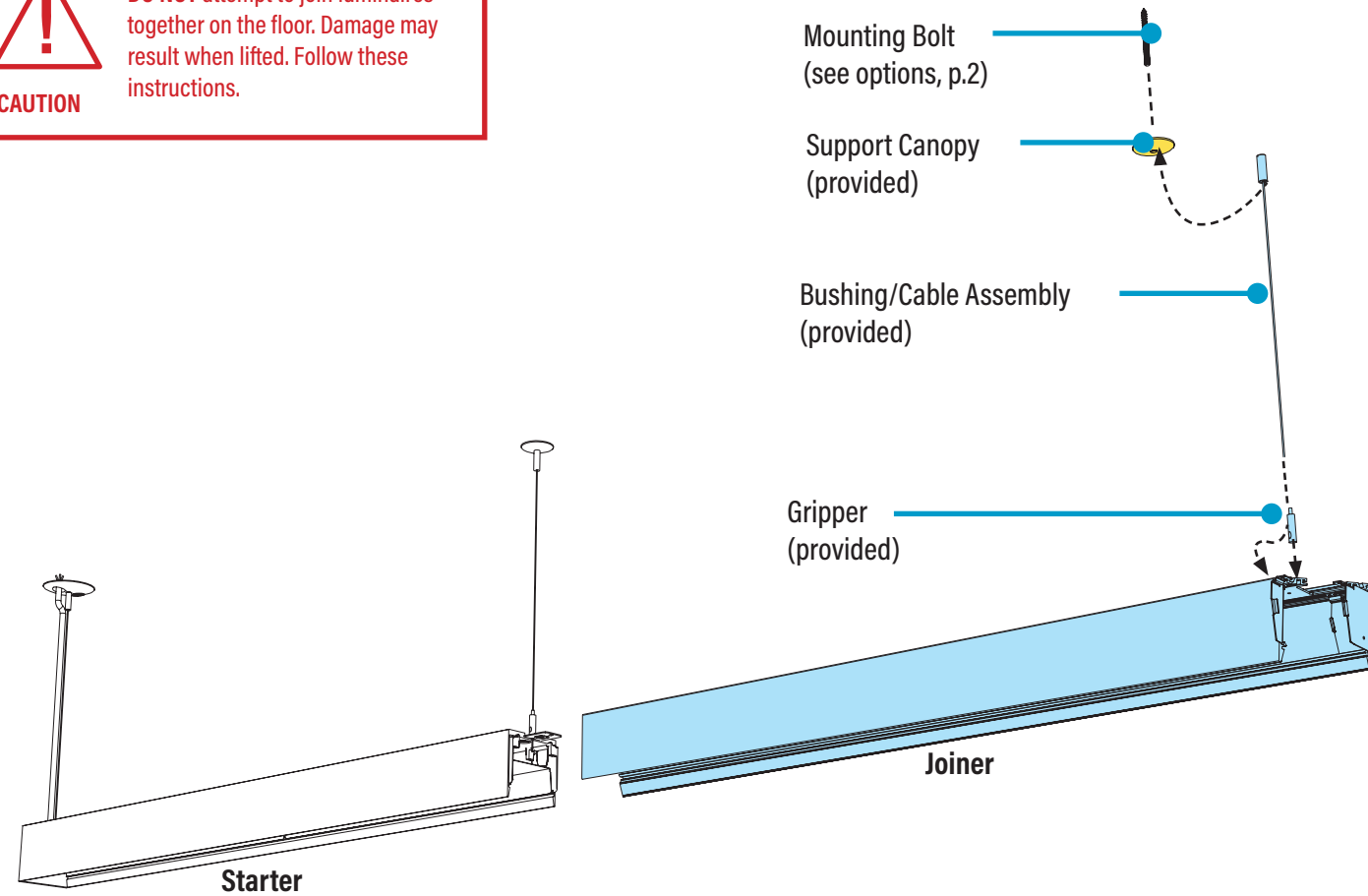

### B. Make Electrical Connections

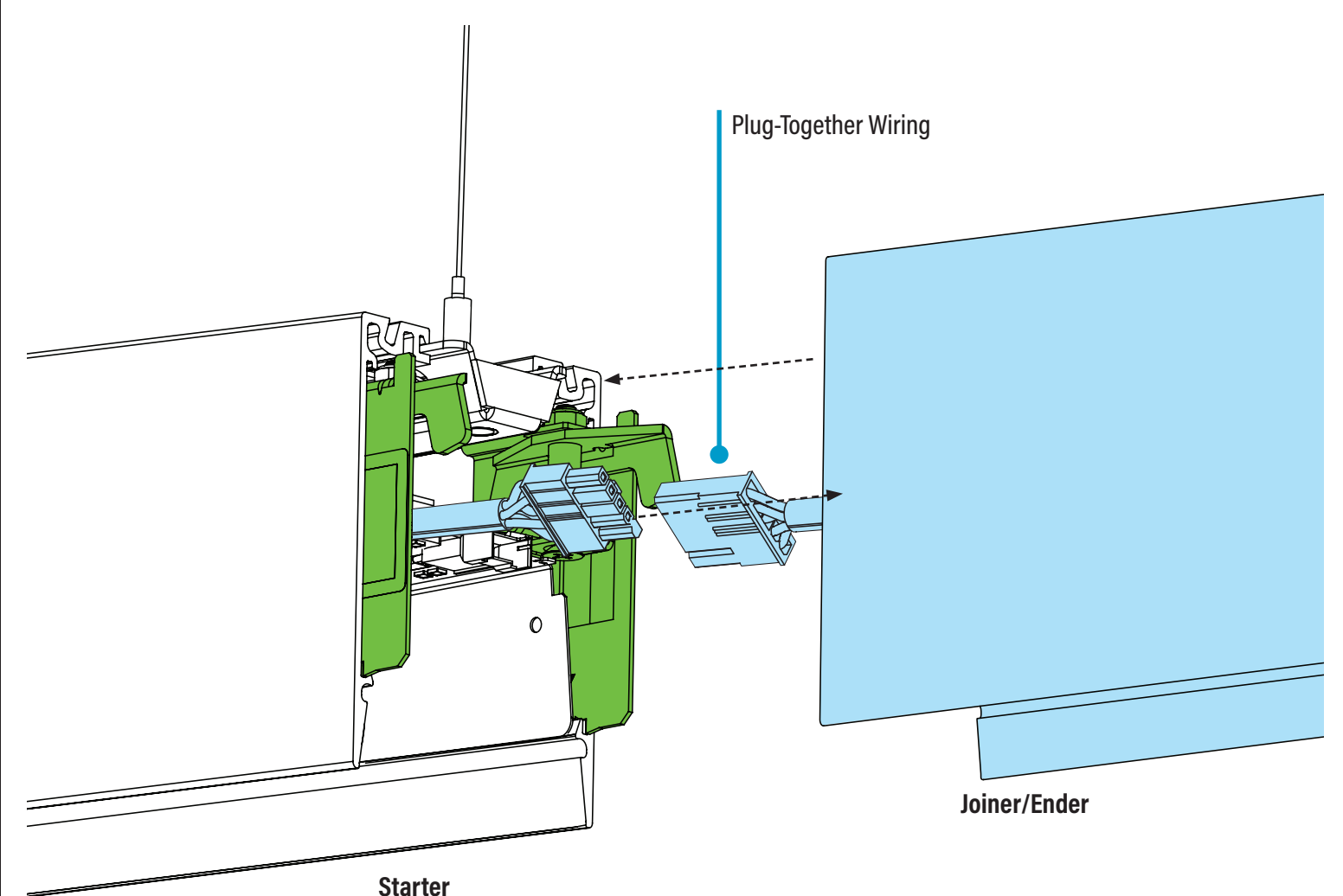

- For the joiner luminaire, slide canopy appropriate for electrical type onto mounting bolt (anchor bolt or caddy clip bolt).
- Thread the bushing/cable assembly onto mounting bolt.
- Attach grippers onto threaded studs found on end plates of joiner luminaire.
- While properly supporting luminaire, maneuver luminaire to ceiling.
- Depress the top of the gripper to feed the aircraft cable through and lead into the feed hole.

- Connect plug-together wiring.

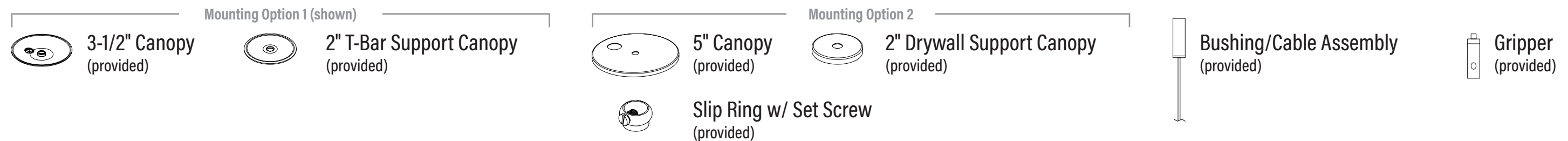

# HP-3 Direct with Mitered Corners Installation Instructions

## Step 5 - Securing Luminaire Joints

### A. Join Luminaires



Once luminaires are aligned together, **joiner luminaire is not yet secure**. Ensure it does not slide off as it rests on the starter luminaire.

**CAUTION**

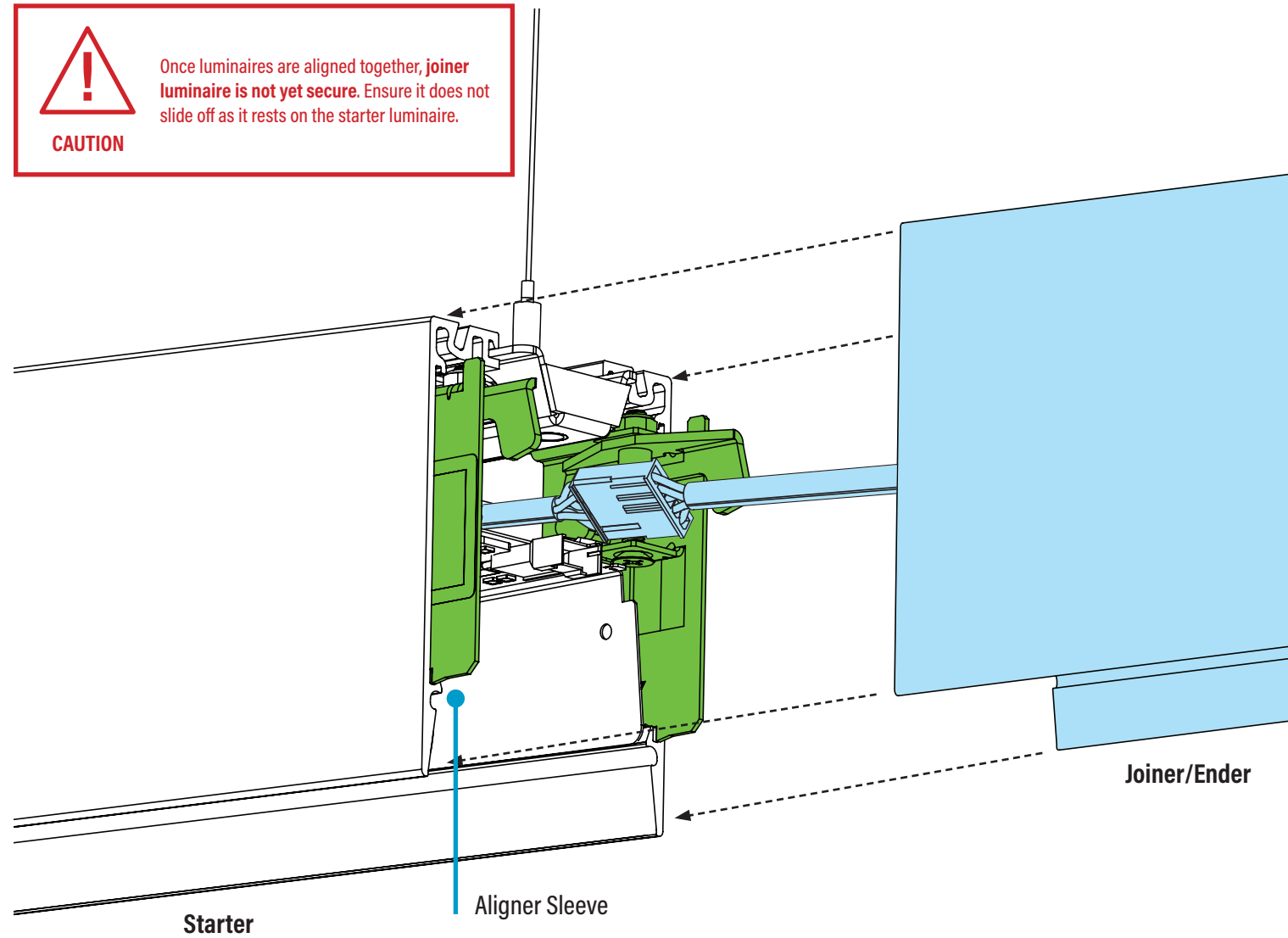

- Align joiner/ender luminaire with aligner sleeves on the starter and slide together. Be careful not to damage any wiring.
- If necessary, lift both luminaires, then slide together.

### B. Secure Easy Joint

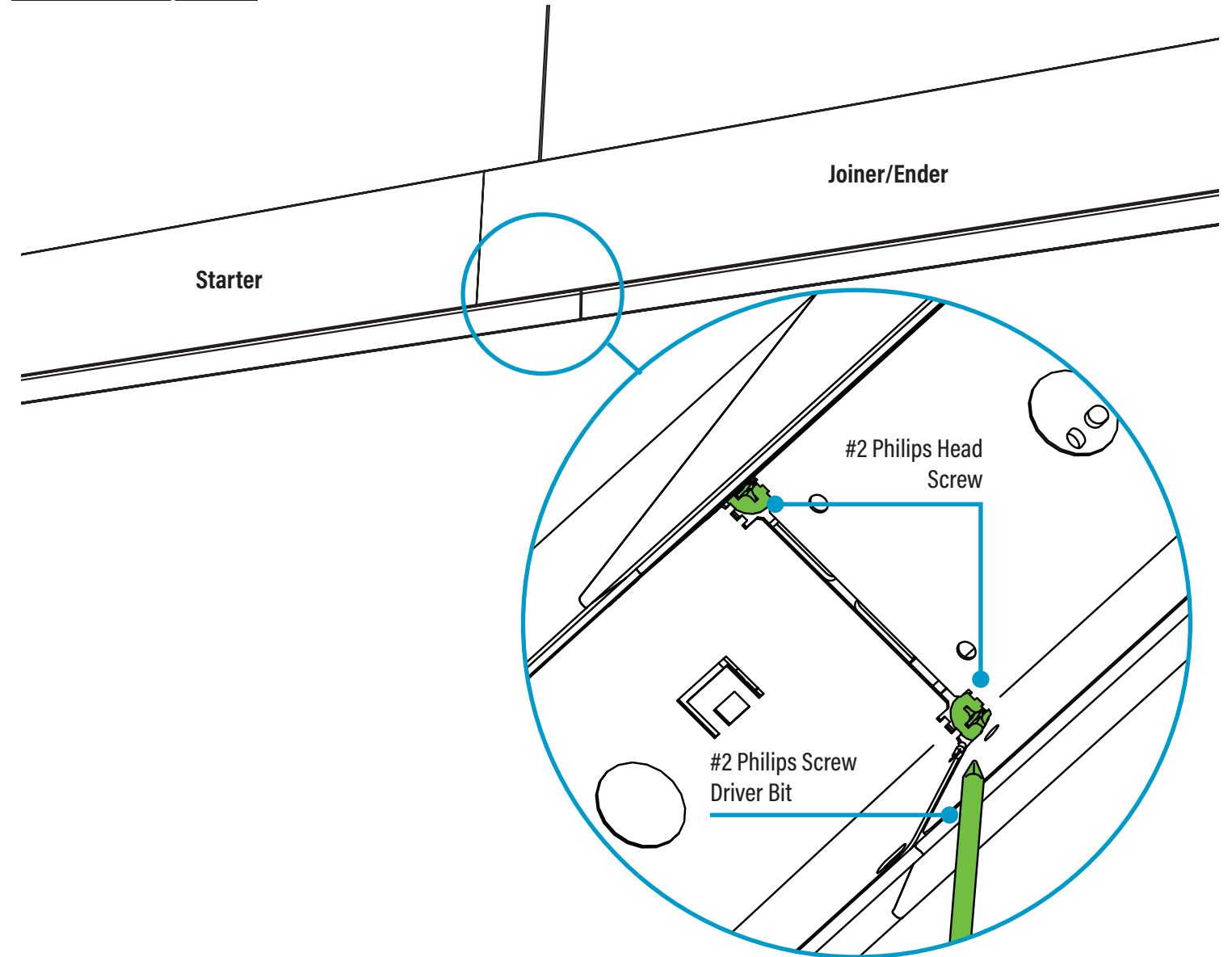

- Secure Joiner/Ender with Starter by tightening two #2 Philips Head Screws.
- Tighten two screws simultaneously and apply equal pressure to each one until tightened.
- **DO NOT USE impact drivers. Only use drivers with torque limit setting and set to low to prevent stripping the screw.**
- **DO NOT OVER TORQUE. DO NOT EXCEED 20 in-lb TORQUE**

# HP-3 Direct with Mitered Corners Installation Instructions

## Step 6 - Joining Mitered Corners

### A. Mount Ender to Structure

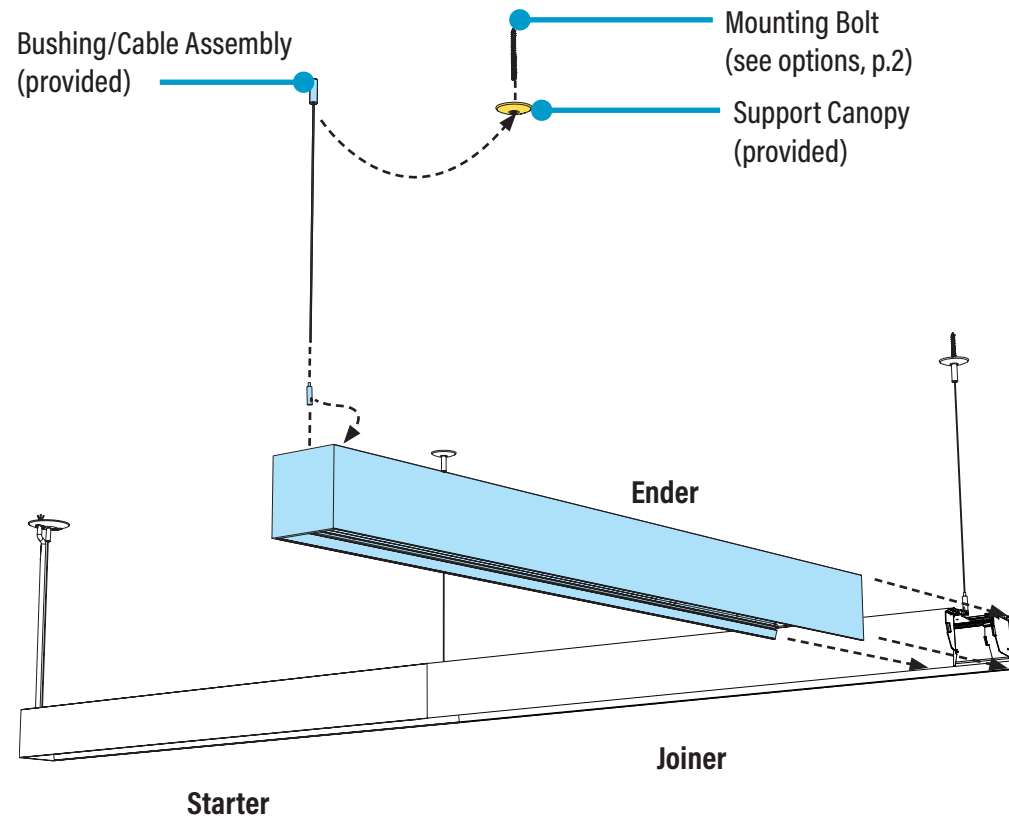

- For the ender luminaire, slide canopy onto mounting bolt (anchor bolt or caddy clip bolt).
- Thread the bushing/cable assembly onto mounting bolt.
- Attach grippers onto threaded studs found on end plates of joiner luminaire.
- While properly supporting luminaire, maneuver luminaire to ceiling.
- Depress the top of the gripper to feed the aircraft cable through and lead into the feed hole.

### B. Join Mitered Corners

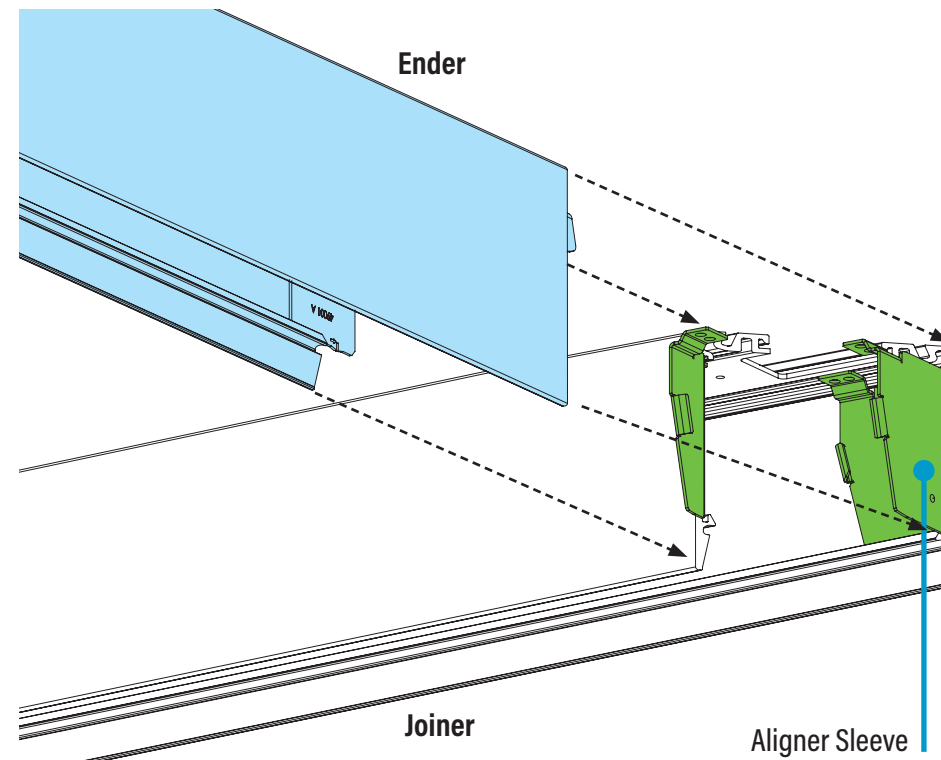

- Align ender luminaire with aligner sleeves on joiner and slide together. Be careful not to damage any wiring.
- If necessary, **lift** both luminaires, then slide together.

### C. Secure Easy Joint

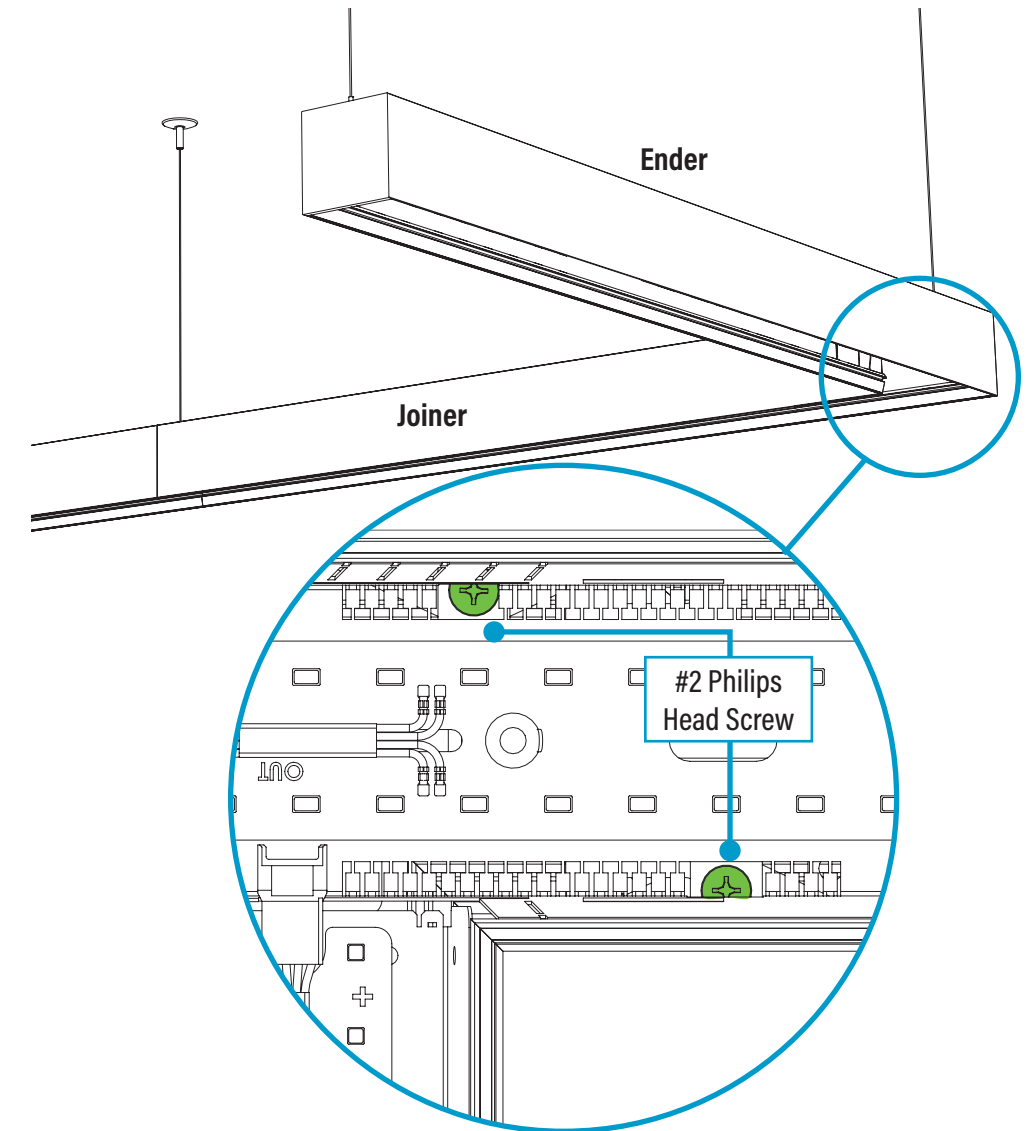

- Secure Mitered Corner by tightening two #2 Philips Head Screws.
- Tighten two screws simultaneously and apply equal pressure to each one until tightened.
- **DO NOT USE impact drivers. Only use drivers with torque limit setting and set to low to prevent stripping the screw.**
- **DO NOT OVER TORQUE. DO NOT EXCEED 20 in-lb TORQUE**

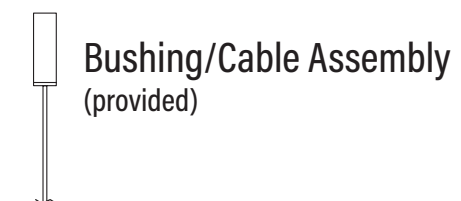
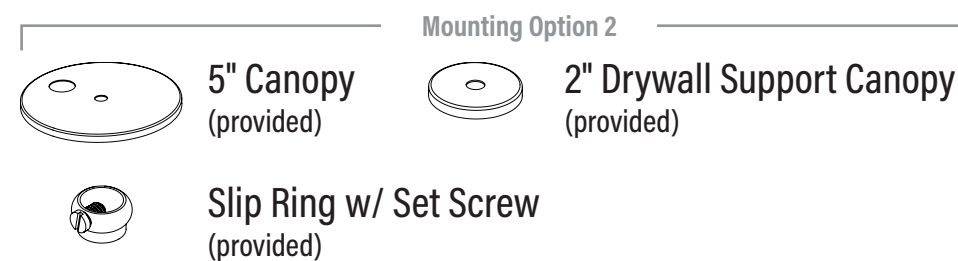

# HP-3 Direct with Mitered Corners Installation Instructions

## Step 7 - Closing Luminaires

**A. Final Step - Replace Diffusers**

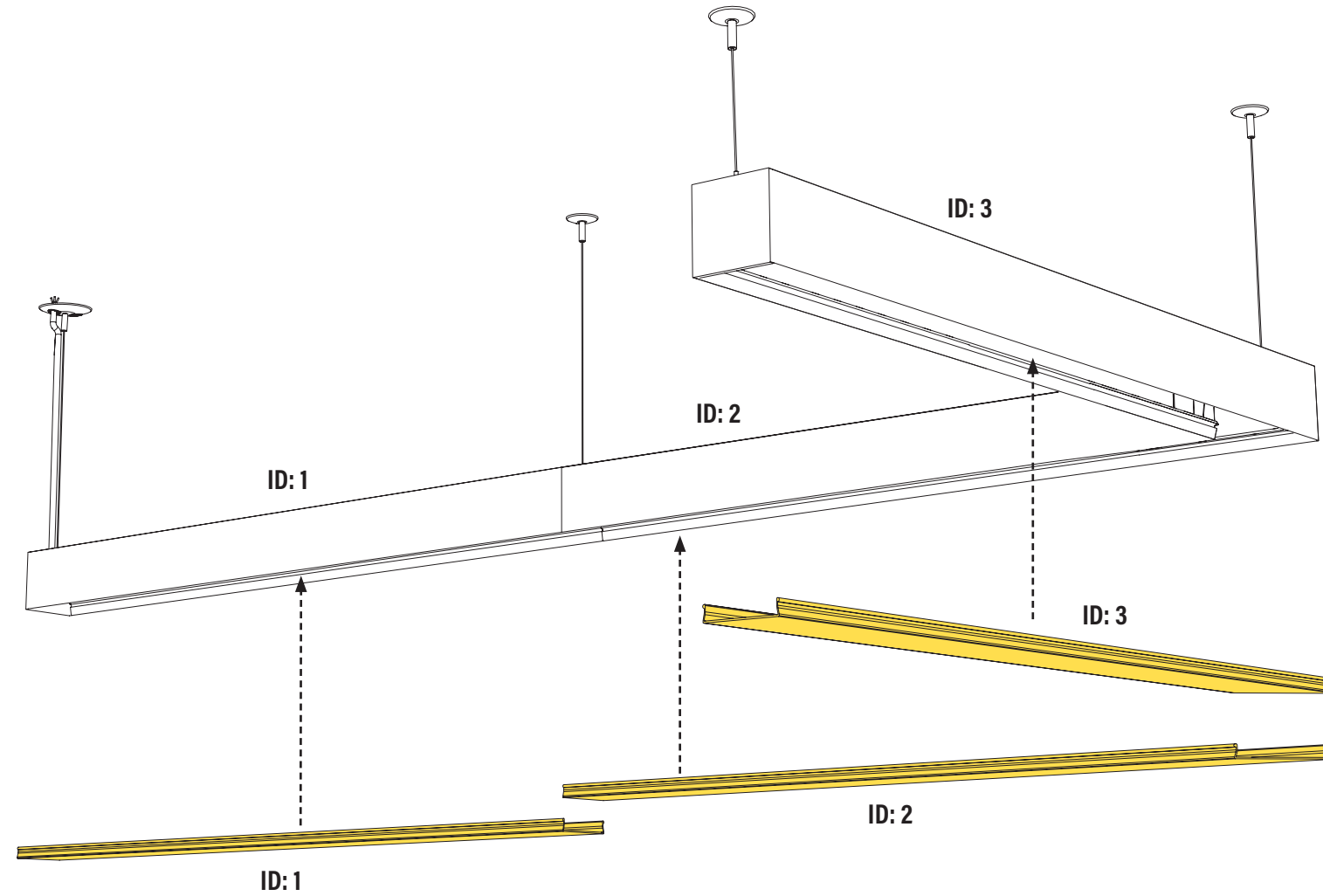

- **NOTE:** If your installation includes a battery backup, please see addendum (98333) that should be included with your kitting package.
- Remove diffusers from protective plastic bags.
- **CAUTION:** Wear gloves to keep diffuser or louver surface clean.
- **CRITICAL:** Be sure to install correct diffuser to its corresponding luminaire ID.
- Install diffuser into luminaire body, ensuring it snaps into place.
- Turn power on to luminaires.