

HP-4 Wet Location Surface Mount Installation Instructions

Overview

NOTES

- **CAUTION:** Read these instructions before proceeding.
- All power connections should be installed according to local/national codes by a Certified Electrician.
- This installation requires **proper support** as each luminaire is being installed.
- **DO NOT attempt to join luminaires together on the floor.** Damage may result when lifted.



HELPFUL
VIDEOS



Effortless
Access



0-10V
Dimming



Universal &
Robust Joints



Simple
Plug-Together
Wiring

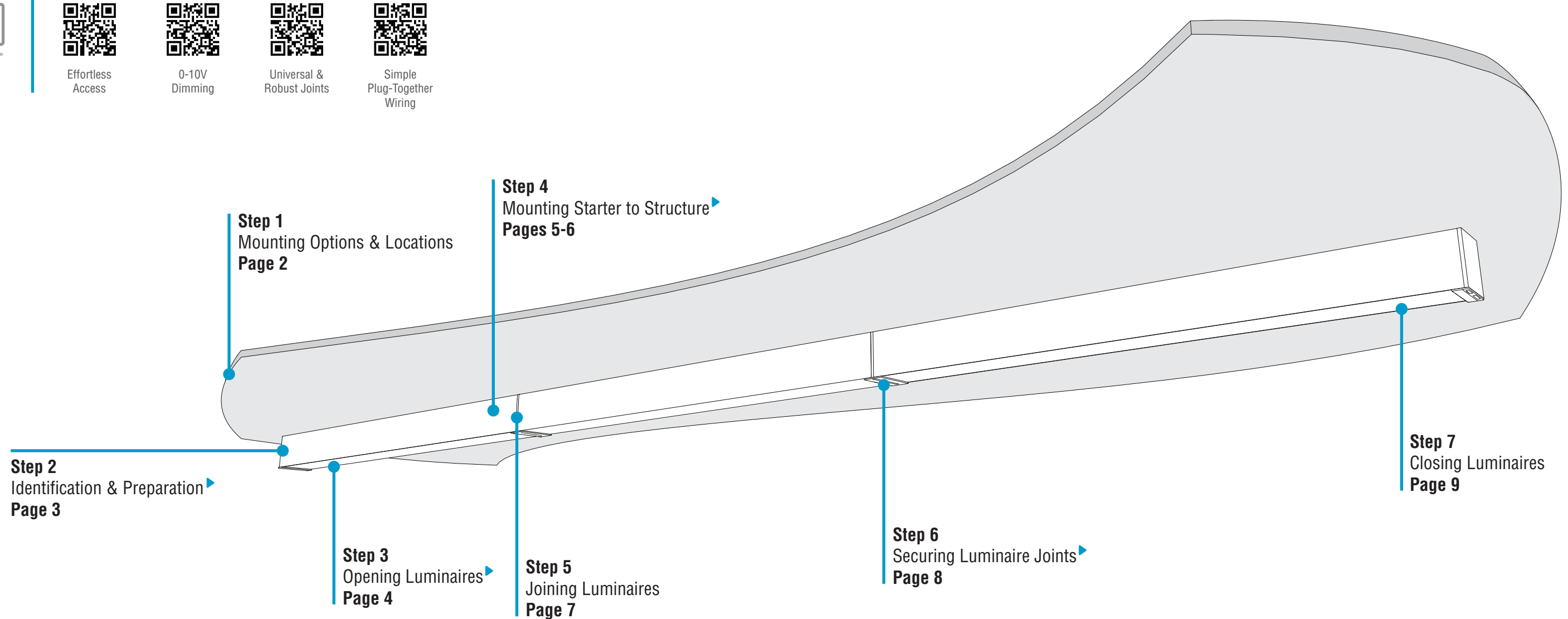

Step 1
Mounting Options & Locations
Page 2

Step 4
Mounting Starter to Structure
Pages 5-6

Step 2
Identification & Preparation
Page 3

Step 3
Opening Luminaires
Page 4

Step 5
Joining Luminaires
Page 7

Step 6
Securing Luminaire Joints
Page 8

Step 7
Closing Luminaires
Page 9

HP-4 Wet Location Surface Mount Installation Instructions

Step 1 - Mounting Options & Locations

Mounting Options

Option 1 - Mount to Threaded Rod

- Install threaded rods to structure.
- Threaded rod must extend into luminaire at least 3/4", no more than 1-1/2".
- Install wet rated electrical junction box and wet rated electrical conduit at feed locations.
- Remove preinstalled grommets (○) to use mounting holes.
- **NOTE:** Only remove grommets (○) at required mounting hole locations.

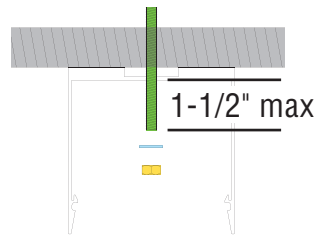

Option 2 - Mount to Support Structure

- Install wet rated electrical junction box and wet rated electrical conduit at feed locations.
- Remove preinstalled grommets (○) to use mounting holes.
- **NOTE:** Only remove grommets (○) at required mounting hole locations.

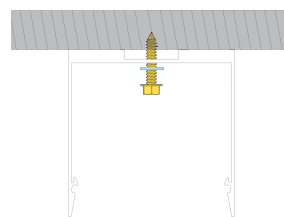

Mounting Locations

X = Luminaire section length
(X Measurements do not include endcaps or joint adapters)

	Z = Mounting Hole Location (Does not include endcaps or joint adapters)	V = Feed Location
HP-4	6"	2-1/4"

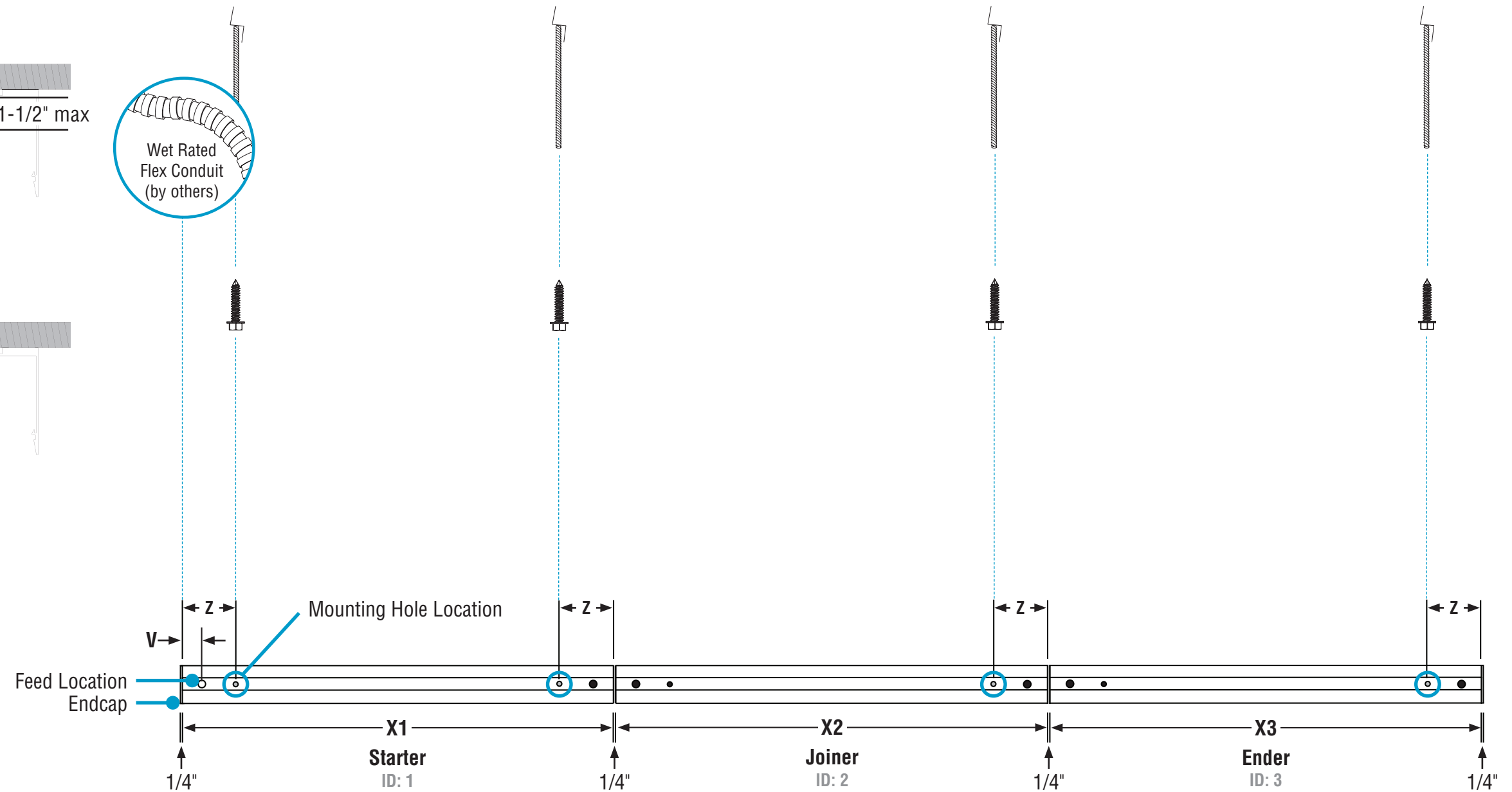

- Luminaire mounting holes sized for 1/4"-20 hardware.
- Refer to Record Drawings and building plans to determine exact mounting, suspension points, and power feed locations.
- **CRITICAL:** Must be secured to support blocking (studs). Luminaire body must be fully mounted and flush to solid structure.

NOTE:
All HP-4 Wet Location luminaires CANNOT be installed upside down for indirect / uplight illumination. All HP-4 Wet Location luminaires are direct / downlight illumination only.

Mounting Option 1

- Threaded Rod (by others)
- 1/4"-20 Sealing Washer (provided)
- 1/4"-20 Nut (by others)

Mounting Option 2

- 1/4"-20 Lag Bolt (by others)
- 1/4"-20 Sealing Washer (provided)

Wet Rated Flex Conduit (by others)

Grommet (provided)

HP-4 Wet Location Surface Mount Installation Instructions

Step 2 - Identification & Preparation

A. Identify Luminaires



CAUTION

Arrange luminaires in order according to ID# at their install locations.

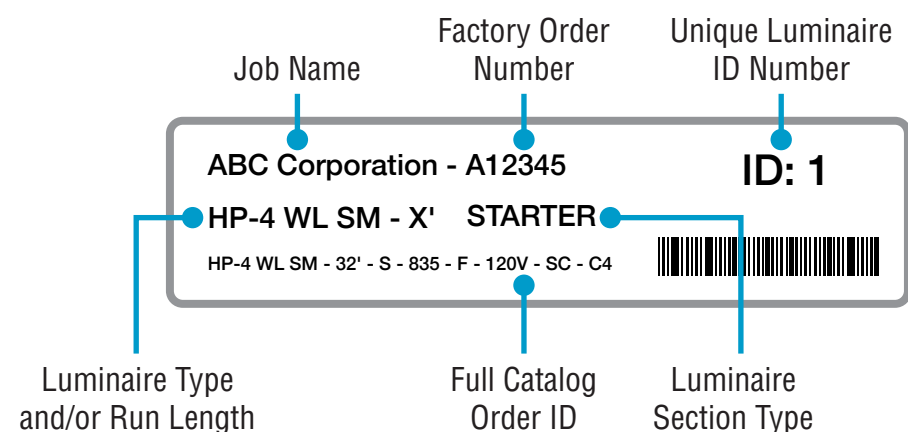

- Identify all luminaires by their ID label that can be found on the box, the diffuser, and inside the luminaire.
- **NOTE:** Exact location of labels in these areas may vary.
- Remove all luminaires from their box.
- Refer to record drawings that can be found in the hardware kit.

B. Remove Diffusers & Grommets at Required Locations Top-Down View

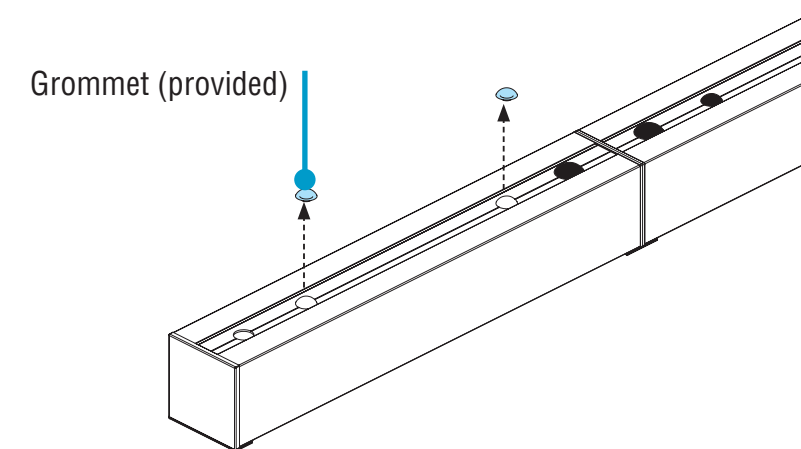
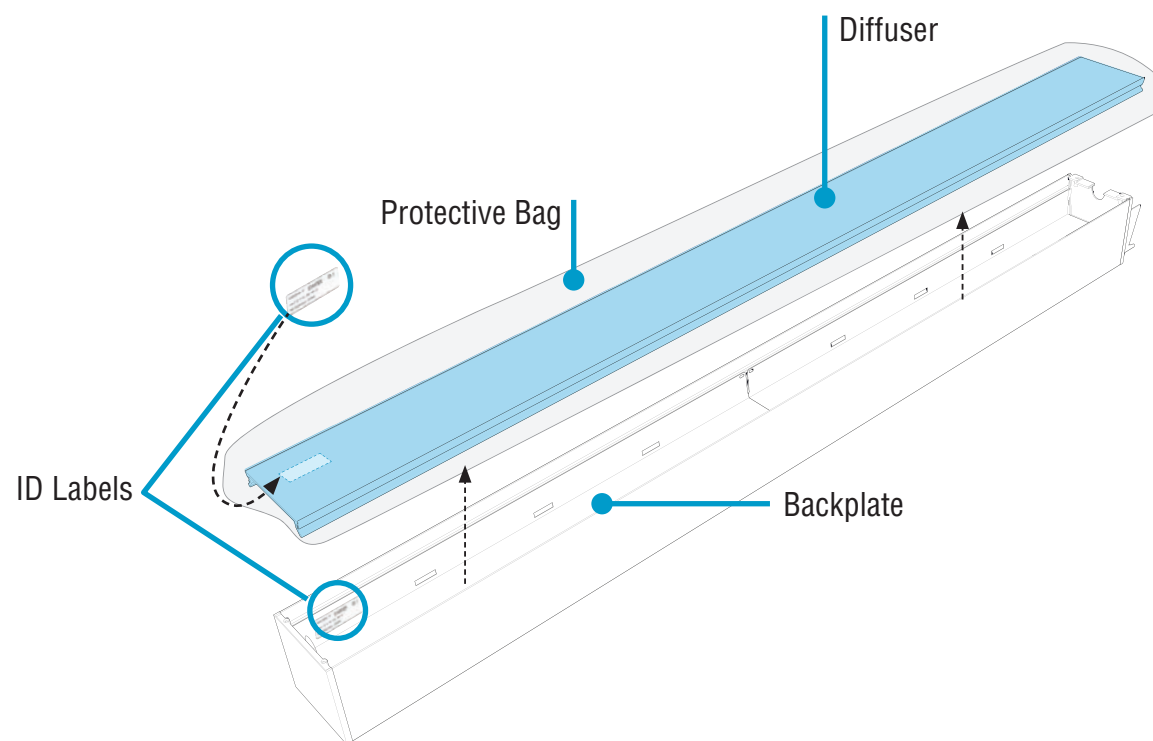

- Carefully remove all diffusers, keeping them inside their protective bags.
- Set aside all diffusers to prevent them from getting dirty or damaged.
- Ensure diffusers can be clearly identified back to their corresponding luminaire.
- Use a flathead screwdriver to remove grommets at required mounting hole locations.

Kitted Hardware

- Finelite has provided items listed here, with their Finelite part numbers. These items can be found in separate boxes shipped with the luminaire.
- Account for all parts and set aside until they are needed.
- All other hardware needed for this installation will be by others.

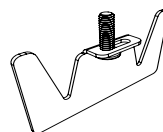

Yoke Bracket
Part# 43659

Washer
Part# 94111

#10-32 x 5/8" Screw
Part# 94144
Securing Luminaire Joints
p. 8, Step 6



Nylon Nut
Part# 43695
Mounting Starter to Structure
p. 5, Step 4



1/4"-20 Sealing Washer
Part# 76407
Mounting Starter to Structure
p. 6, Step 4
Joint Luminaires
p. 7, Step 5



Sealing O-Ring
Part# 43696
Mounting Starter to Structure
p. 5, Step 4



Diffuser Screw
#6-32 x 3/8" Screw - Part# 76404
Identification & Preparation
p. 3, Step 2
Closing Luminaires
p. 9, Step 7



Grommet
Part# 43694
Mounting Options & Locations
p. 2, Step 1
Identification & Preparation
p. 3, Step 2

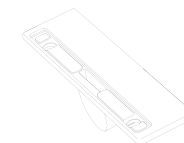

Endcap Diffuser Cover
Part# 43738
Identification & Preparation
p. 3, Step 2
Closing Luminaires
p. 9, Step 7



Screw Cover
Part# 43637
Identification & Preparation
p. 3, Step 2
Closing Luminaires
p. 9, Step 7

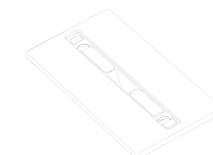

Joint Diffuser Cover
Part# 43740
Identification & Preparation
p. 3, Step 2
Closing Luminaires
p. 9, Step 7



Effortless
Access

HP-4 Wet Location Surface Mount Installation Instructions

Step 3 - Opening Luminaires

Release Backplates Top-Down View

Putty Knife Option

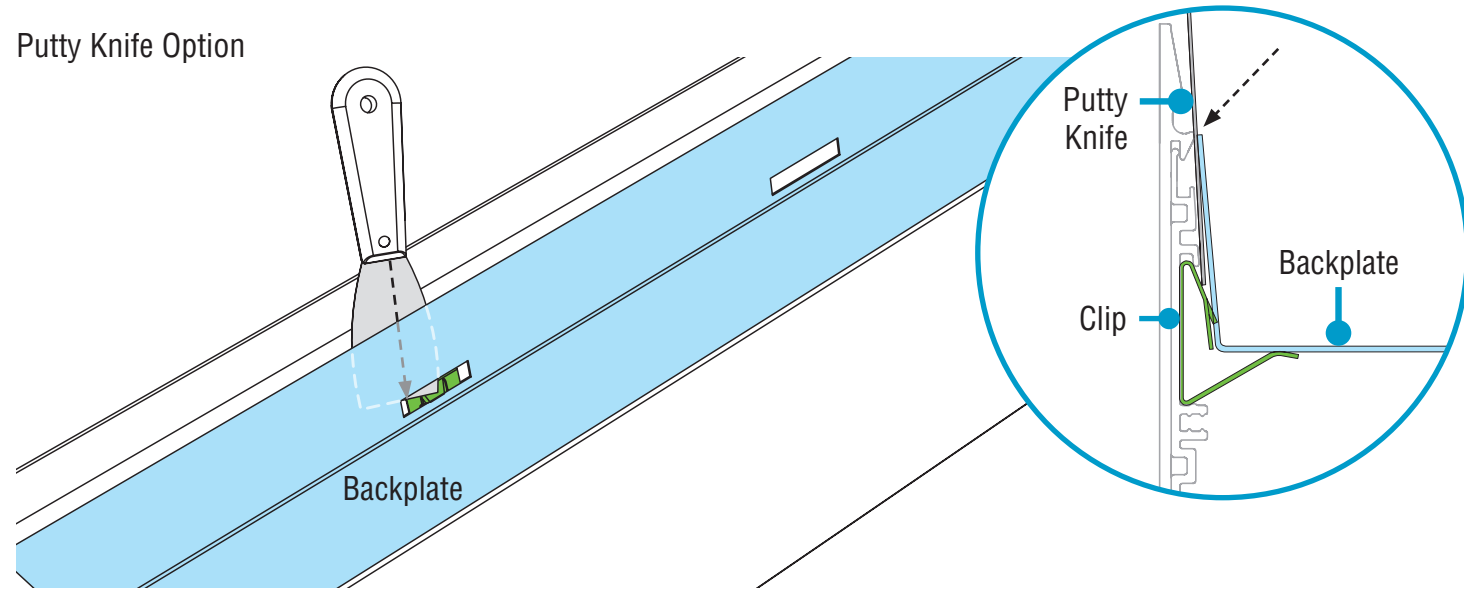

Flathead Screwdriver Option

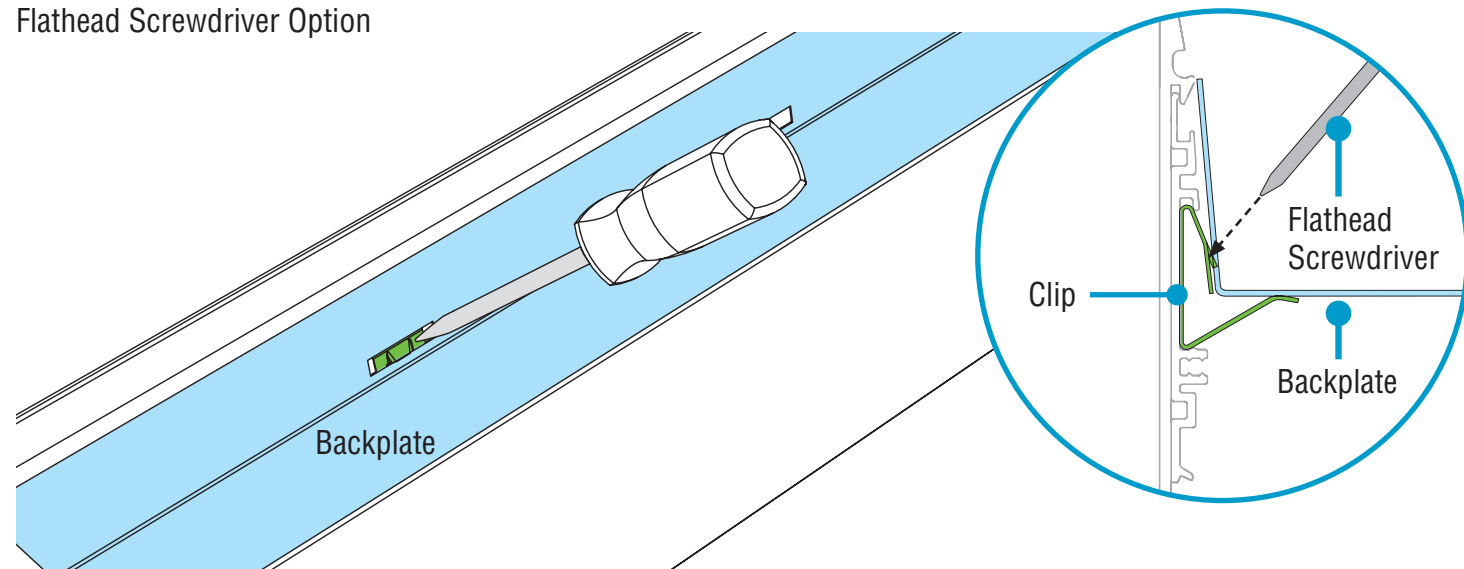

- Open all backplates for access to mounting points.
- Release the backplates from clips by sliding the blade of a putty knife behind backplate edges.
- To use a flathead screwdriver: From inside backplate, press end of screwdriver against the clip until the backplate is released.

- Carefully rotate all backplates out and let them hang from luminaire body.

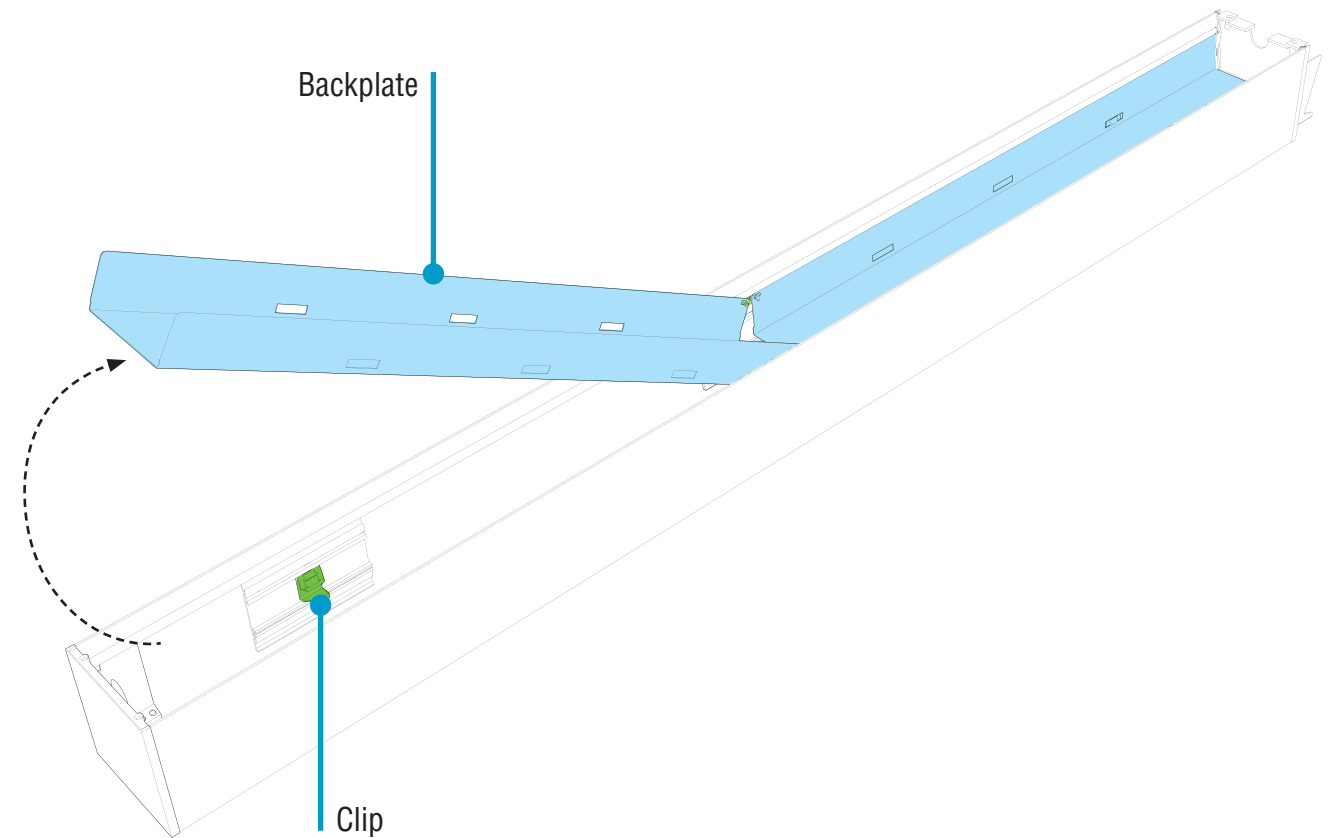

Effortless
Access

HP-4 Wet Location Surface Mount Installation Instructions

Step 4 - Mounting Starter to Structure

A. Make Electrical Connections Bottom-Up View

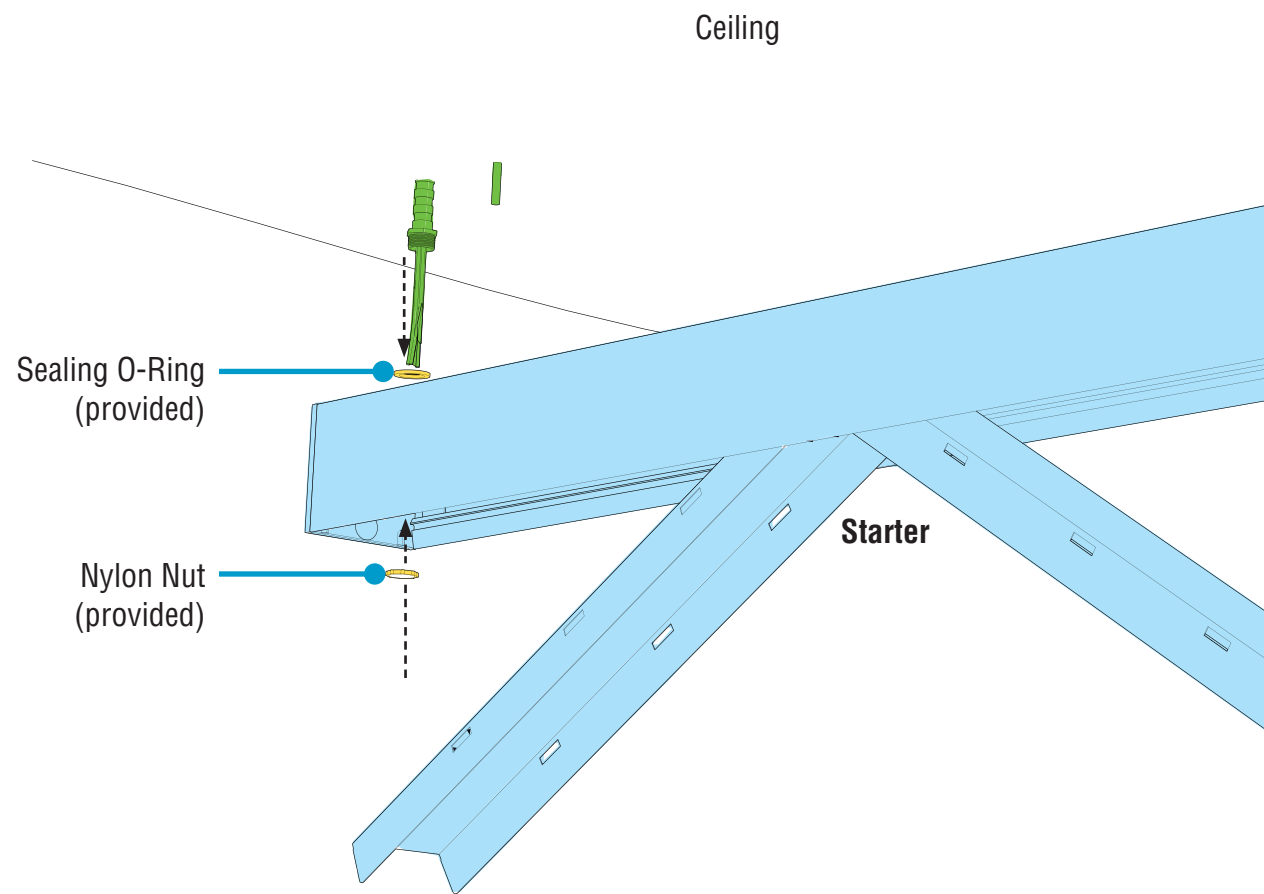

- While properly supporting luminaire, maneuver luminaire near wall/ceiling.
- Make electrical connections at **TOP** of luminaire.

Top-Down View

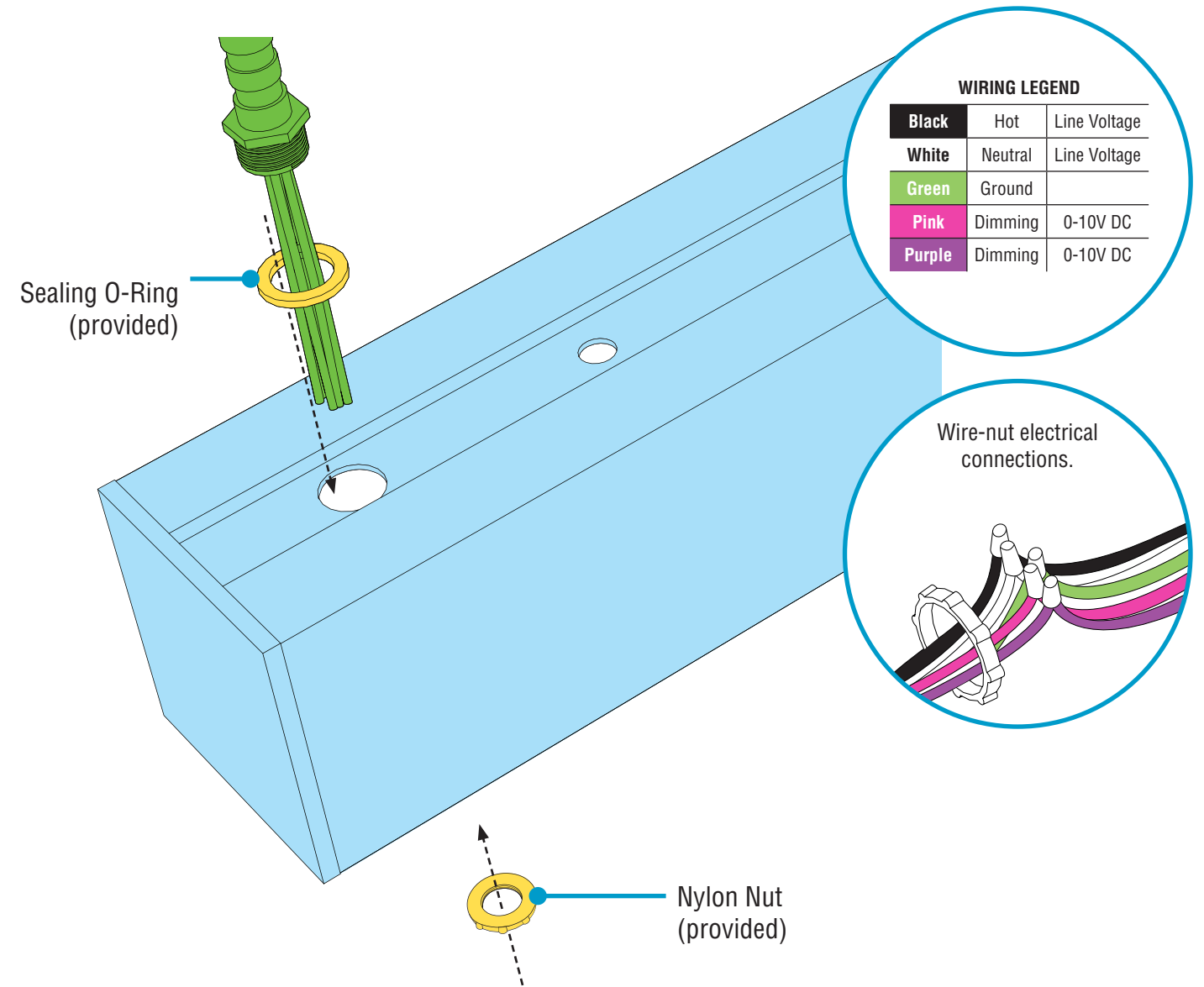

- Install conduit, sealing o-ring, and nylon nut onto the luminaire.
- Wire-nut electrical connections. See wiring legend above.



CONTINUED



0-10V
Dimming

HP-4 Wet Location Surface Mount Installation Instructions

Step 4 - Mounting Starter to Structure

B. Mount Starter to Structure Bottom-Up View

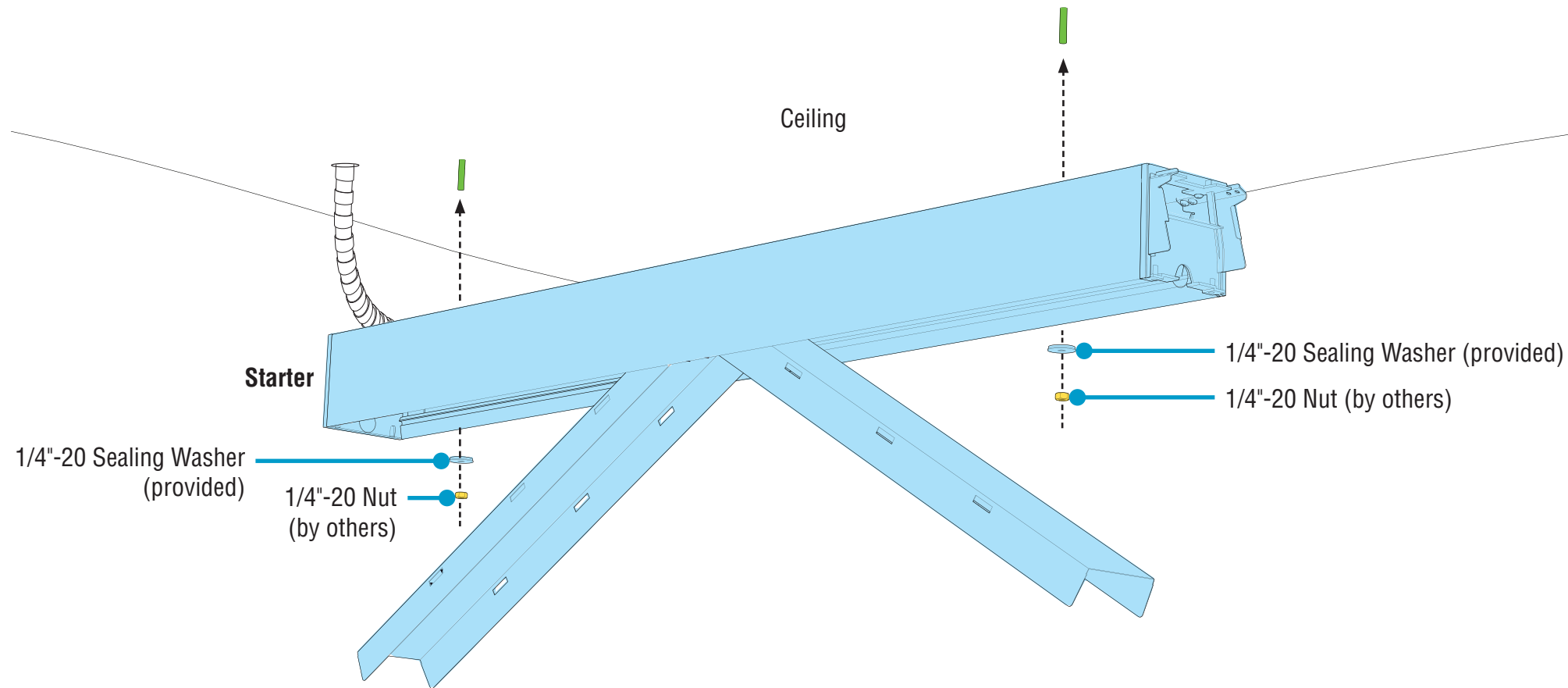

Option 1 (Shown) - Mount to Threaded Rod

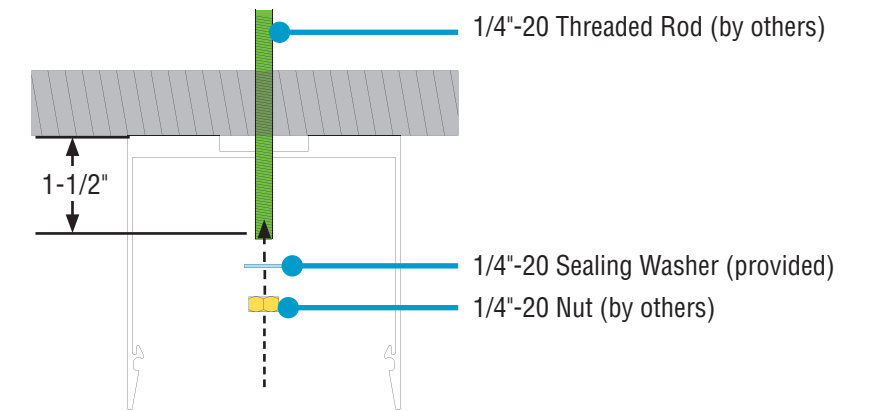

Option 2 - Mount to Structure

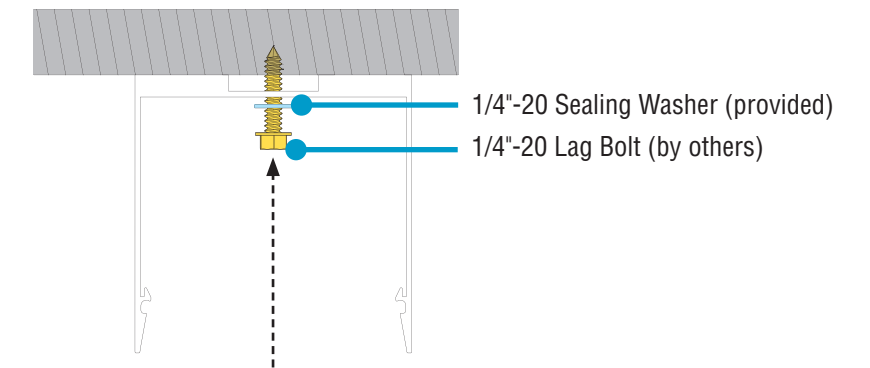

Option 1 (Shown) - Mount to Threaded Rod

- Align mounting holes with hanging hardware.
- Install 1/4"-20 nut and 1/4"-20 sealing washer onto 1/4"-20 threaded rod.
- **CRITICAL:** If installing a joiner luminaire in the next step, leave nut loose, allowing luminaire to hang at an angle.
- If there is no joiner/ender, then tighten nuts fully. **PROCEED TO STEP 7.**

Option 2 - Mount to Structure

- Place luminaire onto wall/ceiling and mount to structure support with hardware appropriate for the structure type.
- **CRITICAL:** If installing a joiner luminaire in the next step, leave loose, allowing luminaire to hang at an angle.
- If there is no joiner/ender, then tighten nuts fully. **PROCEED TO STEP 7.**

Mounting Option 1

- Threaded Rod (by others)
- 1/4"-20 Sealing Washer (provided)
- 1/4"-20 Nut (by others)

Mounting Option 2

- 1/4"-20 Lag Bolt (by others)
- 1/4"-20 Sealing Washer (provided)

HP-4 Wet Location Surface Mount Installation Instructions

Step 5 - Joining Luminaires

A. Mount Joiner/Ender to Structure Bottom-Up View



CAUTION

DO NOT attempt to join luminaires together on the floor. Damage may result when lifted. Follow these instructions.

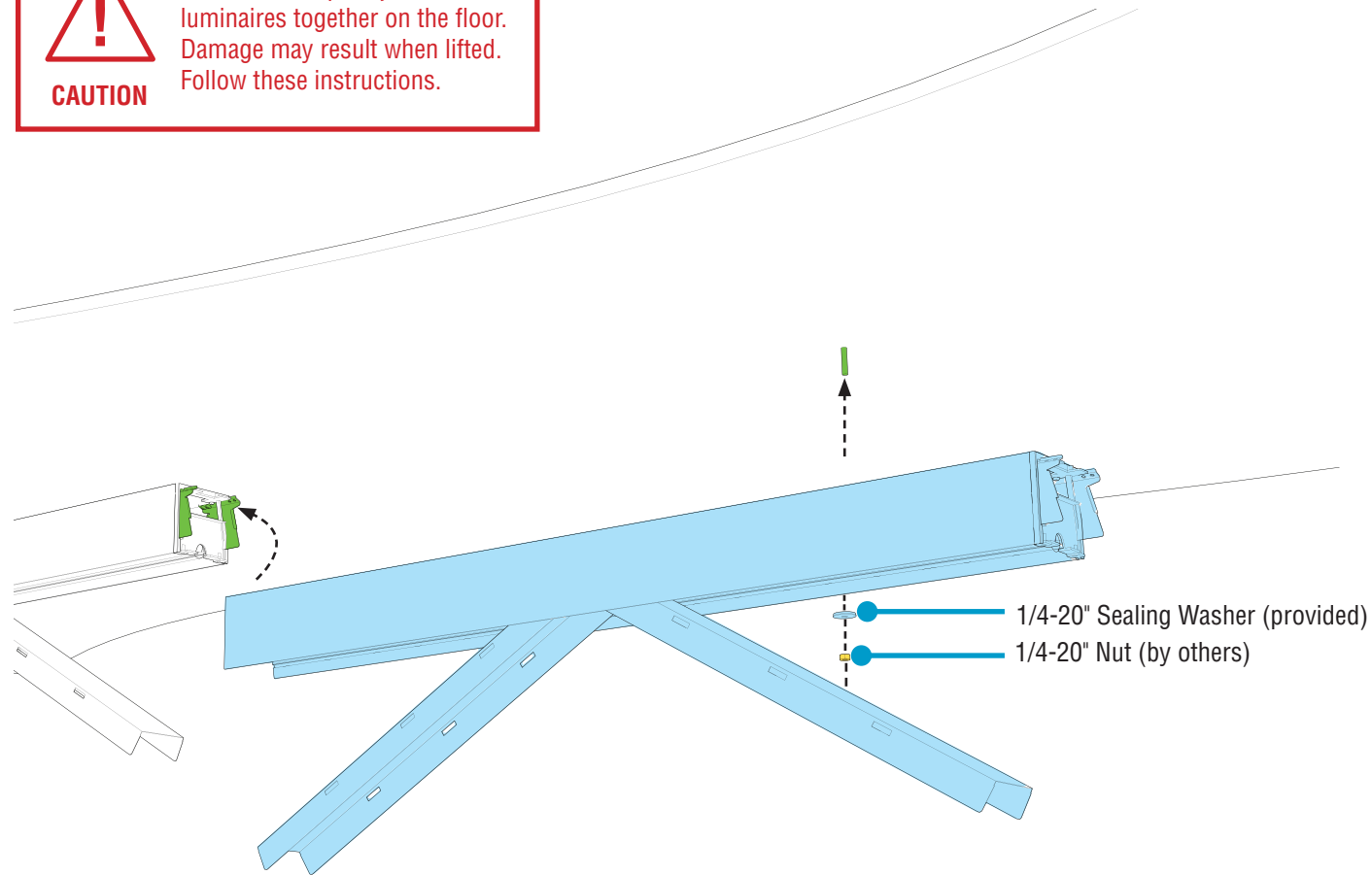

Option 1 (Shown) - Mount to Threaded Rod

- Align mounting holes with hanging hardware.
- Install 1/4"-20 nut and 1/4"-20 washer onto 1/4"-20 threaded rod.
- **NOTE:** If installing a joiner luminaire, leave nut loose, allowing luminaire to hang at an angle.
- If there is no joiner/ender, then tighten nuts fully.

Option 2 - Mount to Structure

- Mount to structure support with hardware appropriate for the structure type.
- **NOTE:** If installing a joiner luminaire, leave nut loose, allowing luminaire to hang at an angle.
- If there is no joiner/ender, then tighten nuts fully.

B. Join Luminaires Bottom-Up View



CAUTION

Once luminaires are aligned together, **joiner luminaire is not yet secure.** Ensure it does not slide off as it rests on the starter luminaire.

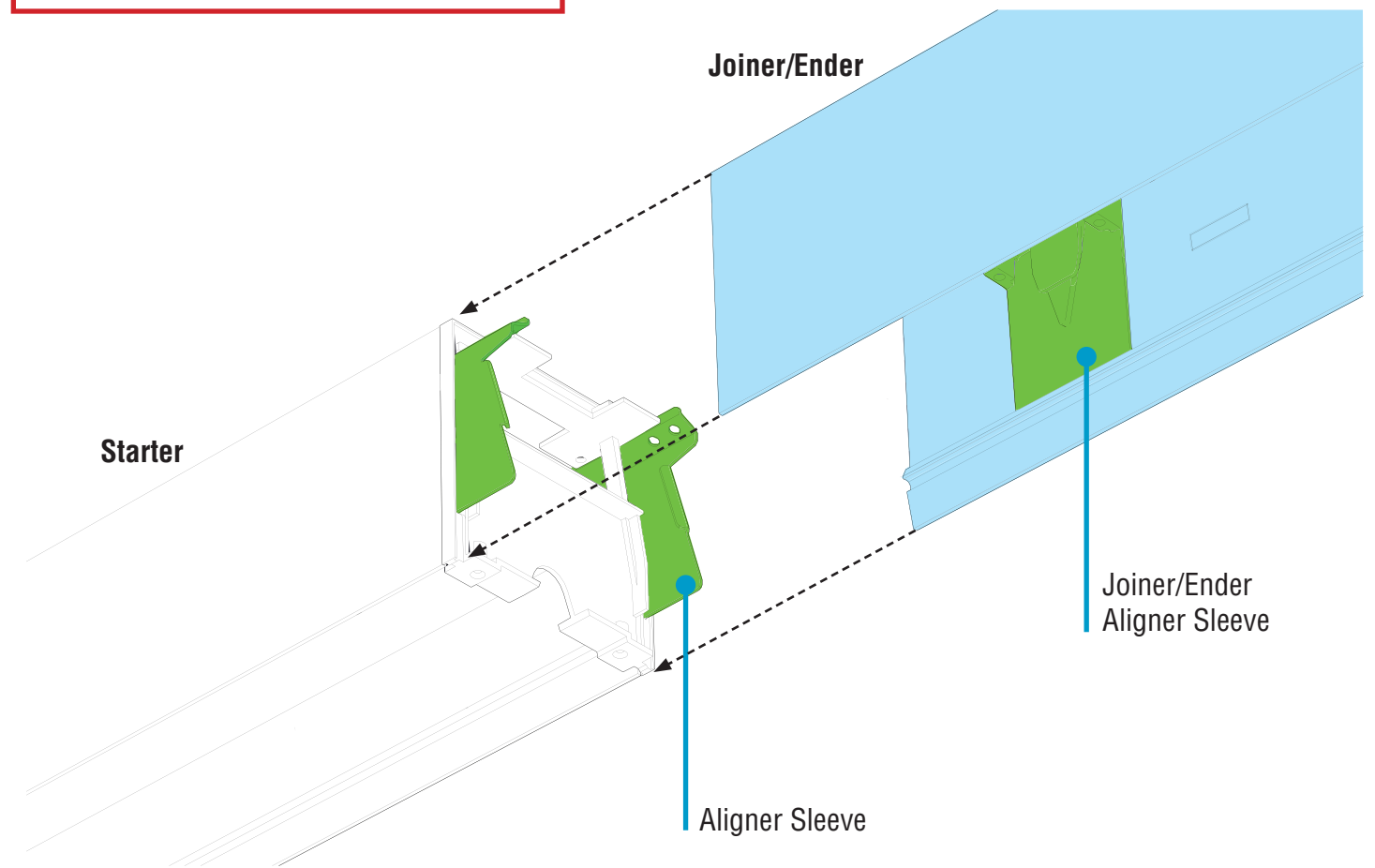

- Align joiner/ender with aligner sleeves on starter and slide together. Be careful not to damage any wiring.
- If necessary, **lift** both luminaires, then slide them together.

Mounting Option 1

Threaded Rod
(by others)



1/4"-20 Sealing Washer
(provided)



1/4"-20 Nut
(by others)

Mounting Option 2



1/4"-20 Lag Bolt
(by others)



1/4"-20 Sealing Washer
(provided)



Universal &
Robust Joints

HP-4 Wet Location Surface Mount Installation Instructions

Step 6 - Securing Luminaire Joints

A. Secure Joint with Yoke Brackets Bottom-Up View

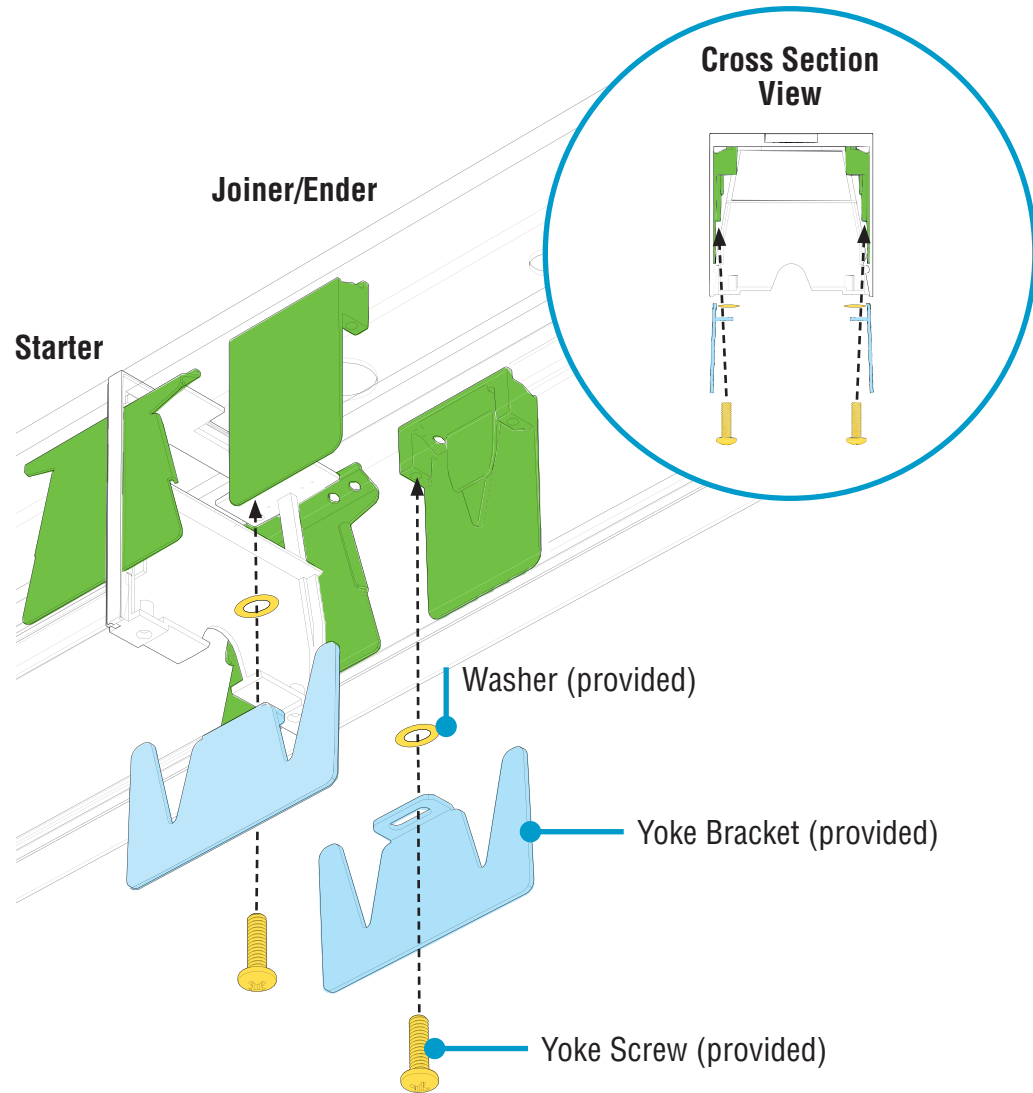

- Before installing yoke brackets, ensure the joining ends of luminaires meet flush and square.
- **CRITICAL:** Ensure yoke brackets properly engage with aligner sleeves.
- Secure joint by threading (but not yet tightening) yoke screws through yoke brackets and washers and into the aligner sleeves.
- Tighten yoke screws¹ until joint seam of luminaires is closed.

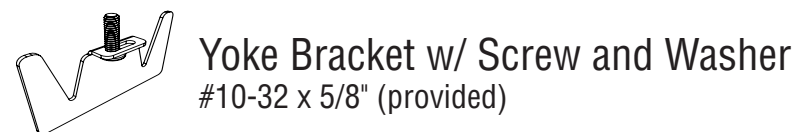

¹ Screwdriver with 6\"/>

IN ALIGNMENT

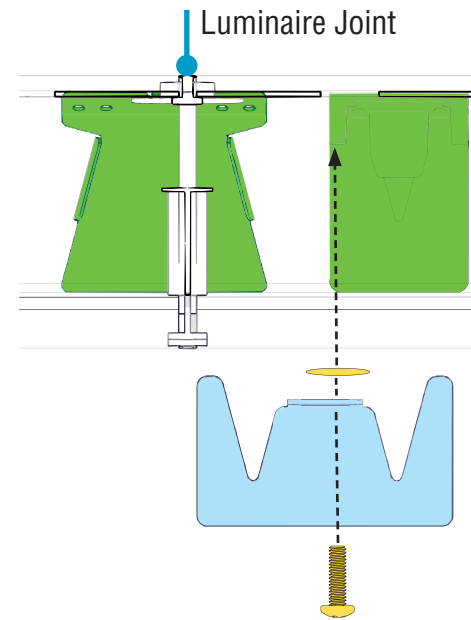

CORRECTLY INSTALLED

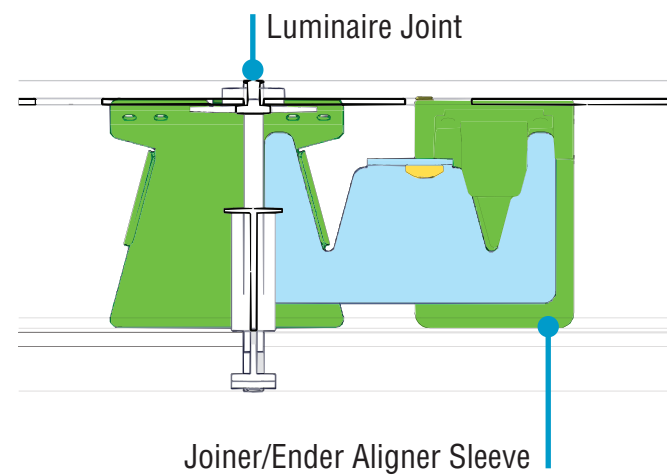

B. Make Electrical Connections Bottom-Up View

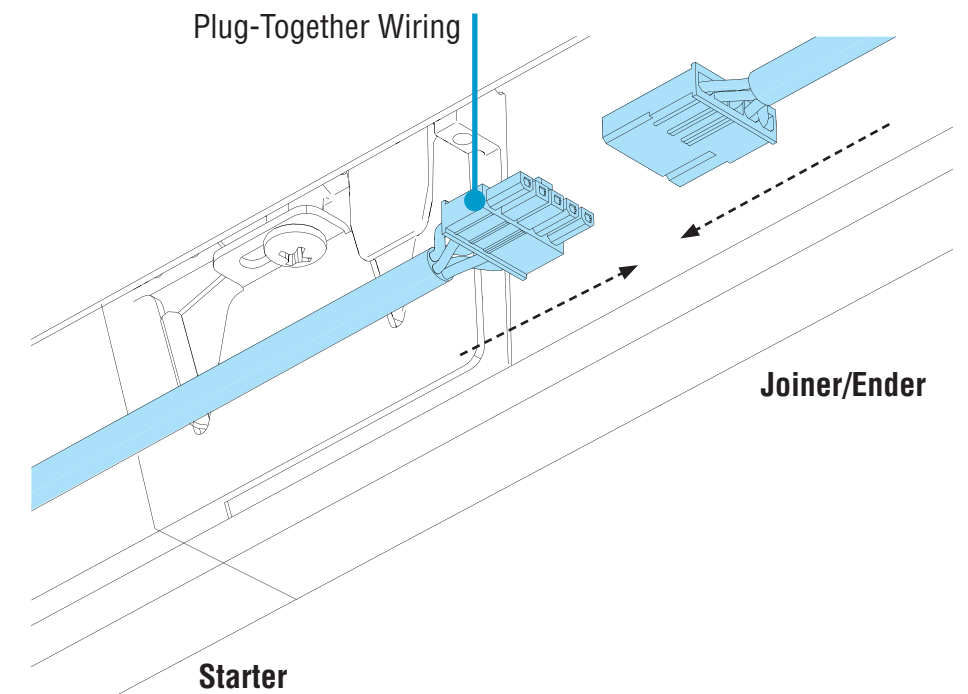

- Connect plug-together wiring.



Universal & Robust Joints



Simple Plug-Together Wiring

HP-4 Wet Location Surface Mount Installation Instructions

Step 7 - Closing Luminaires

Final Step - Replace Backplates, Diffusers & Diffuser Covers Bottom-Up View

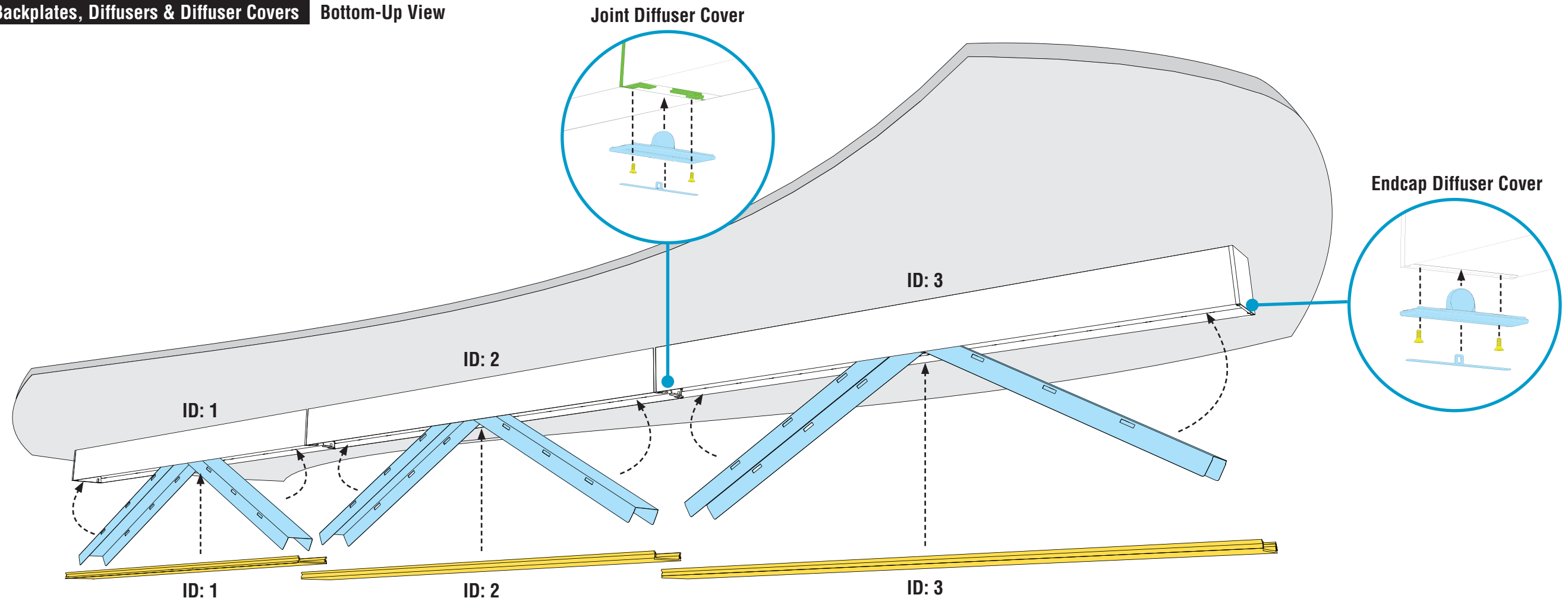

- **NOTE:** If your installation includes a battery backup, please see addendum (98333) that should be included with your kitting package.
- Reinstall any open backplates by rotating into luminaire body and snapping back into clips.
- Remove diffusers from protective plastic bag.
- **CAUTION:** Wear gloves to keep diffuser surface clean, take care to wipe off any water or condensation on diffusers before installing into luminaire.
- **CRITICAL:** Be sure to install correct diffuser to its corresponding luminaire ID.
- Install diffusers into luminaire body, ensuring they snap into place.
- Reinstall all endcap and joint diffuser covers.
- Turn power on to luminaire.

