

HPO Driver Replacement Instructions

Overview

NOTES

- All power connections should be installed according to local/national codes by a Certified Electrician.



HELPFUL
VIDEO



0-10V
Dimming

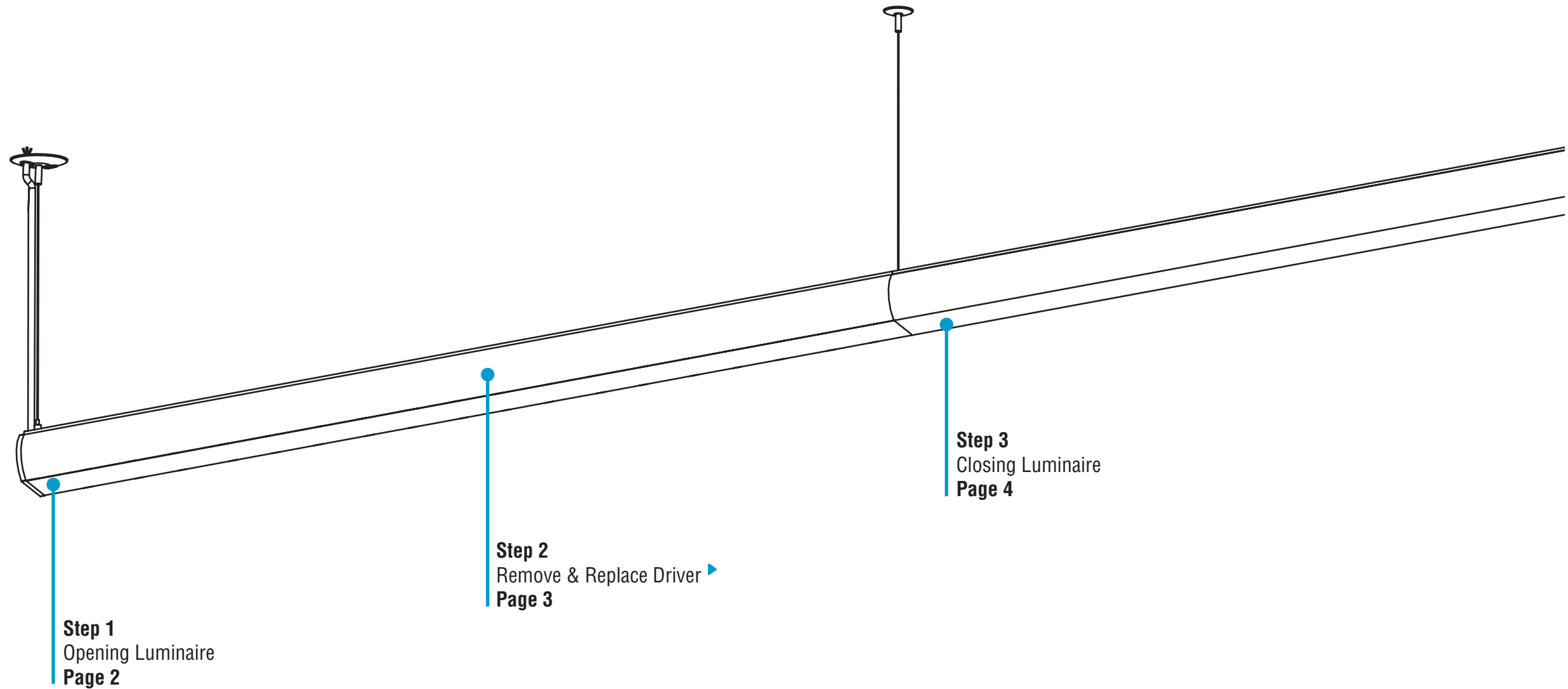

HPO Driver Replacement Instructions

Step 1 - Opening Luminaire

A. Remove Diffuser Bottom-Up View



Wear gloves to keep diffuser surface clean.

CAUTION

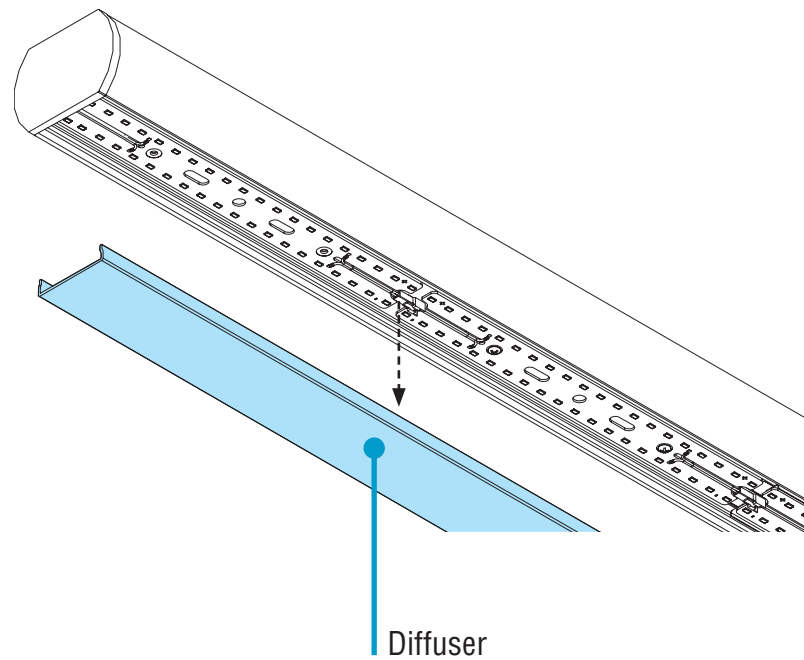

- Turn power off to luminaire.
- **CAUTION:** Wear gloves to keep diffuser surface clean.
- Carefully remove diffuser and set aside to prevent from getting dirty or damaged.

B. Remove Backplate Bottom-Up View

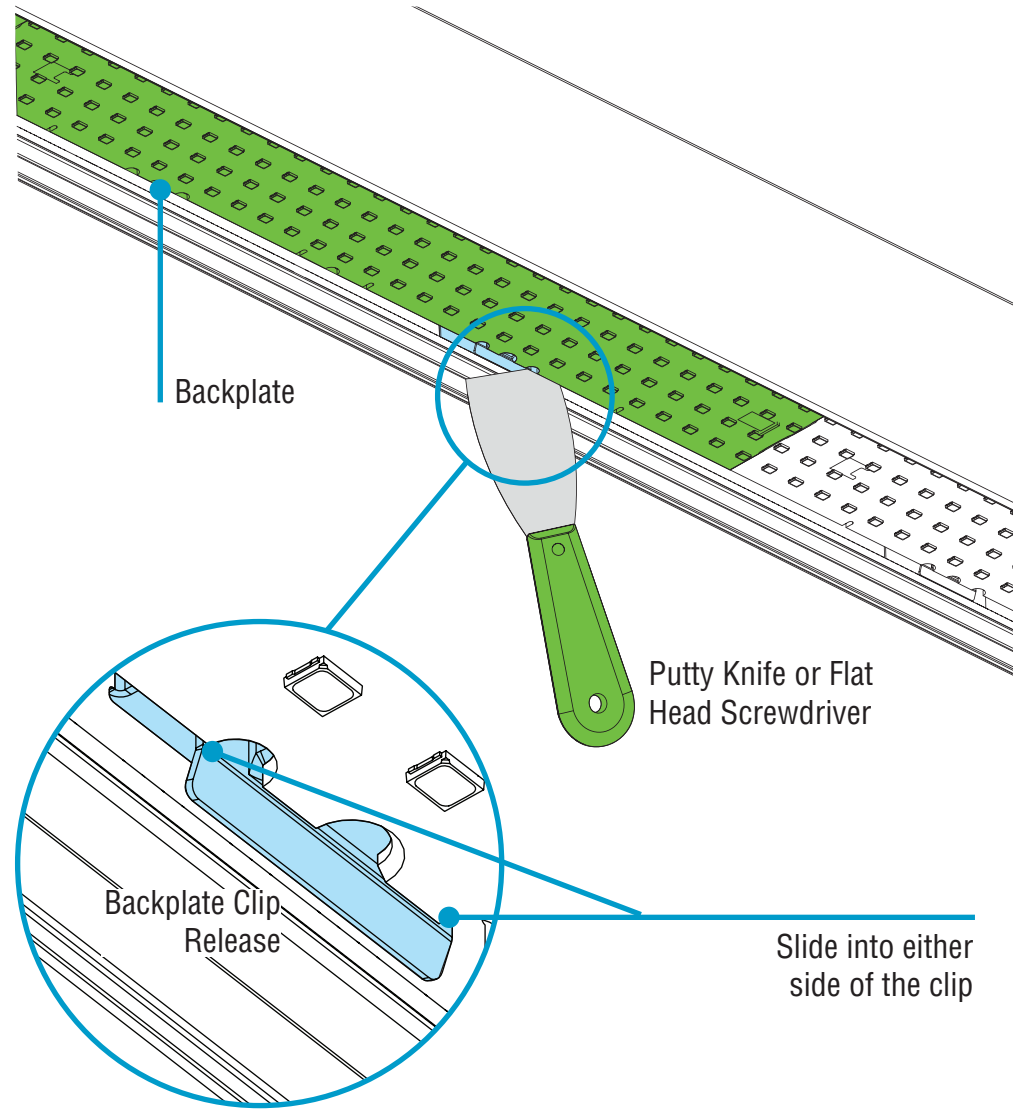

- Locate the backplate clip and use Putty Knife or Flat Head Screwdriver slide into either side of the clip
- Apply mild pressure to backplate when Putty Knife or Flat Head Screwdriver pushing into backplate clip release

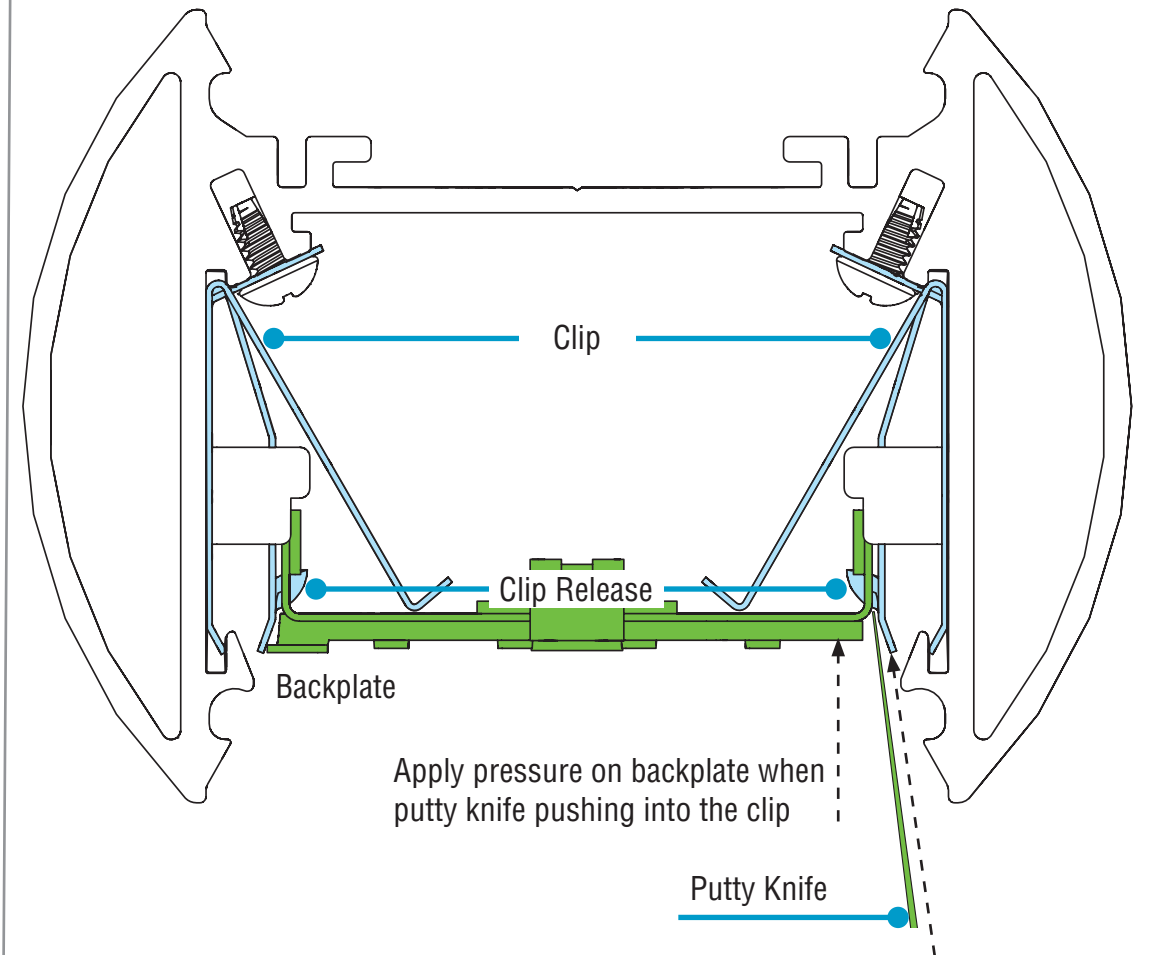

- Hear a click sound to release the backplate
- Four backplate clip per LED backplate. Release all four before remove backplate



#6-20 x 5/16" Flathead Screws
(provided)

HPO Driver Replacement Instructions

Step 2 - Remove & Replace Driver

A. Release & Remove Driver Bottom-Up View

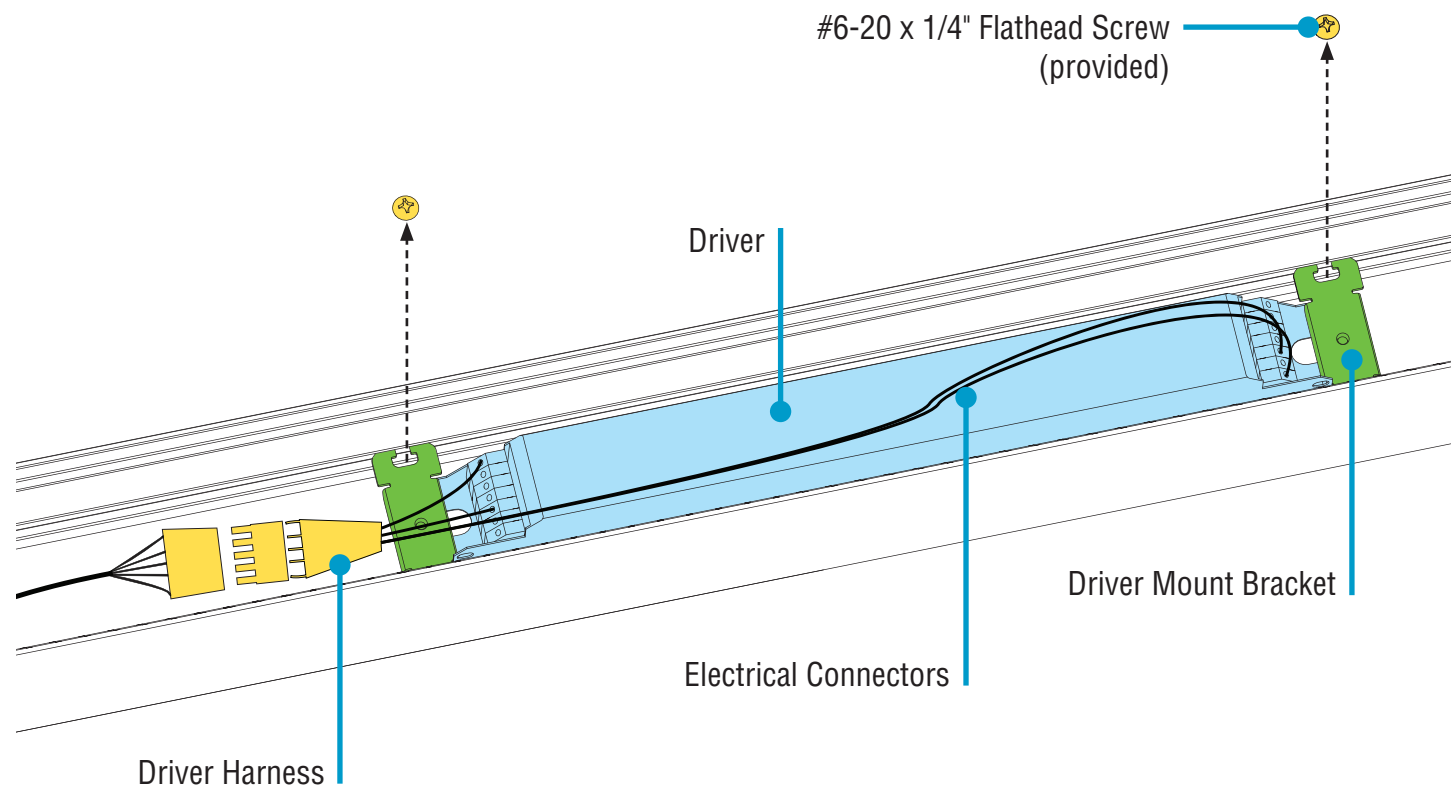

- Remove #6-20 x 1/4" Flathead screws from driver mount brackets.
- Remove driver mount brackets.
- Disconnect driver from driver harness.
- Once driver is free, disconnect electrical connections from the driver.
- Remove driver from luminaire.



#6-20 x 1/4" Flathead Screws
(provided)

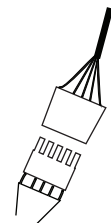

Driver Harness
Part # 15501

B. Replace Driver Bottom-Up View

WIRING LEGEND		
Black	Hot	Line Voltage
White	Neutral	Line Voltage
Green	Ground	
Pink	Dimming	0-10V DC
Purple	Dimming	0-10V DC

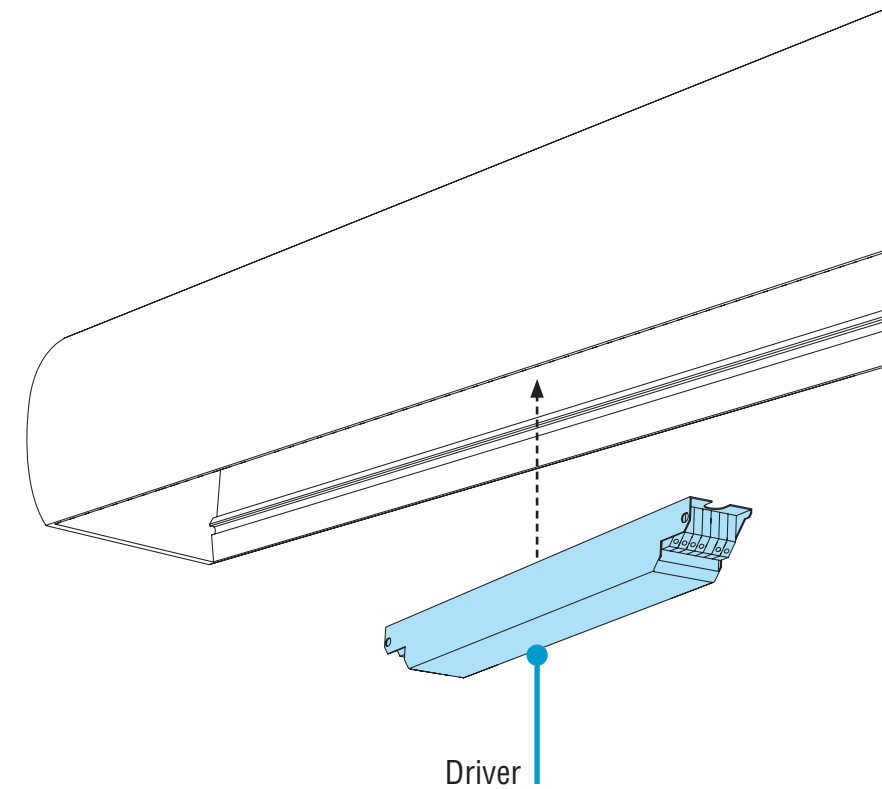

- Replace with new driver and reconnect electrical connections.
- Reconnect driver harness.
- Reinstall driver mount brackets by replacing #6-20 x 1/4" Flathead screws.



0-10V
Dimming

HPO Driver Replacement Instructions

Step 3 - Closing Luminaire

A. Replace Downlight LED Engine Bottom-Up View

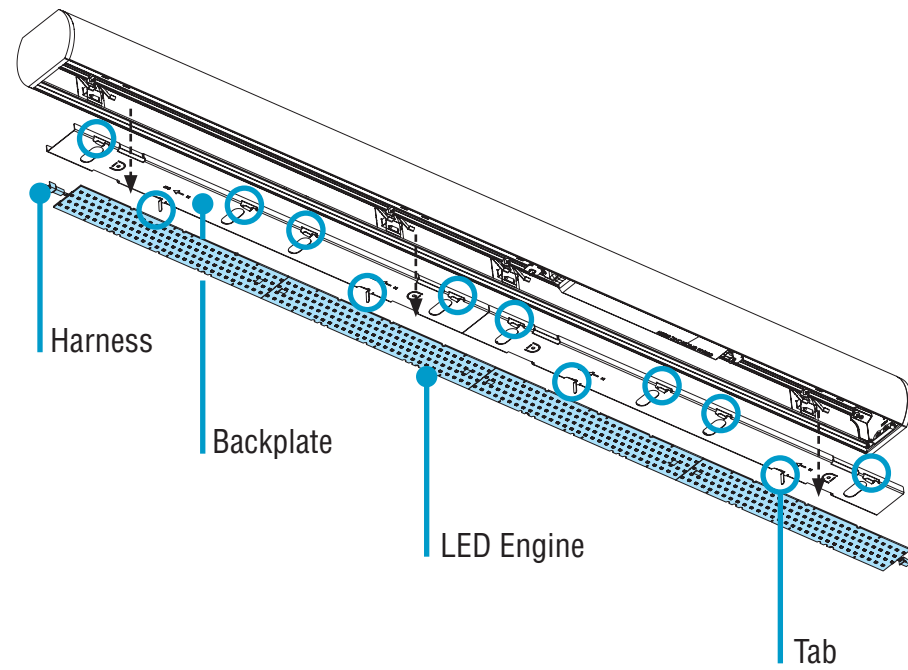

- Bend tabs to release LED engine from backplate.
- Replace with new LED engine and secure onto backplate with tabs.
- Reconnect harness to LED engine.

B. Replace Backplate Bottom-Up View

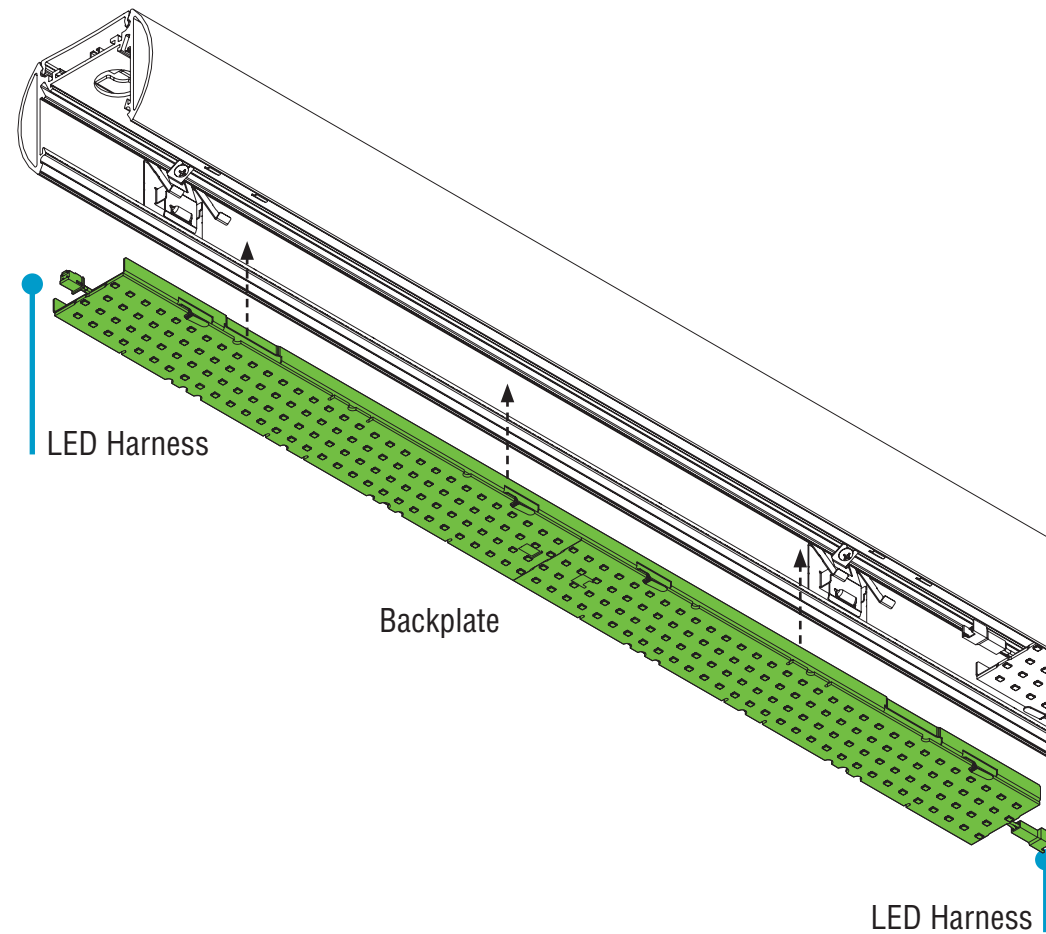

- Reinstall backplates by inserting into luminaire body. Hear 4 clicks per LED backplate. Make sure ALL LED backplate secure before install diffusers.

C. Final Step - Replace Diffuser Bottom-Up View

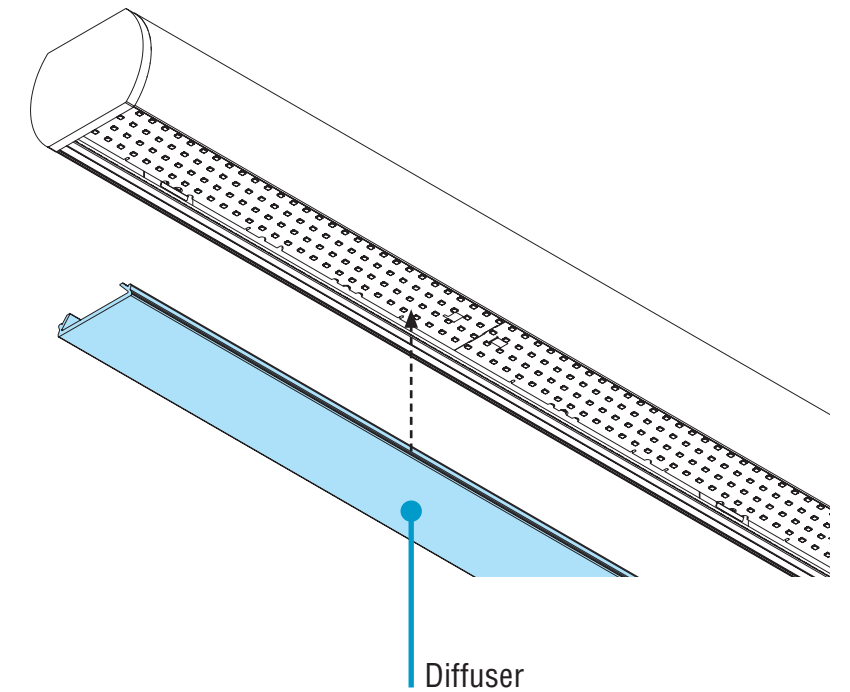

- **CAUTION:** Wear gloves to keep diffuser surface clean.
- Install diffuser into luminaire body, ensuring it snaps into place.
- Turn power on to luminaire.