

# HP-4 Recessed Flush Diffuser 1" Tegular Starter/Independent Installation Instructions

Scan QR code for helpful video(s)

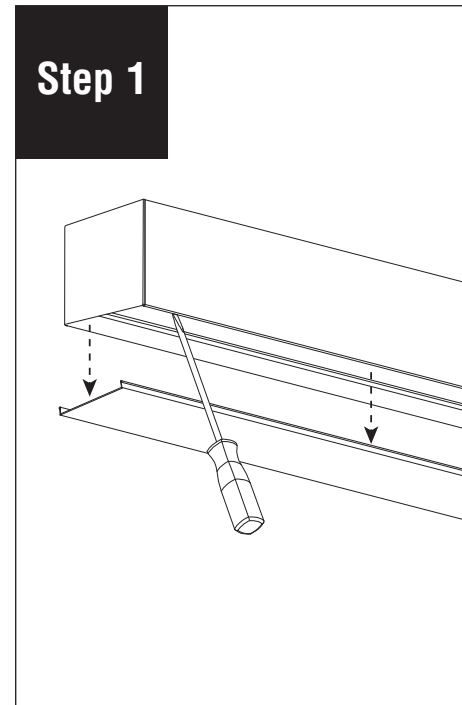

0 - 10V Dimming



Remove diffuser and set aside to prevent it from getting dirty or damaged.

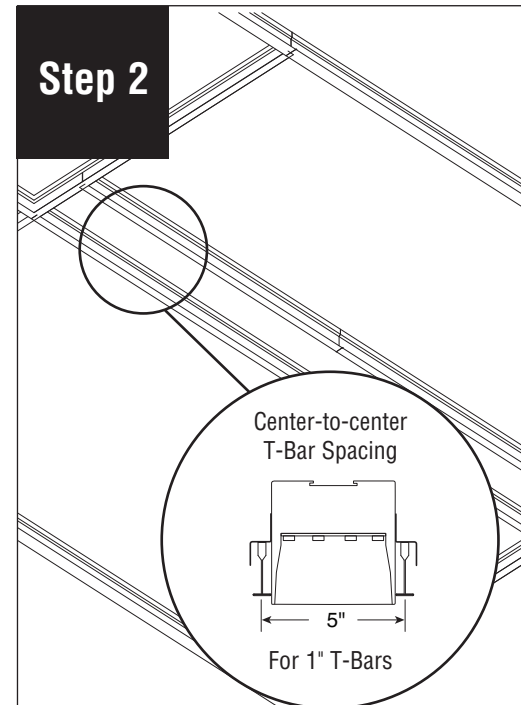

Configure T-Bar to luminaire size and leave an opening for luminaire. As noted above.

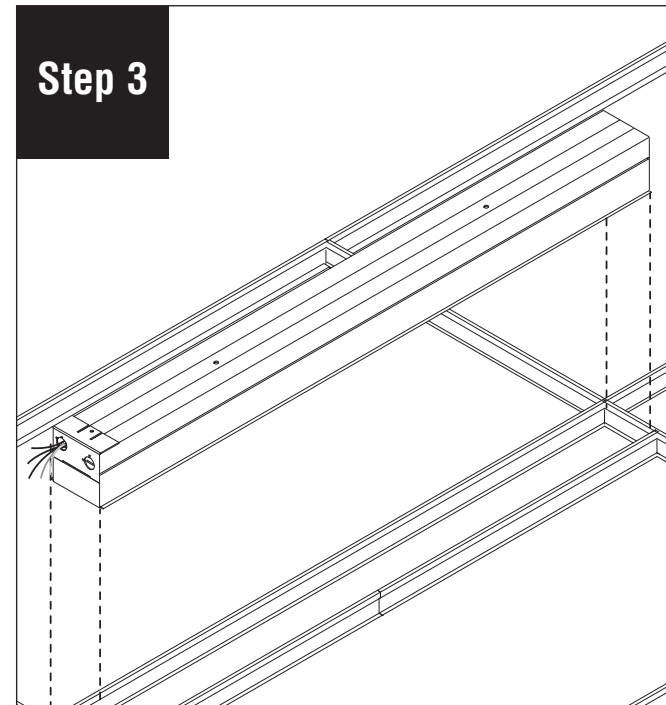

Place luminaire on T-Bar.

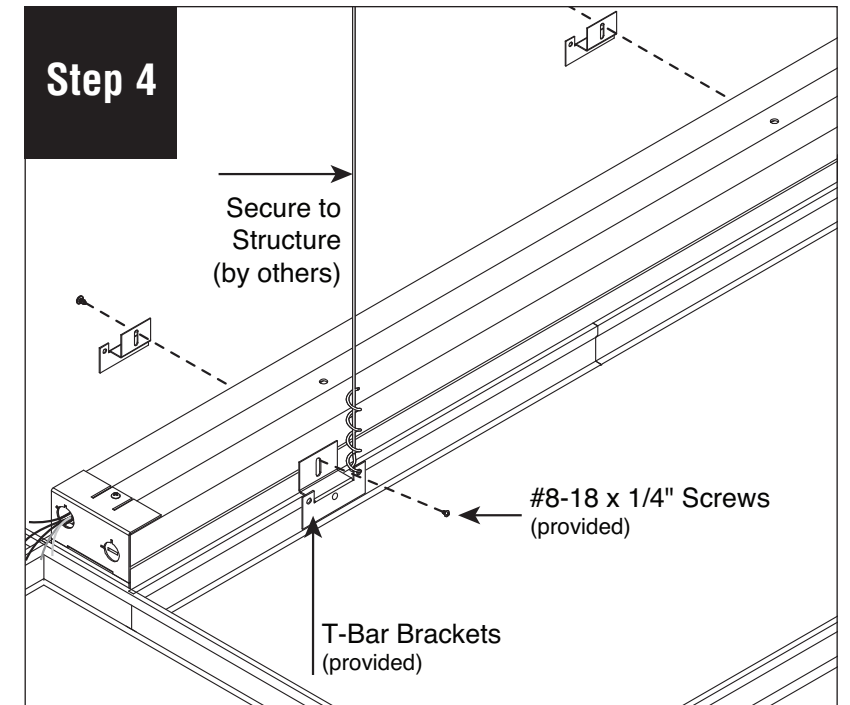

Install T-Bar bracket onto luminaire. Secure with #8-18 x 1/4" screws (provided). Secure luminaire to building structure using tie-wire, as per code.

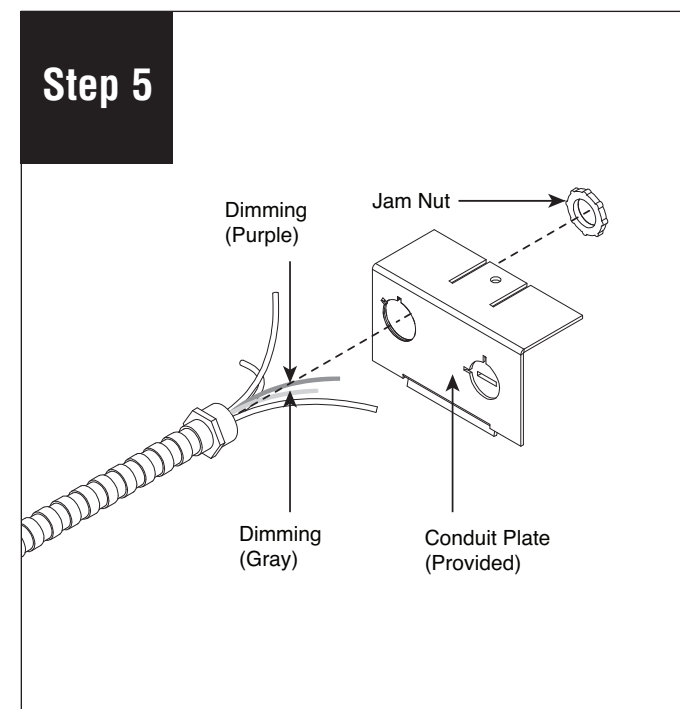

Remove conduit plate from end of luminaire and insert conduit through conduit plate. Secure conduit with jam nut. **NOTE:** Purple and gray wires are for Low Voltage Control.

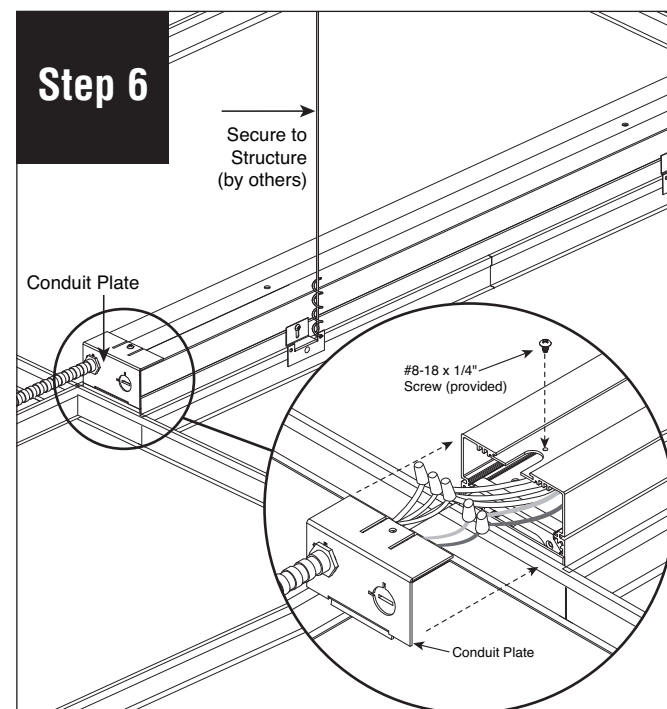

Make electrical connections and reinstall conduit plate to luminaire.

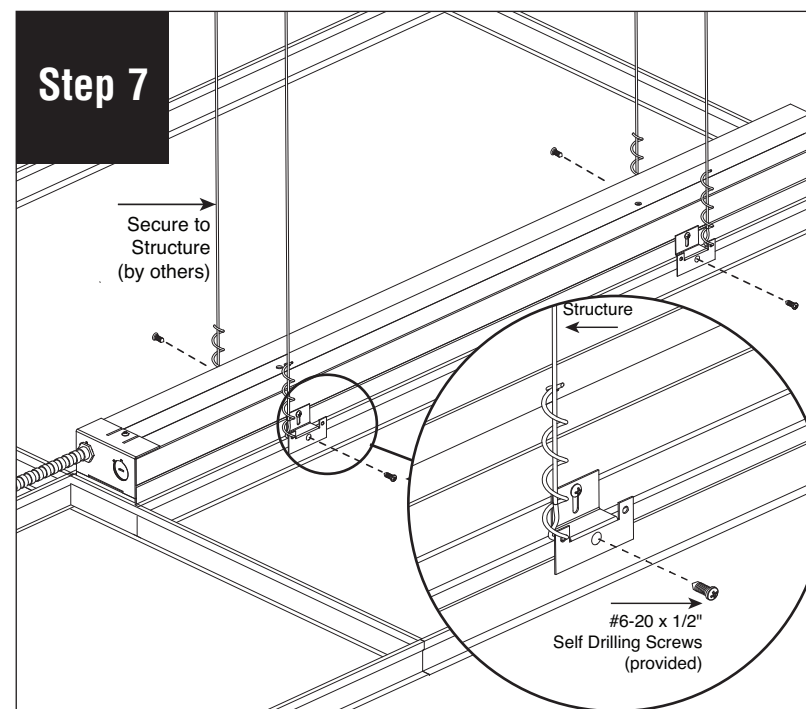

Secure luminaire to T-Bar by driving #6-20 x 1/2" self drilling screws (provided) through the T-Bar brackets (provided) into the T-Bar.

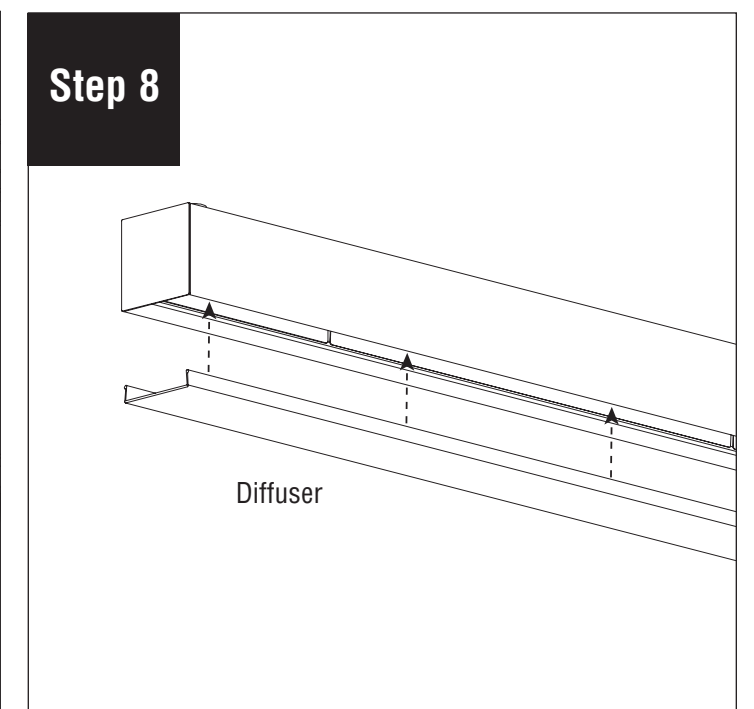

Reinstall diffuser and turn power on to luminaire. **NOTE:** If part of a longer run, diffuser will be reinstalled back into original luminaire section as lengths vary.

**Note:** All power connections to be installed to local/national codes by a Certified Electrician.

# HP-4 Recessed Flush Diffuser 1" Tegular Joiner/Ender Installation Instructions

Scan QR code for helpful video(s)



0 - 10V Dimming

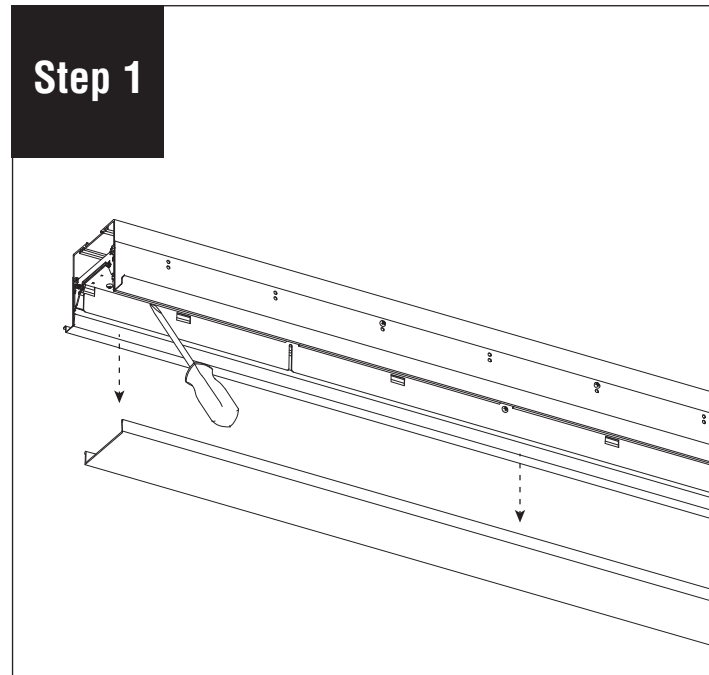

Remove diffuser and set aside to prevent it from getting dirty or damaged. **NOTE:** If part of a longer run, diffuser will be reinstalled back into original luminaire section as lengths vary.

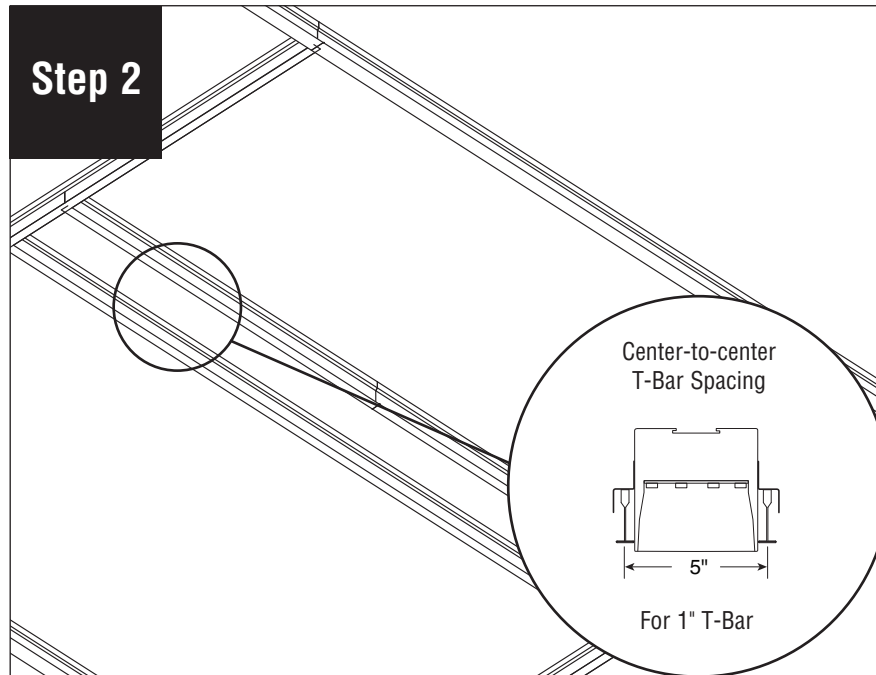

Configure T-Bar to luminaire size and leave an opening for luminaire. As noted above.

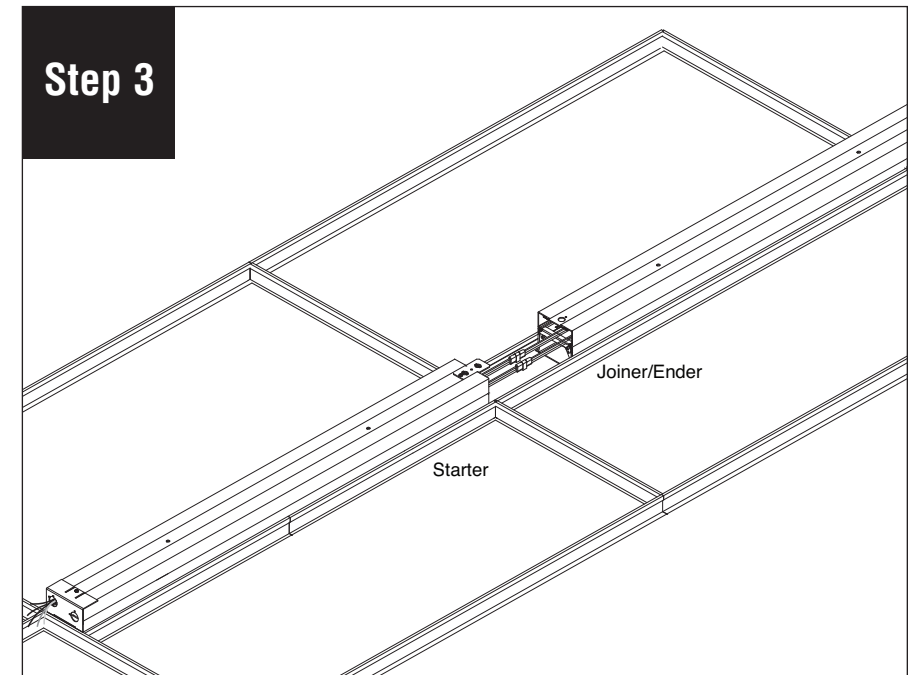

Place joiner/ender luminaire on T-Bar, next to the starter luminaire.

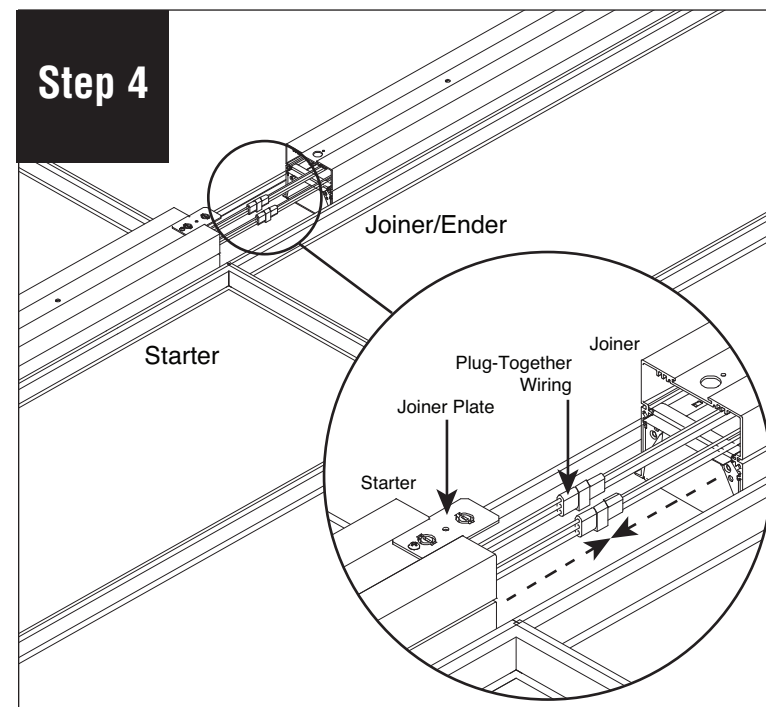

Connect plug-together wiring and align joiner/ender with joiner plate and carefully slide starter and joiner/ender together.

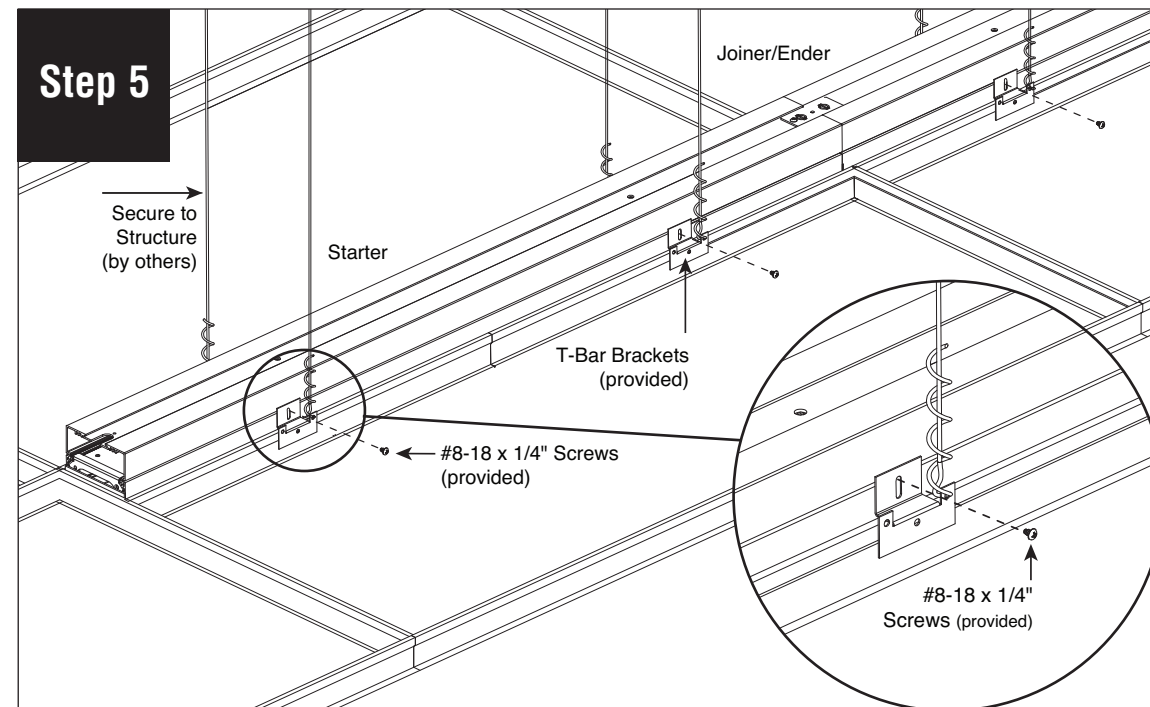

Use #8-18 x 1/4" screws (provided) to install brackets on luminaires. Secure all luminaires to building structure using tie-wire, as per code

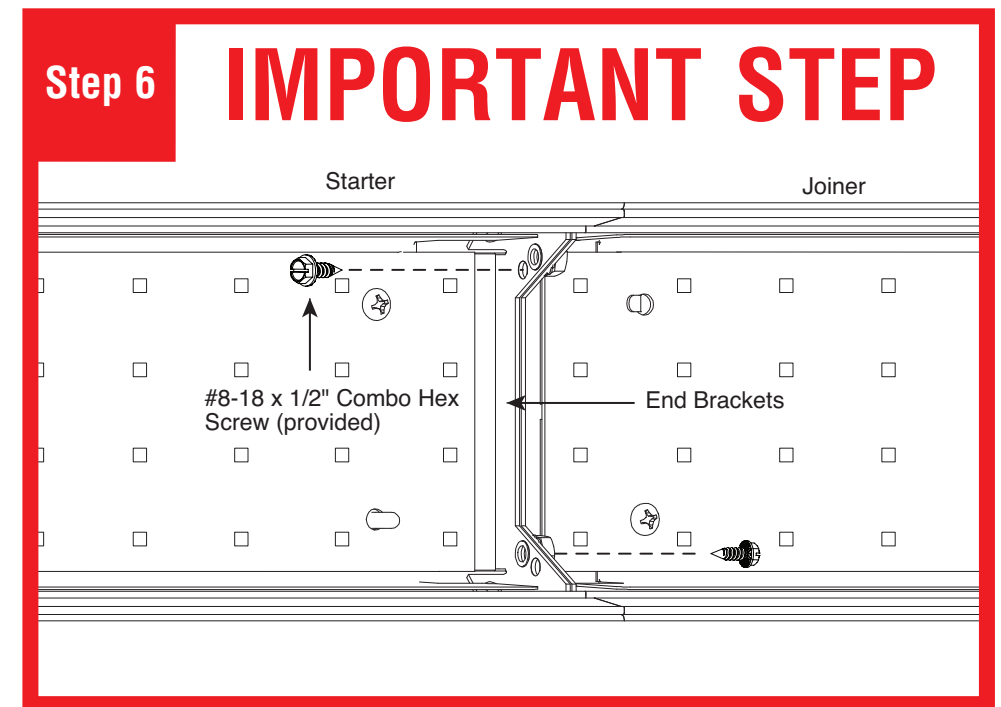

**IMPORTANT STEP:** Install the two #8-18 x 1/2" combo hex screws (provided) into end bracket as shown. Screws can be installed from the left or right. When installed correctly these hex screws will pull luminaires together to make a tight joint. **CAUTION: Do not over-tighten.**

**Note:** All power connections to be installed to local/national codes by a Certified Electrician.

# HP-4 Recessed Flush Diffuser 1" Tegular Joiner/Ender Installation Instructions

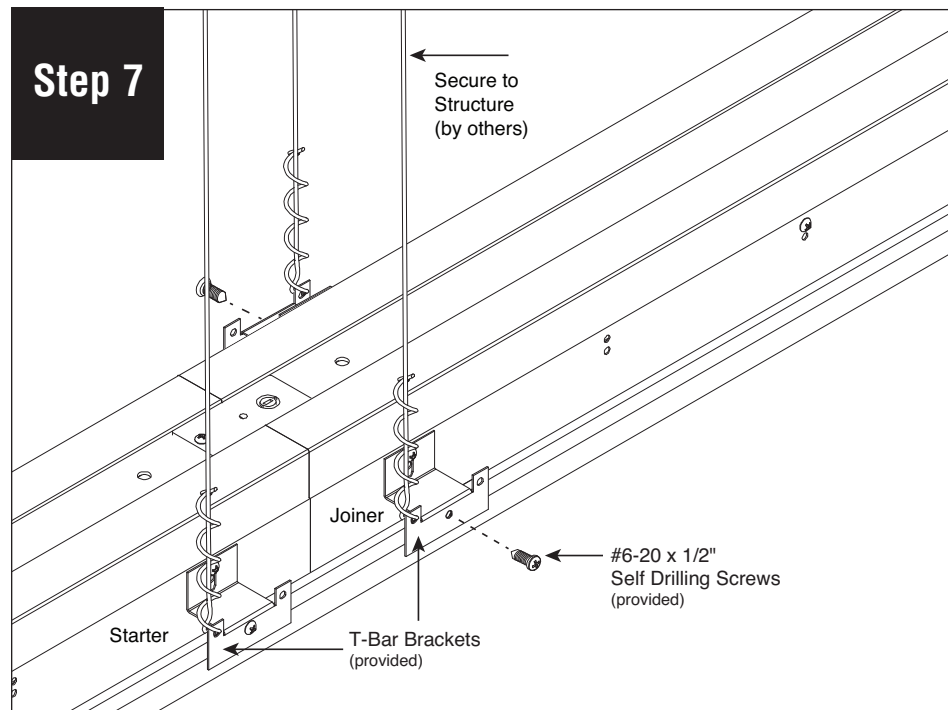

Secure luminaire to T-Bar by driving #6-20 x 1/2" self drilling screws (provided) through the T-Bar brackets (provided) into the T-Bar.

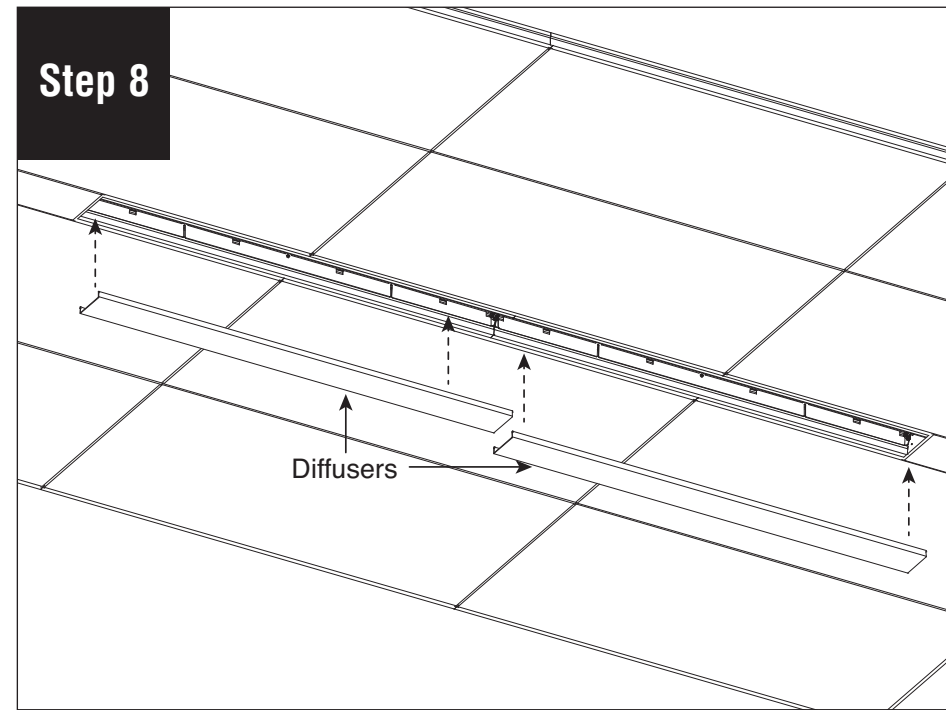

Reinstall diffuser and turn power on to luminaire. **NOTE:** If part of a longer run, diffuser will be reinstalled back into original luminaire section as lengths vary.

**Note:** All power connections to be installed to local/national codes by a Certified Electrician.