

# HP-2 Recessed 1" T-Bar to Visible Flange Installation Instructions

Scan QR code for helpful video(s)

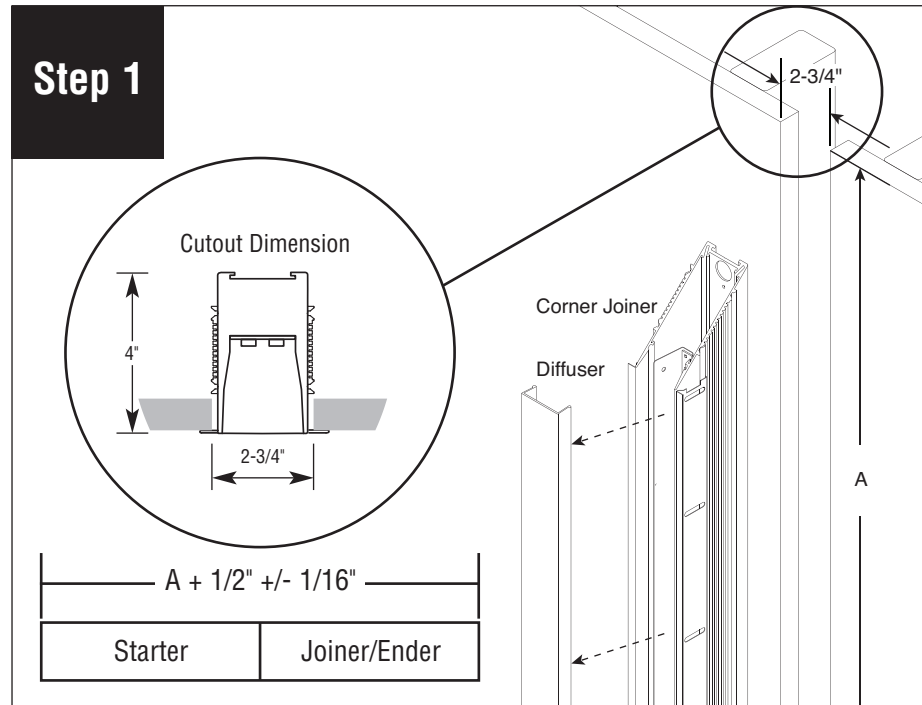

0 - 10V Dimming



Remove diffuser from corner joiner luminaire and set aside to prevent it from getting dirty or damaged. Add 1/2" to body/row length (A), +/- 1/16" to simplify installation. Luminaire needs to be installed next to support blocking.

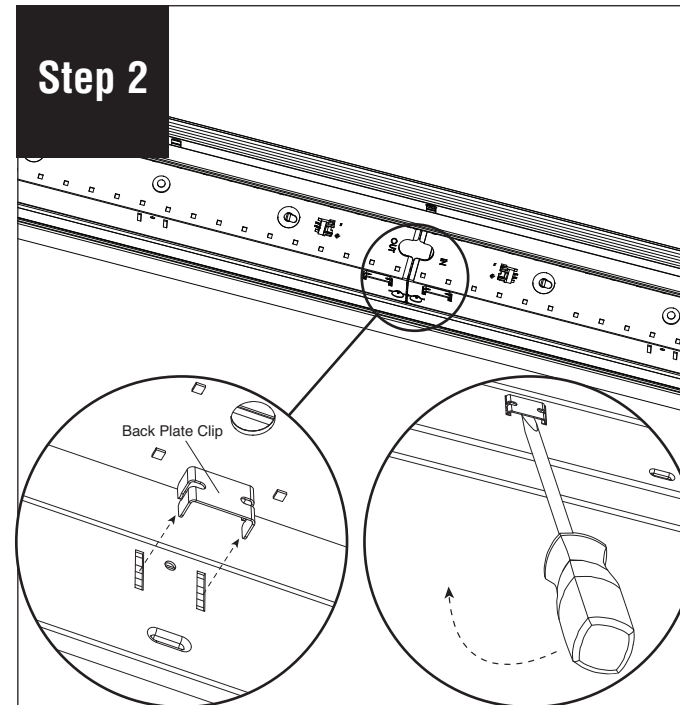

Remove back plate clips (provided) to release back plates. We recommend using a flat head screwdriver to get them loose. **CAUTION: Do not lose these pieces.**

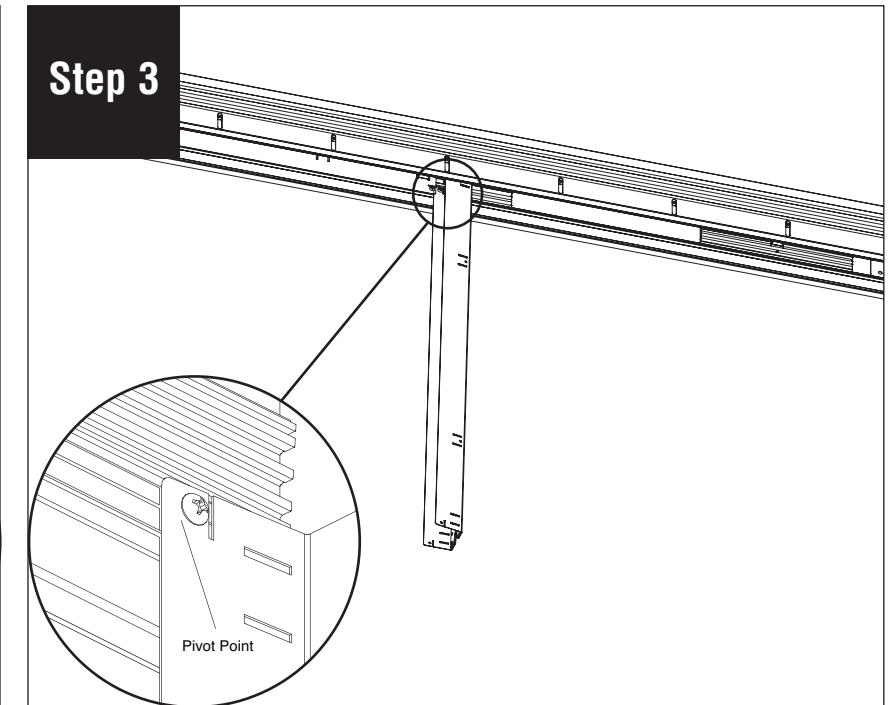

Slowly swing down back plates from all luminaires. **CAUTION: Do not twist back plate when swinging down - it will come out of the support extrusion.** Note that the screw shown is the pivot point and the back plate can be slid a few inches either way for ease of access to the driver space.

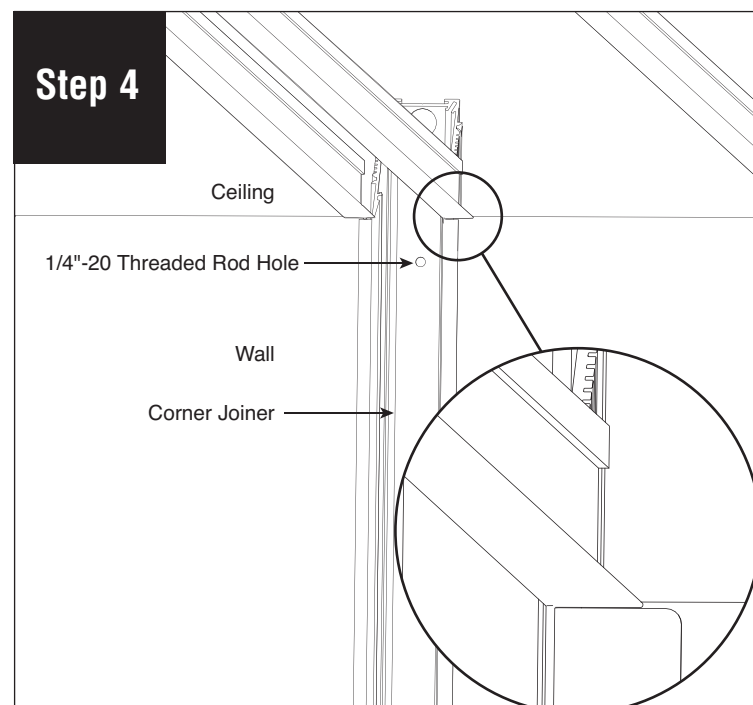

Make sure visible flange is flush with ceiling T-Bar.

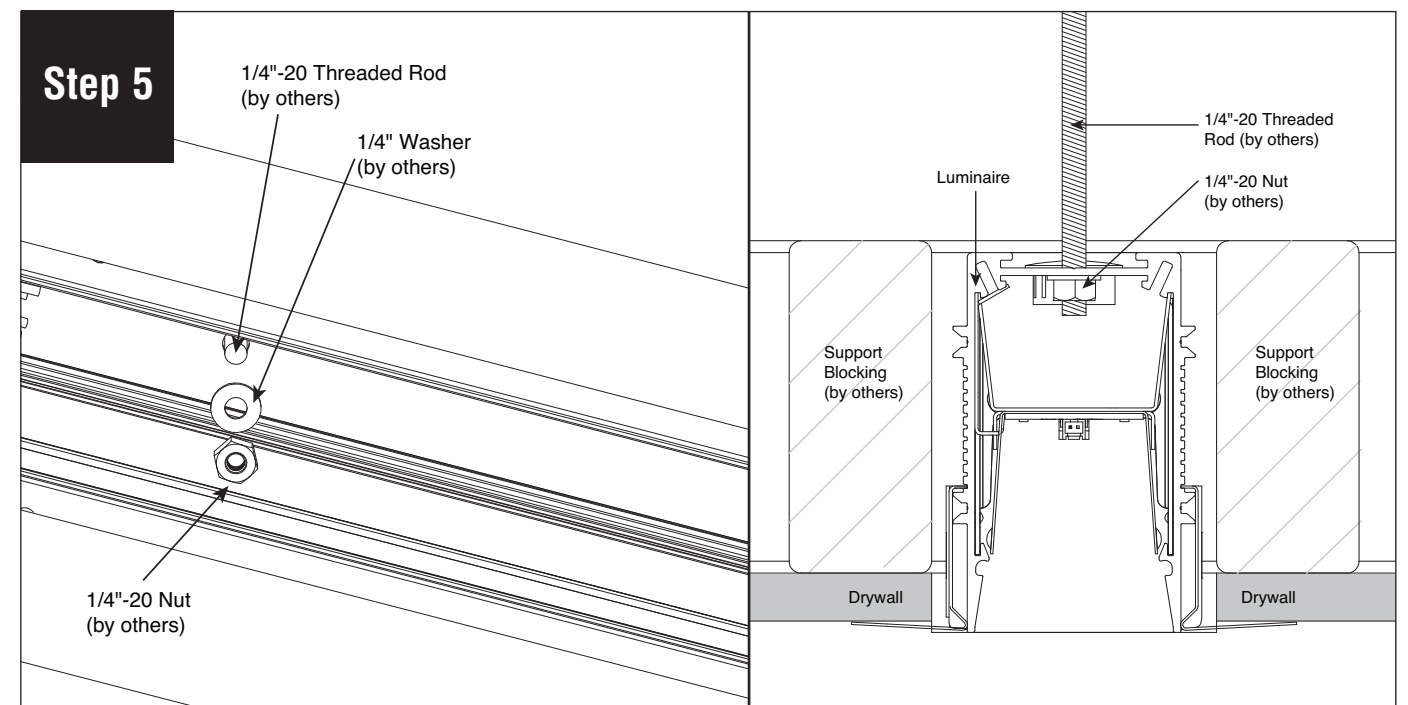
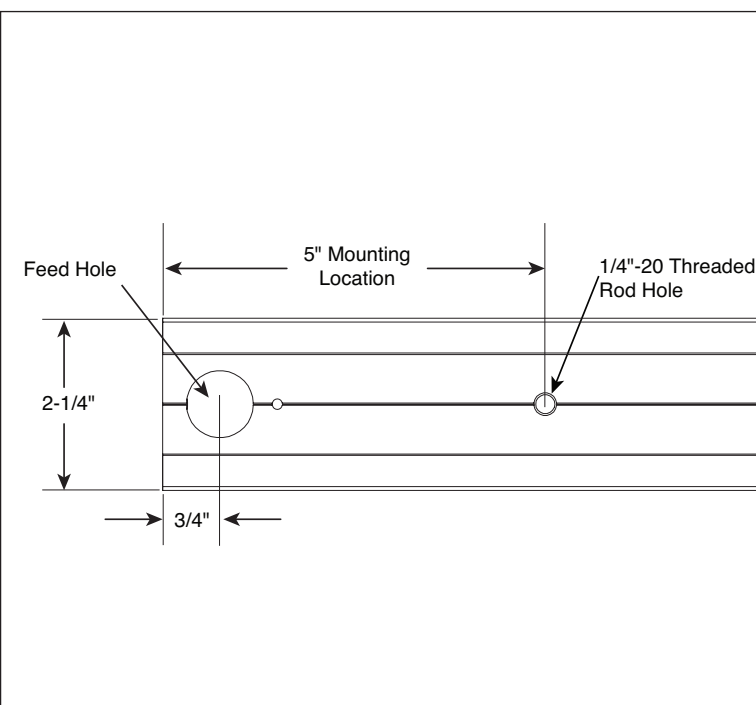

A. Secure corner joiner by installing 1/4" washers (by others) and 1/4"-20 nuts (by others) onto 1/4"-20 threaded rod (by others).

**Note:** All power connections to be installed to local/national codes by a Certified Electrician.

# HP-2 Recessed 1" T-Bar to Visible Flange Installation Instructions

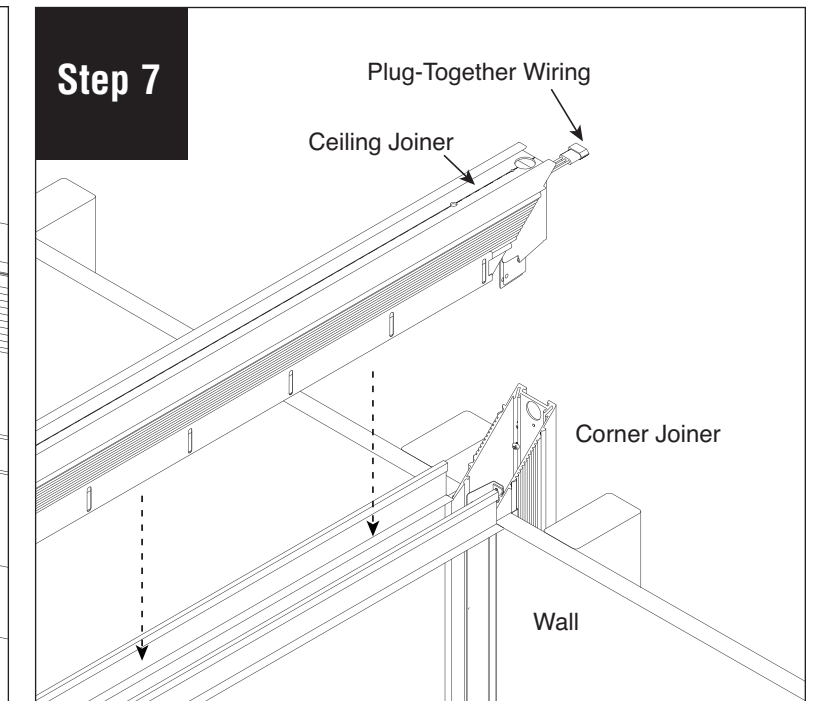
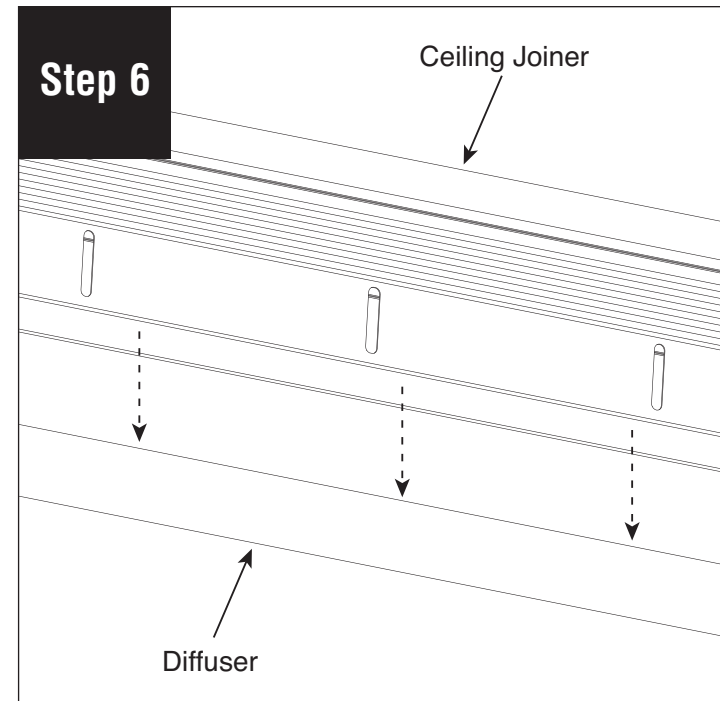
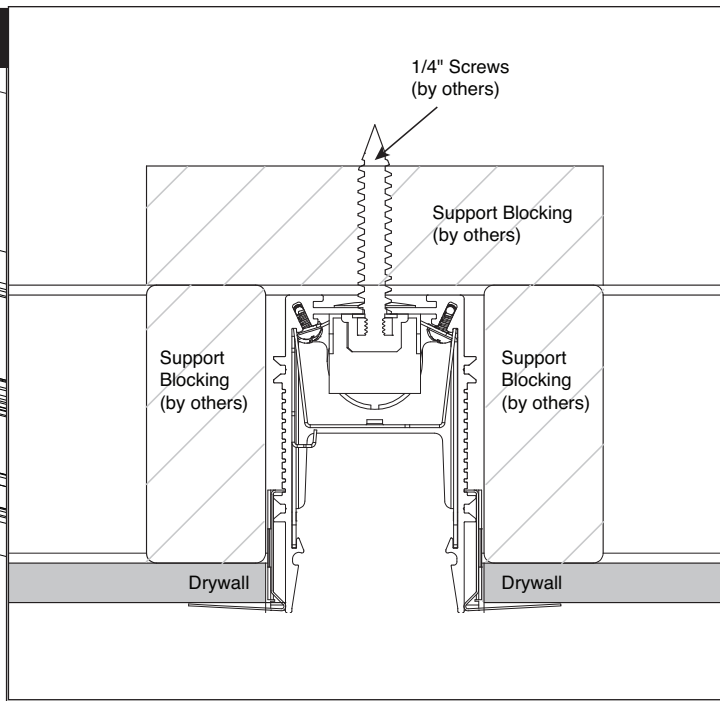
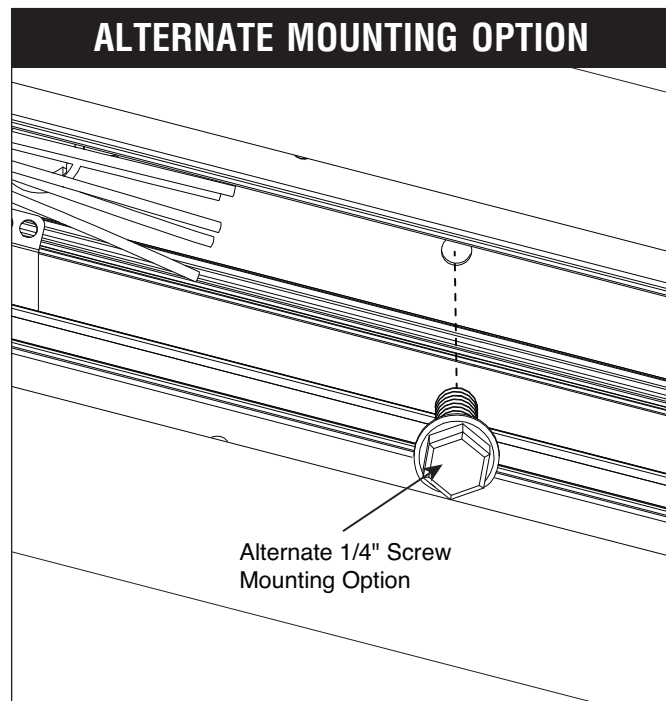

**B.** Alternate mounting option – Install 1/4" screw (by others) through mounting hole into proper structurally supported blocking (by others).

Remove diffuser from recessed 1" T-Bar joinder luminaire and set aside to prevent it from getting dirty or damaged.

Place joinder luminaire on T-Bar.

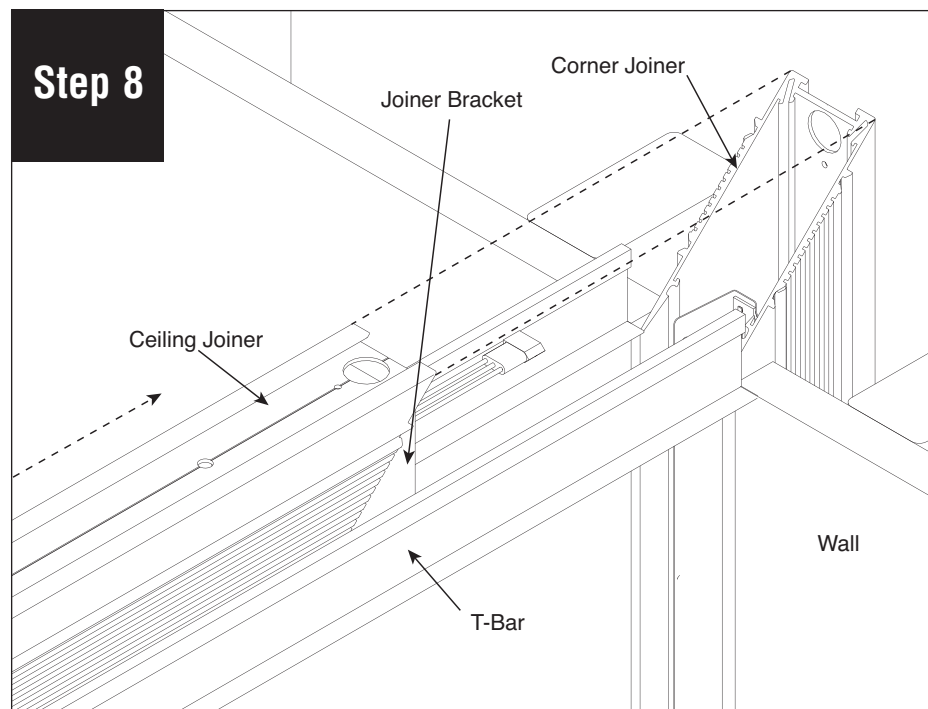

Align joinder bracket with corner joinder. Slide ceiling joinder towards corner joinder.

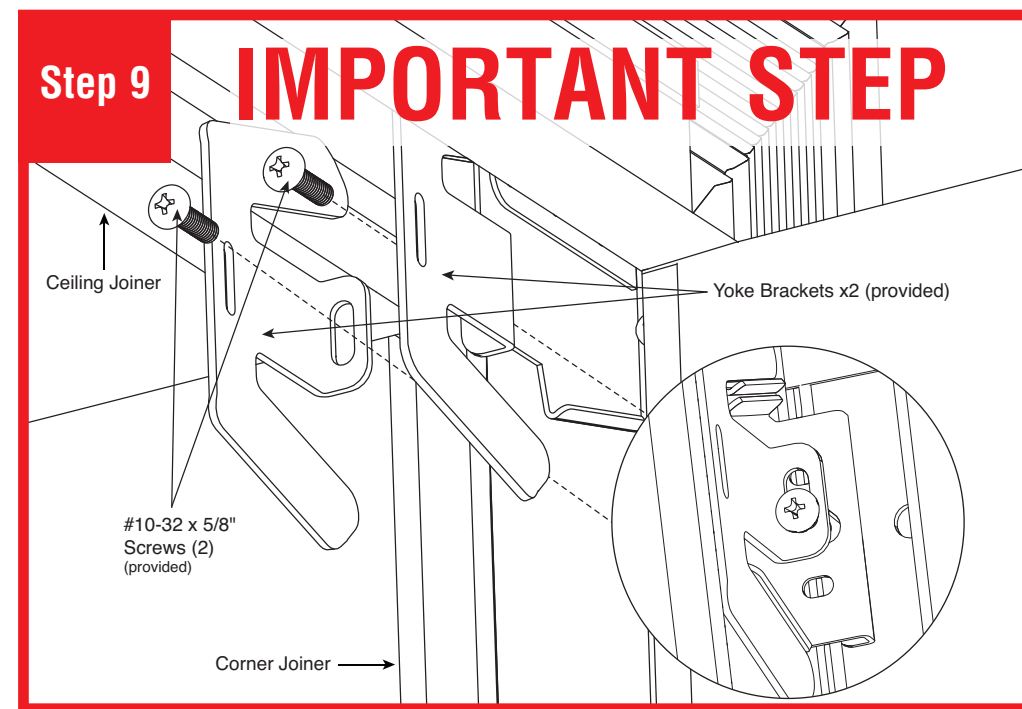

**IMPORTANT STEP:** Secure joint with two yoke brackets (provided) using #10-32 x 5/8" screws (provided). **CAUTION:** When installed correctly these brackets will pull luminaires together to make a tight joint. Do not over-tighten.

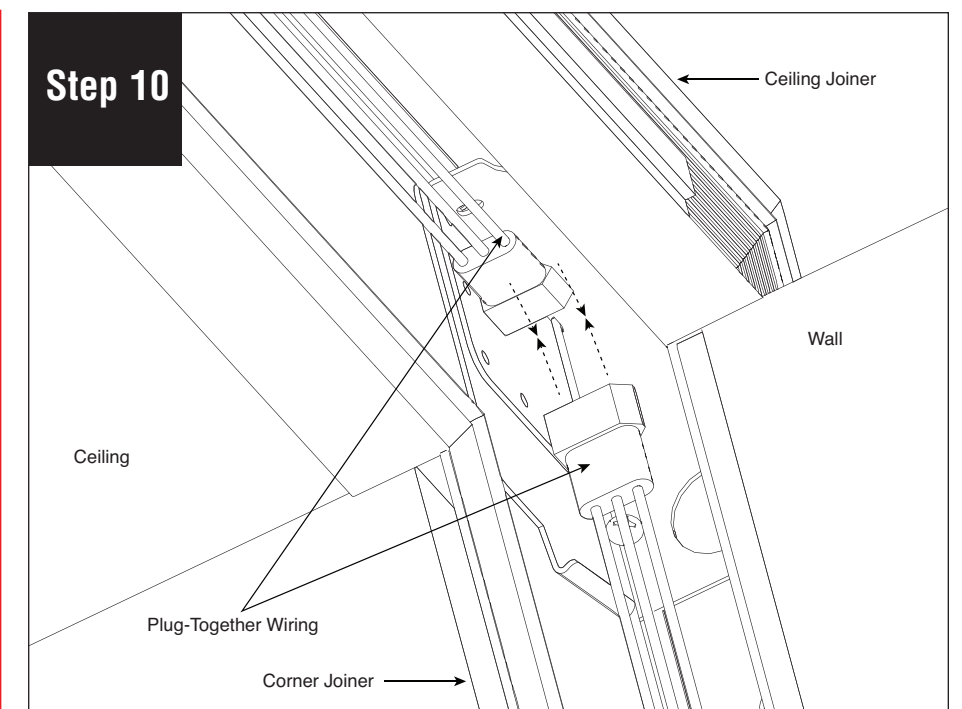

Connect plug-together wiring.

**Note:** All power connections to be installed to local/national codes by a Certified Electrician.

# HP-2 Recessed 1" T-Bar to Visible Flange Installation Instructions

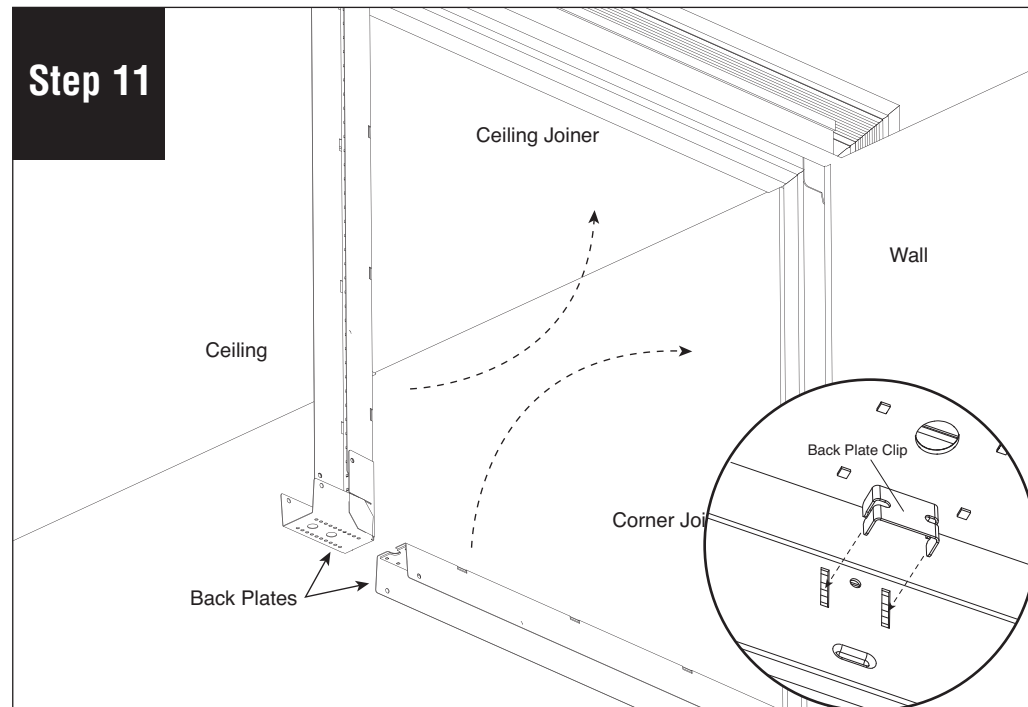

Replace all back plates by holding them in their original position and pushing the clips back in. Make sure wire connections are not pinched. (If 1 ft. back plate assembly is near joint, reconnect feed harness to LED board.

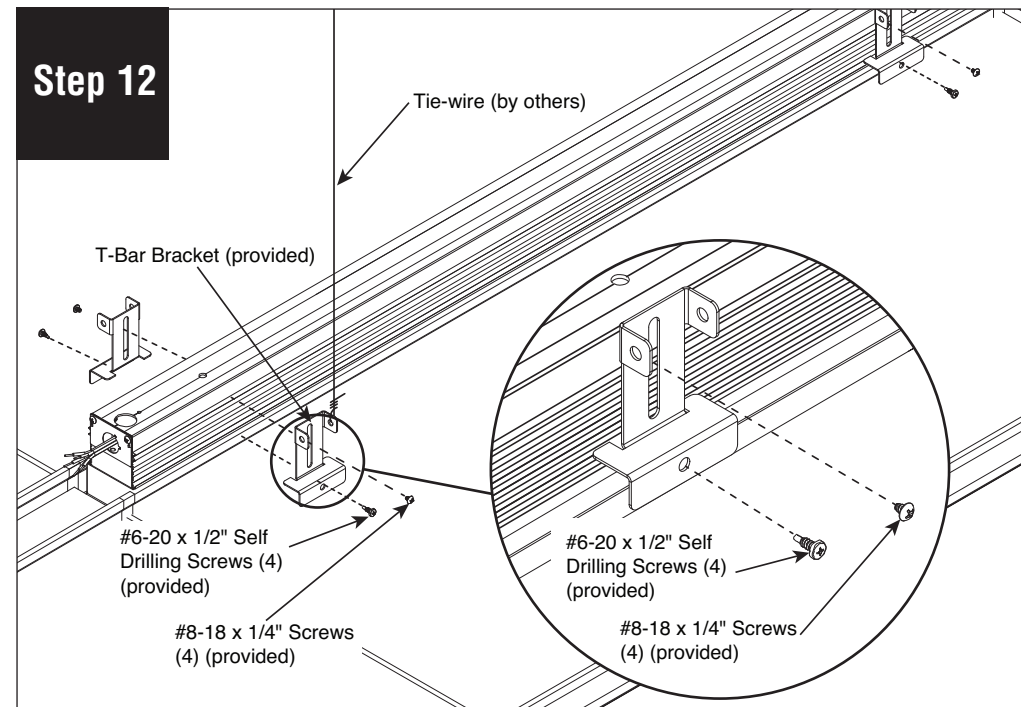

Install T-Bar brackets (provided) onto ceiling joiner with #8-18 x 1/4" screws (provided). Secure luminaire to T-Bar with #6-20 x 1/2" self drilling screw (provided). Secure luminaire to structure using tie-wire (by others), as per code.

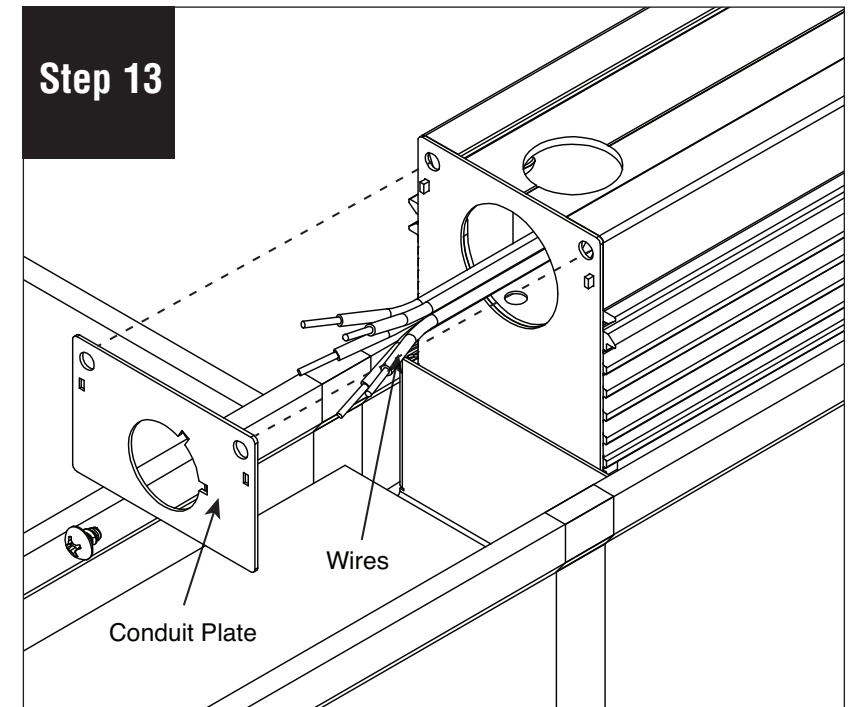

Remove conduit plate from ceiling joiner luminaire.

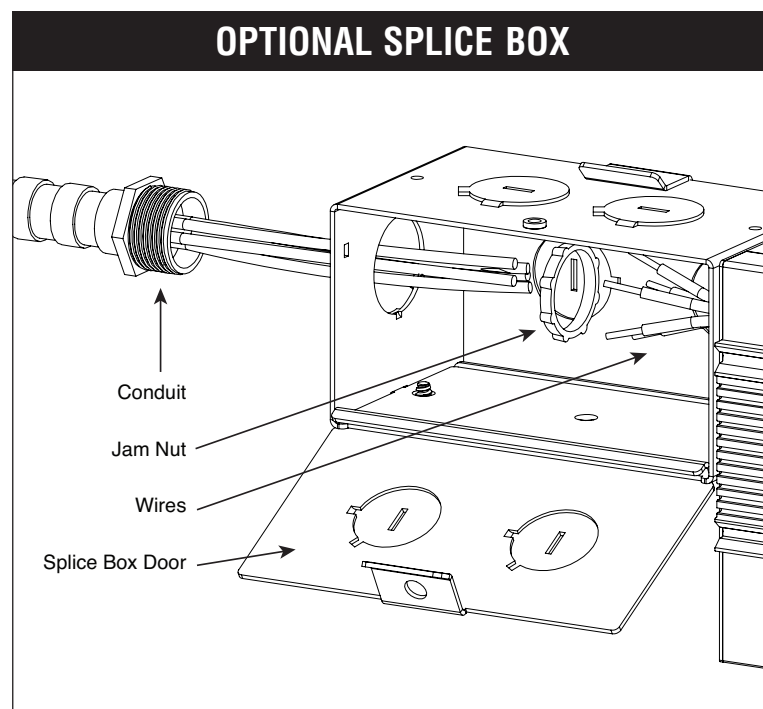

Open optional splice box door to access wiring.

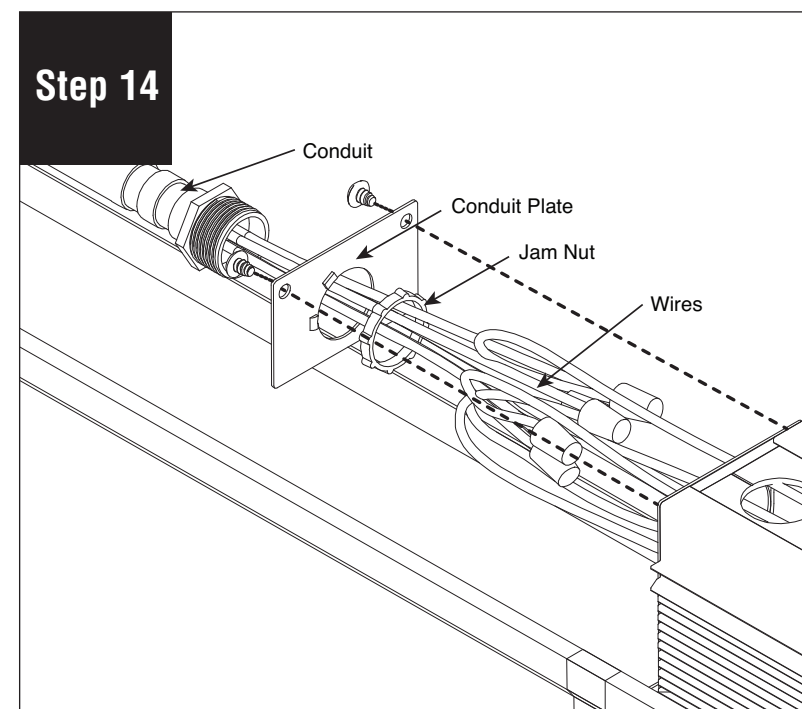

Run power cables through conduit plate and jam nut. Make electrical connections. Secure conduit onto conduit plate with jam nut, and reinstall conduit plate carefully not to damage any wiring.

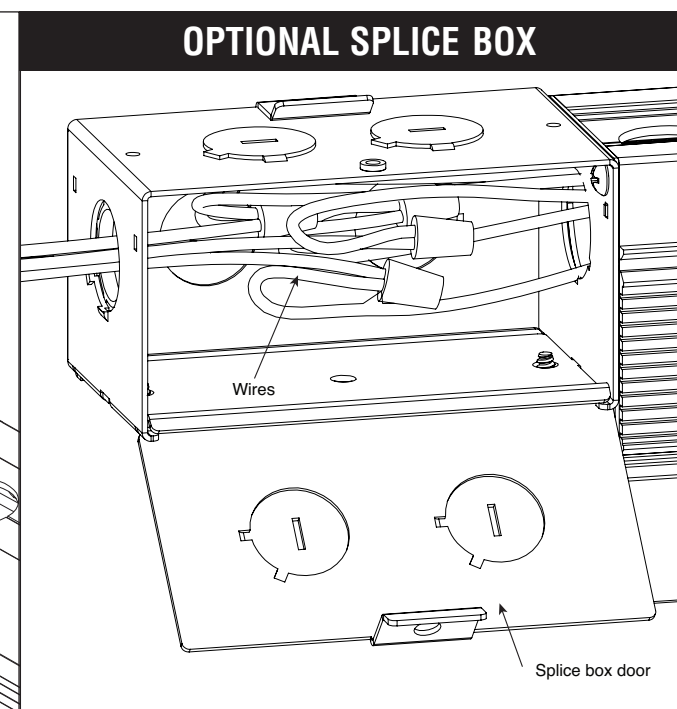

Run power cable through knock-out. Make electrical connections. Secure conduit on to splice box with jam nut and close splice box door.

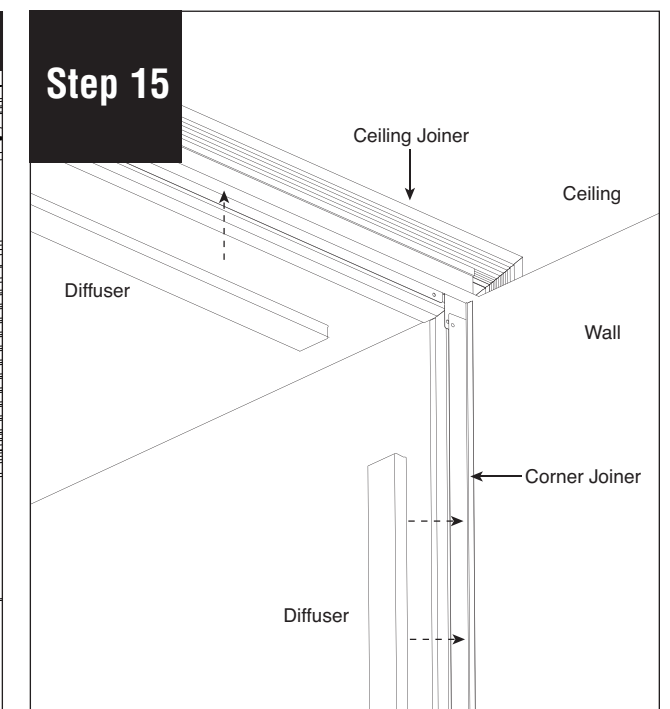

Replace diffusers and turn power on to luminaires.

**Note:** All power connections to be installed to local/national codes by a Certified Electrician.