

# HP-2 Direct Mitered Corner Installation Instructions

Scan QR code for helpful video(s)

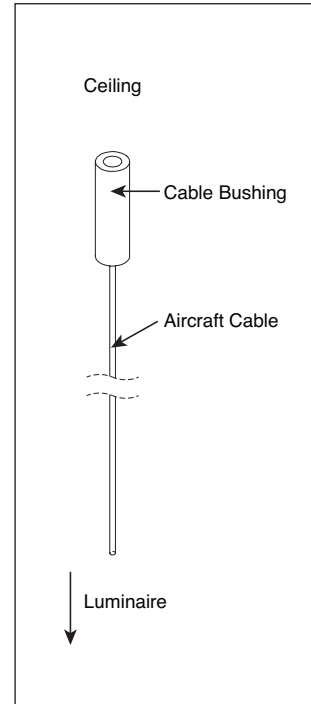

0 - 10V Dimming



Locate aircraft cables.

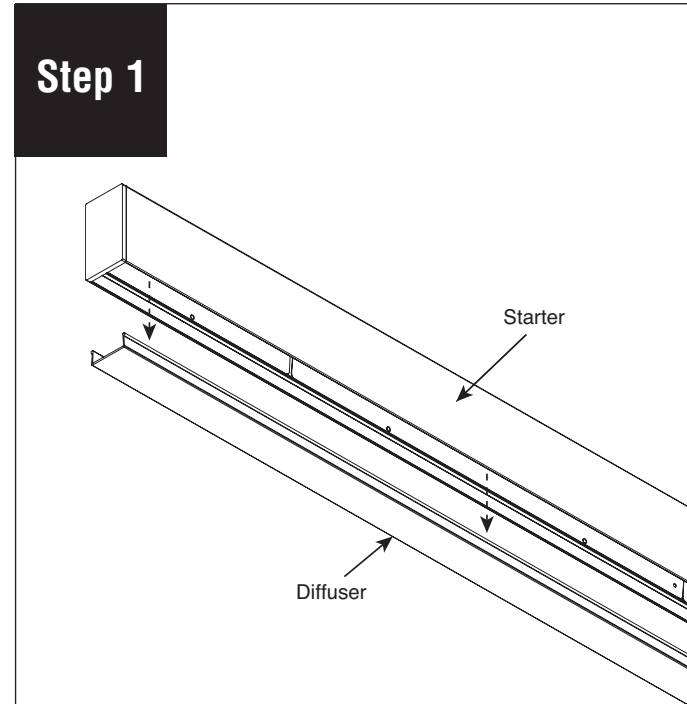

Remove diffuser from starter and set aside to prevent it from getting dirty or damaged.

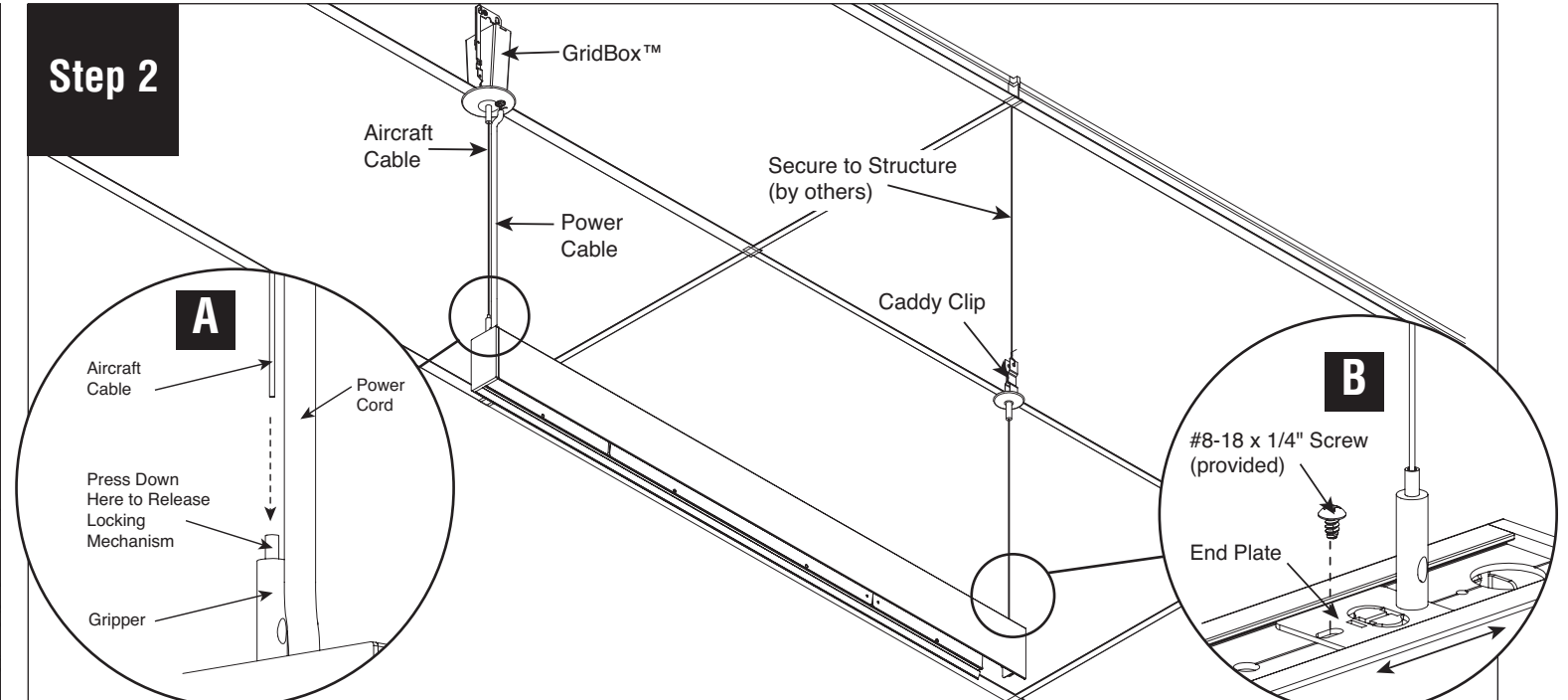

Install GridBox™ and caddy clip onto ceiling grid, then canopies and aircraft cable assemblies. **A.** Align aircraft cables to grippers and insert on both ends of the luminaire. Adjust pendant to proper height and level. Press down on top of gripper to release locking mechanism if needed. Secure luminaire to structure using tie-wire (by others) according to code. **B.** End plates are adjustable for custom mounting locations. Remove #8-18 x 1/4" screw (provided) from end plate, then slide end plate to desired location and reinstall #8-18 x 1/4" screw.

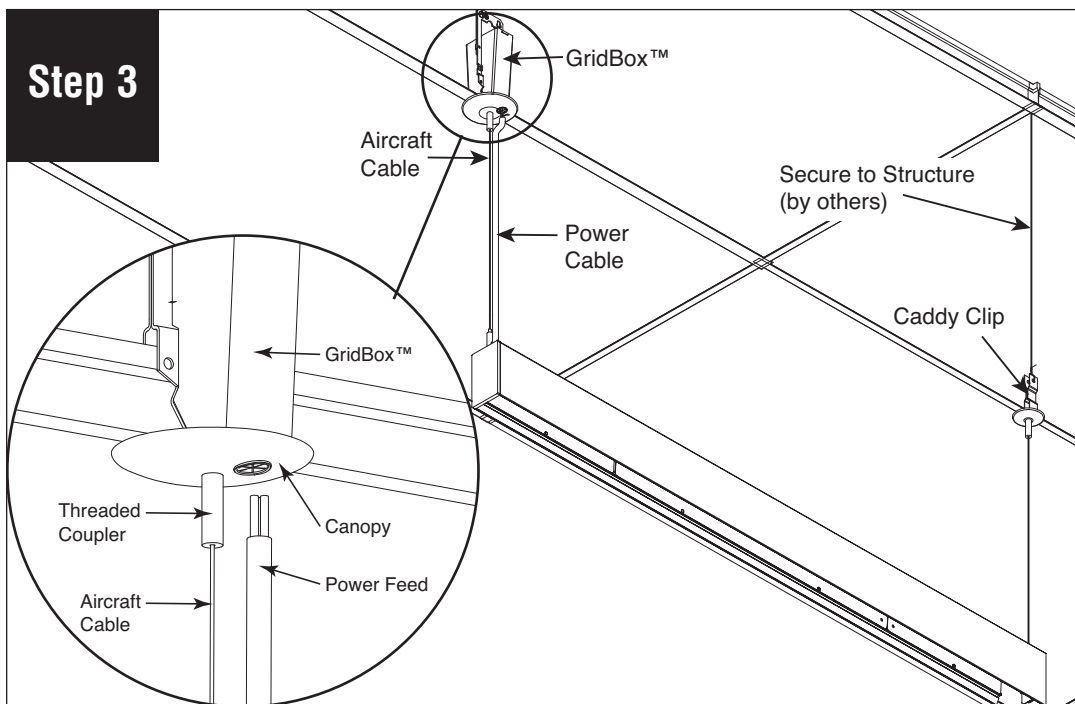

Install power cable through canopy and into GridBox™. Make electrical connections in GridBox.

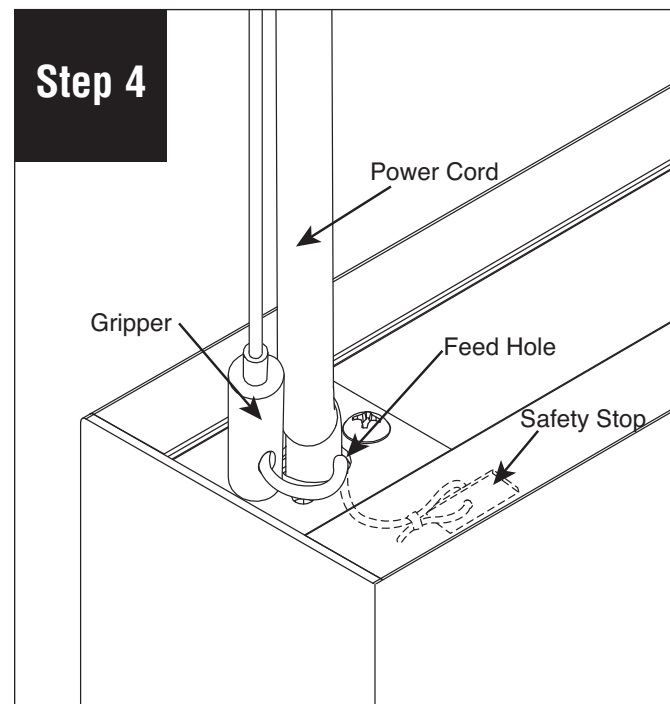

Slide safety stop and safety crimp up to the aircraft cable within 9" of cable gripper. Trim excess cable and insert safety bar assembly through feed hole.

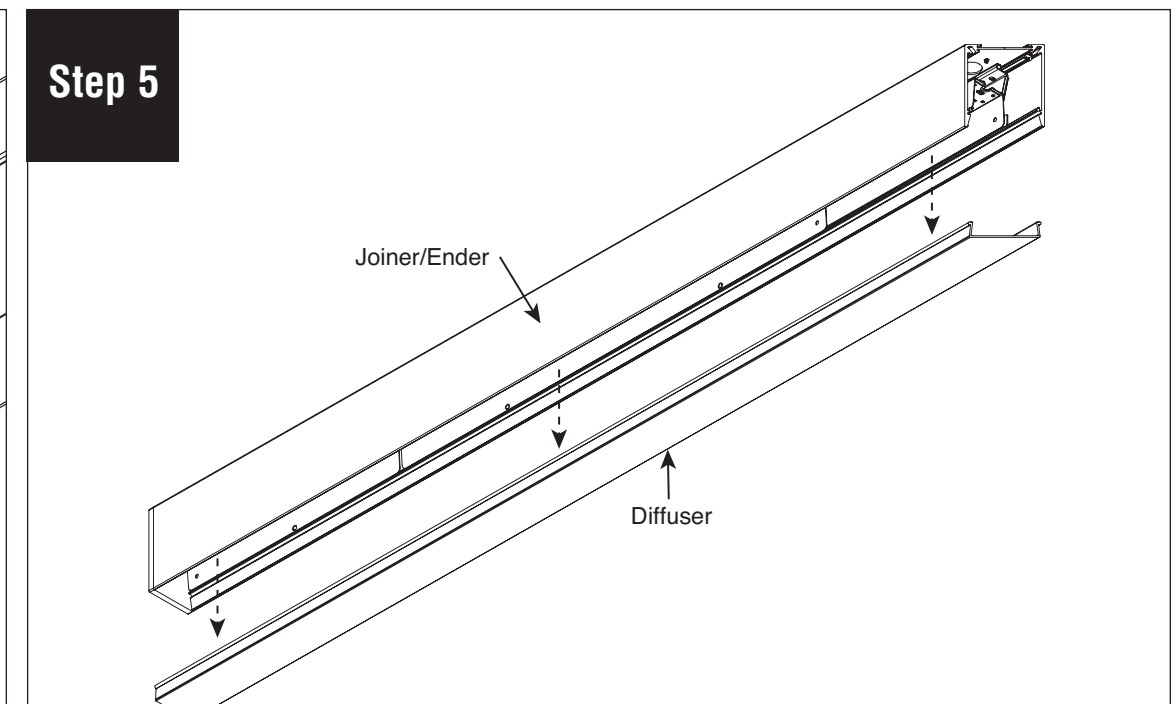

Remove diffuser from joiner/ender and set aside to prevent it from getting dirty or damaged.

**Note:** All power connections to be installed to local/national codes by a Certified Electrician.

# HP-2 Direct Mitered Corner Installation Instructions

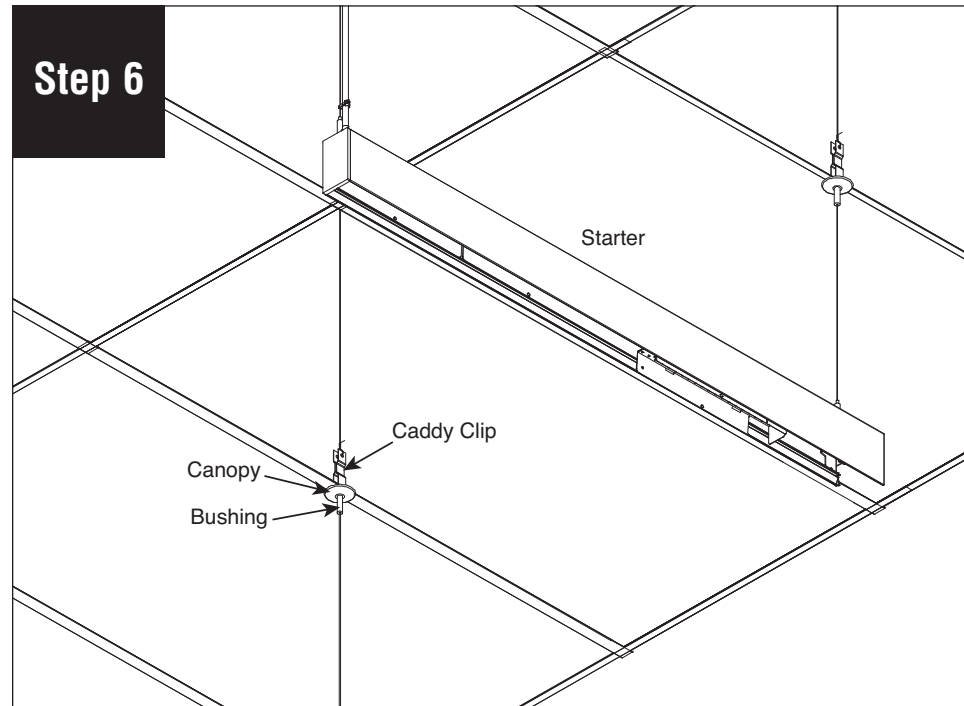

Install caddy clip for joiner/ender.

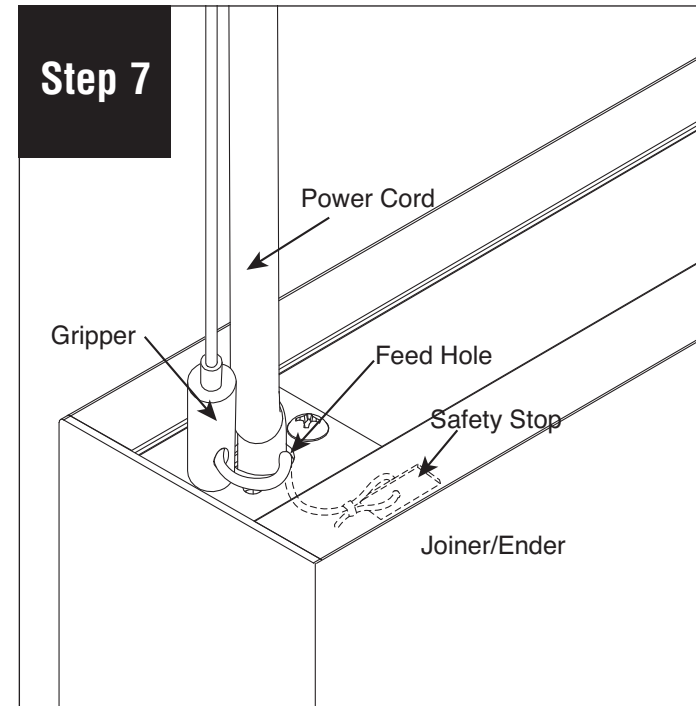

Slide safety stop and safety crimp up to the aircraft cable within 9" of cable gripper. Trim excess cable and insert safety bar assembly through feed hole.

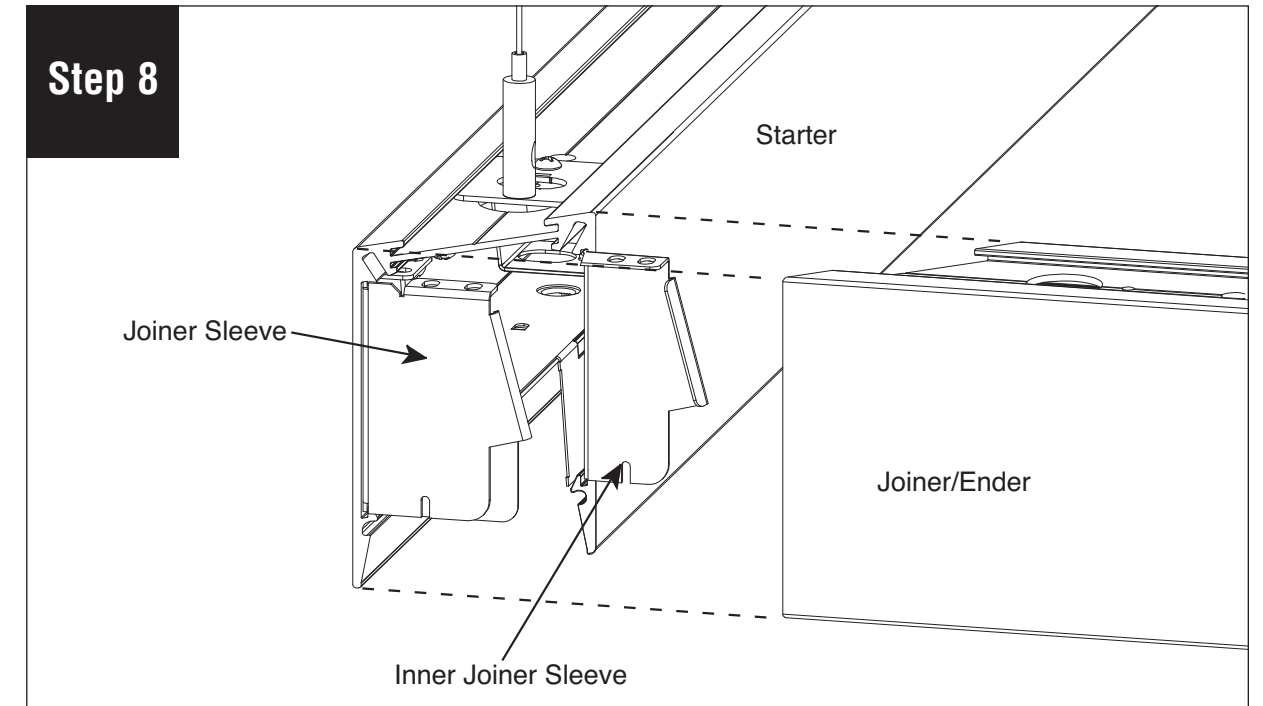

Align starter and joiner/ender, then slide luminaires together.

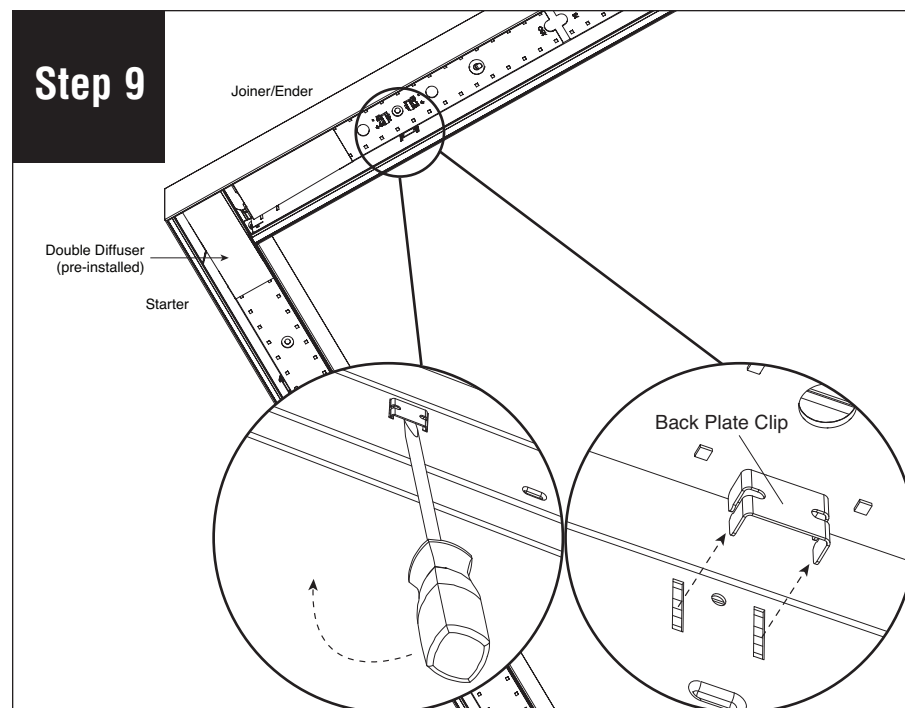

Remove back plate clips (provided) to release back plates. We recommend using a flat head screwdriver to get them loose. **CAUTION: Do not lose these pieces.**

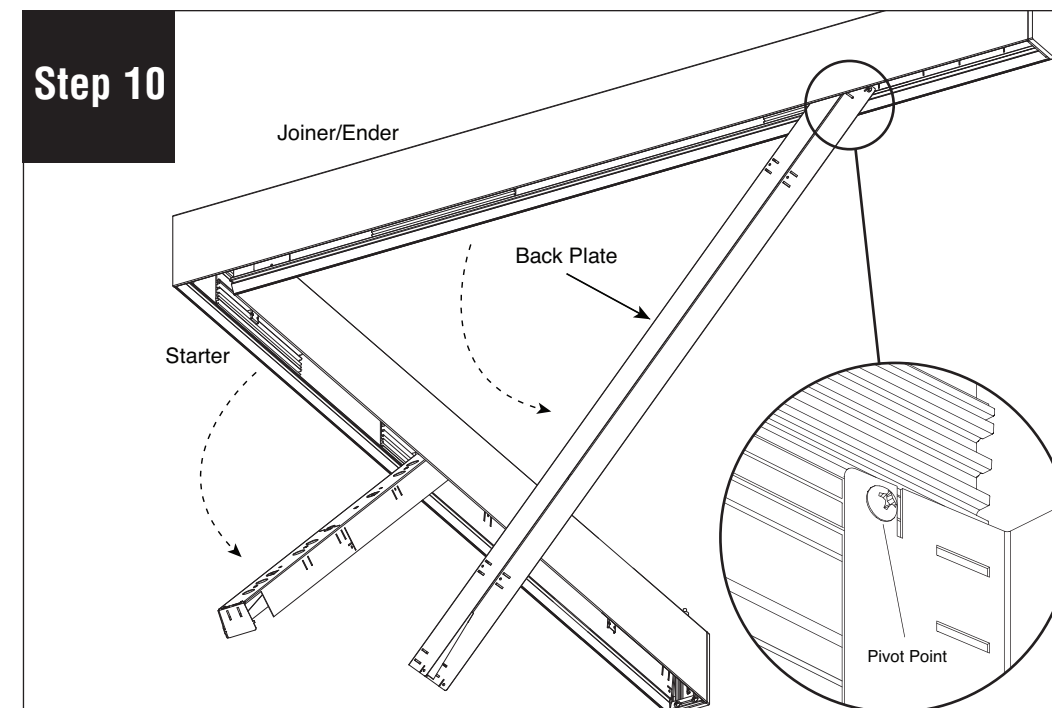

Slowly swing down back plates. **CAUTION: Do not twist back plate when swinging down – it will come out of the support extrusion.** Note that the screw shown is the pivot point and the back plate can be slid a few inches either way for ease of access to the driver space.

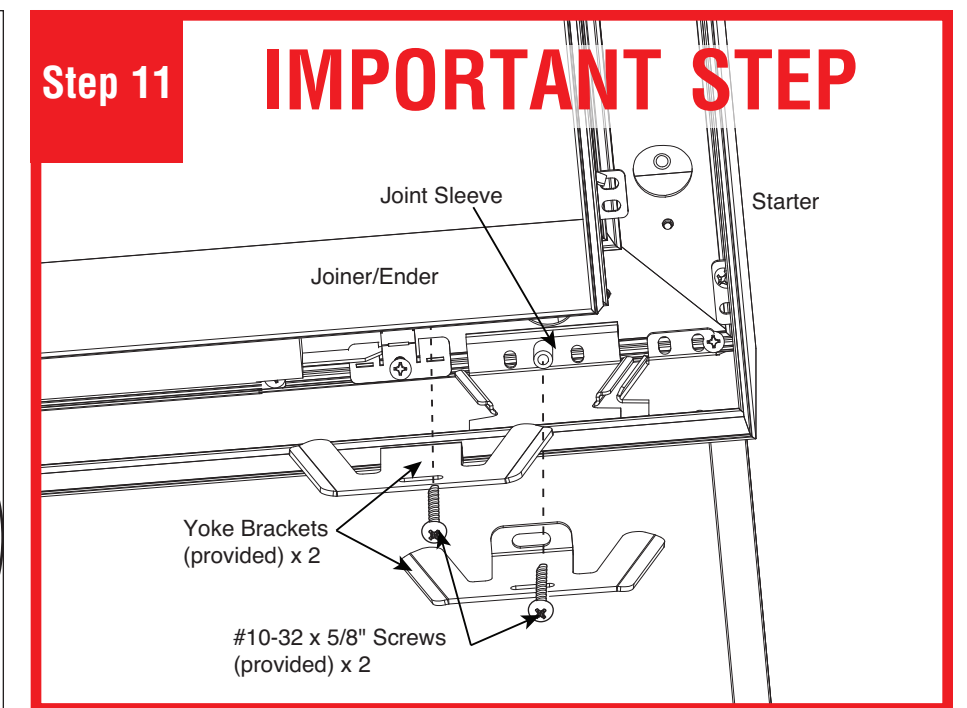

**IMPORTANT STEP:** Secure joint with two yoke brackets (provided) using #10-32 x 5/8" screws (provided). **CAUTION:** When installed correctly these brackets will pull luminaires together to make a tight joint. Do not over-tighten.

**Note:** All power connections to be installed to local/national codes by a Certified Electrician.

# HP-2 Direct Mitered Corner Installation Instructions

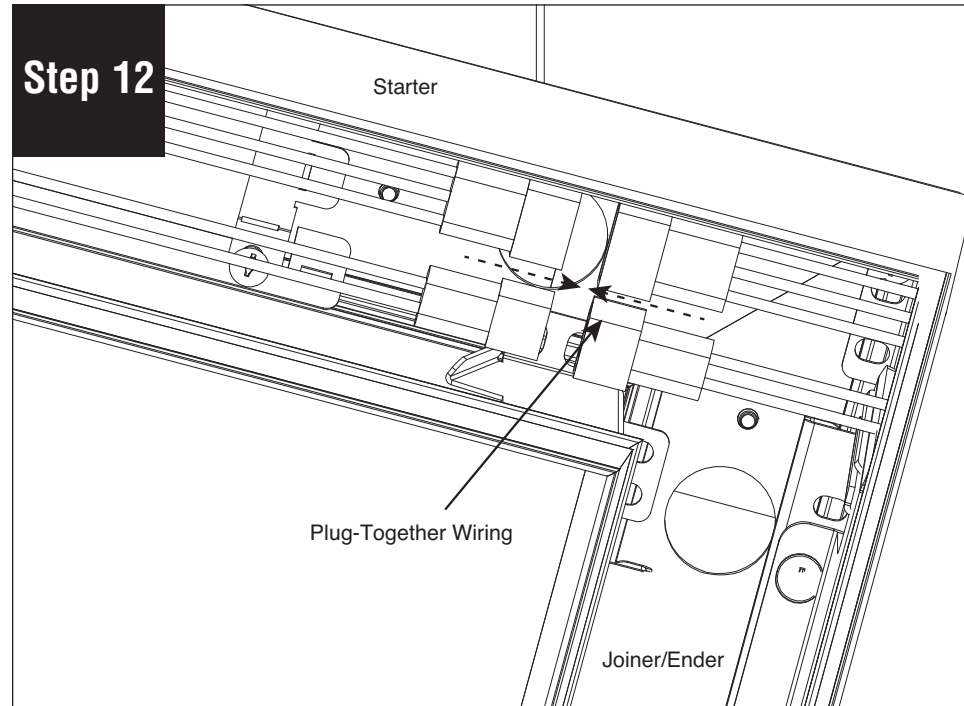

Connect plug-together wiring.

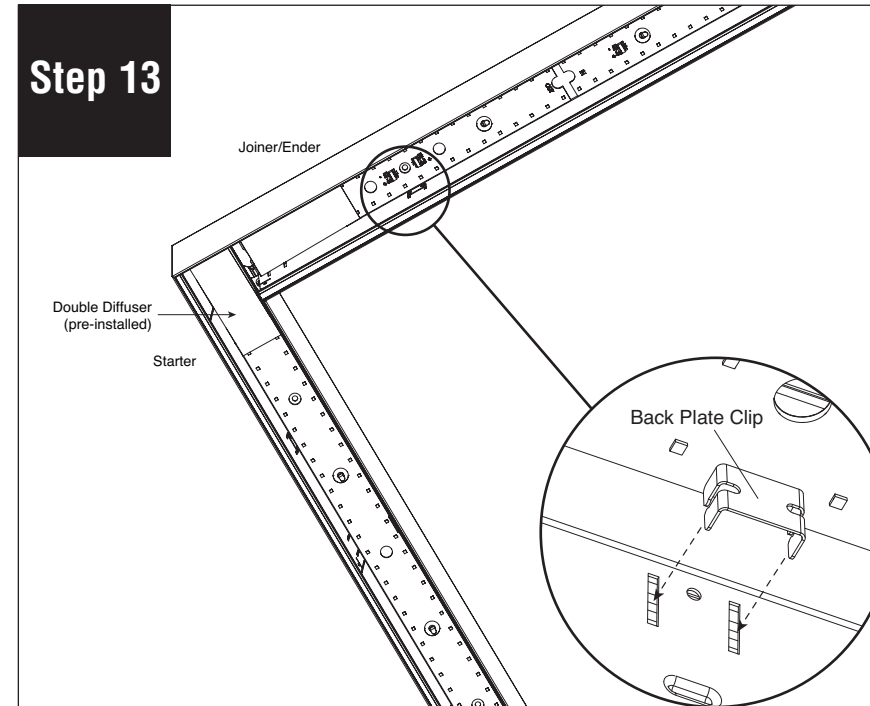

Replace back plates by holding them in their original position and pushing the clips back in. Make sure wire connections are not pinched. (If 1 ft. back plate assembly is near joint, reconnect feed harness to LED board).

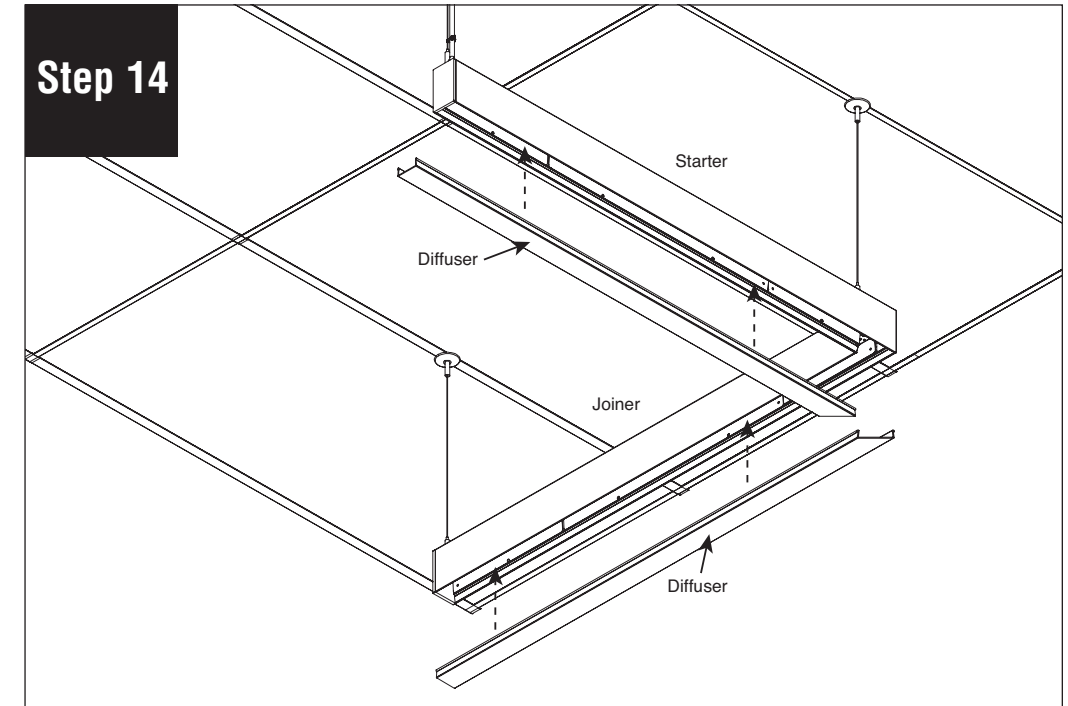

Reinstall diffuser and turn power on to luminaire.

**Note:** All power connections to be installed to local/national codes by a Certified Electrician.