

HP-4 Indirect

HP-4 | Recycling Luminaire Breakdown

Luminaire breaks down easily for recycling at the end of usable life*.

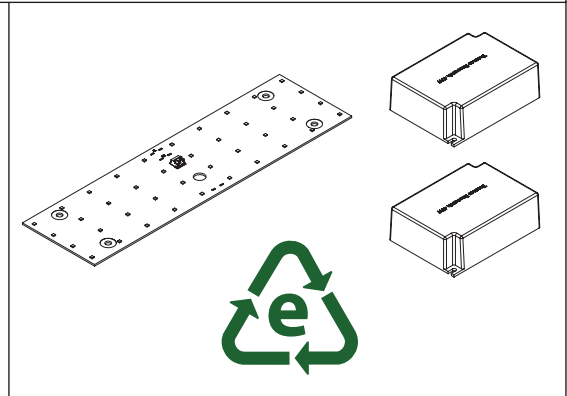
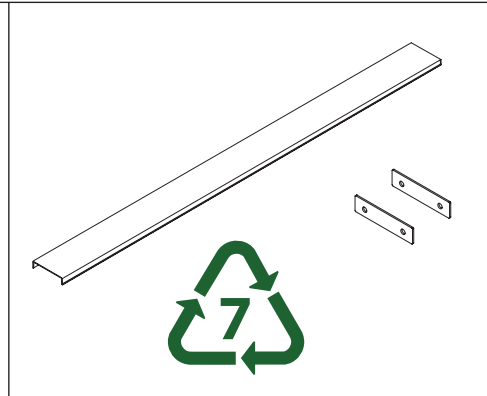
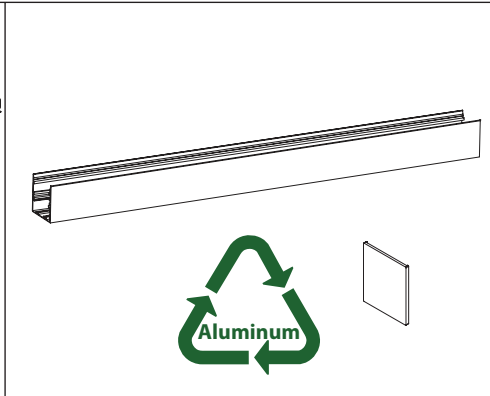
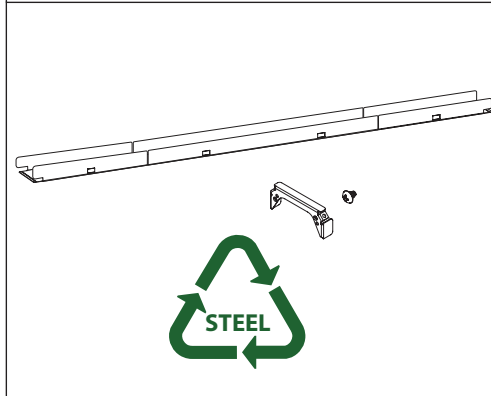
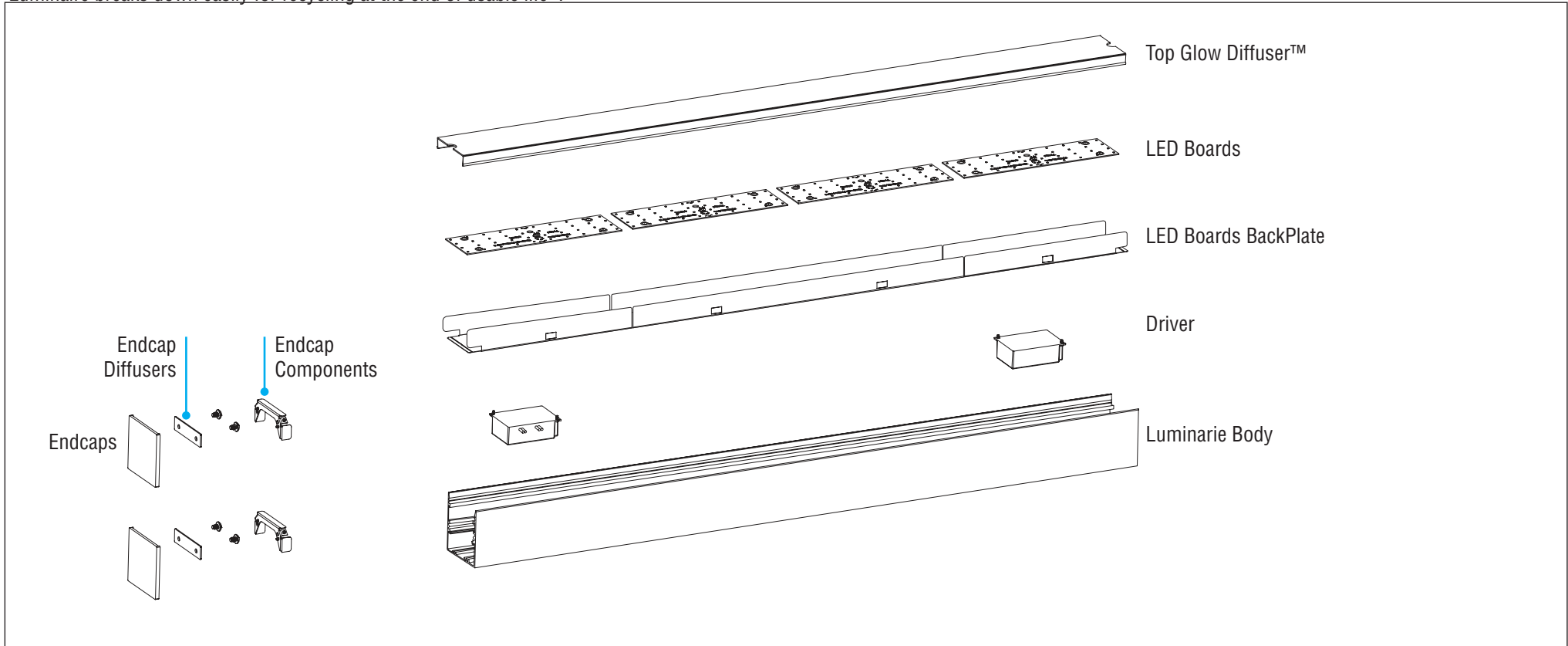

*Recycling information typical for all luminaire sizes. Contact factory for more information.

Protected by one or more US Patents: 8915613; D702,391; D702,390; D700,732

Due to continuing improvements, Finelite reserves the right to change specifications without notice. Please visit www.finelite.com for most current data.

HP-4 Indirect

HP-4 I Recycling Luminaire Breakdown

100% Recyclable

HP-4 I components are constructed from aluminum, steel, copper wire, e-waste, and plastic.
HP-4 I is 100% recyclable at the end of useful life.

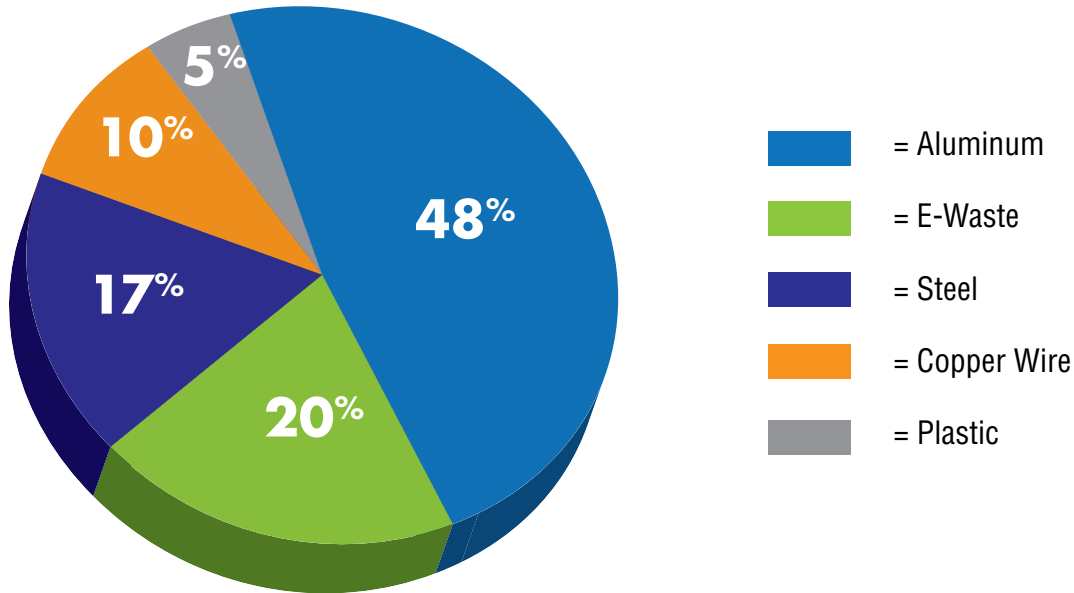

Due to continuing improvements, Finelite reserves the right to change specifications without notice. Please visit www.finelite.com for most current data.