

# S16 LED 2E Driver Replacement Installation Instructions

## Step 1

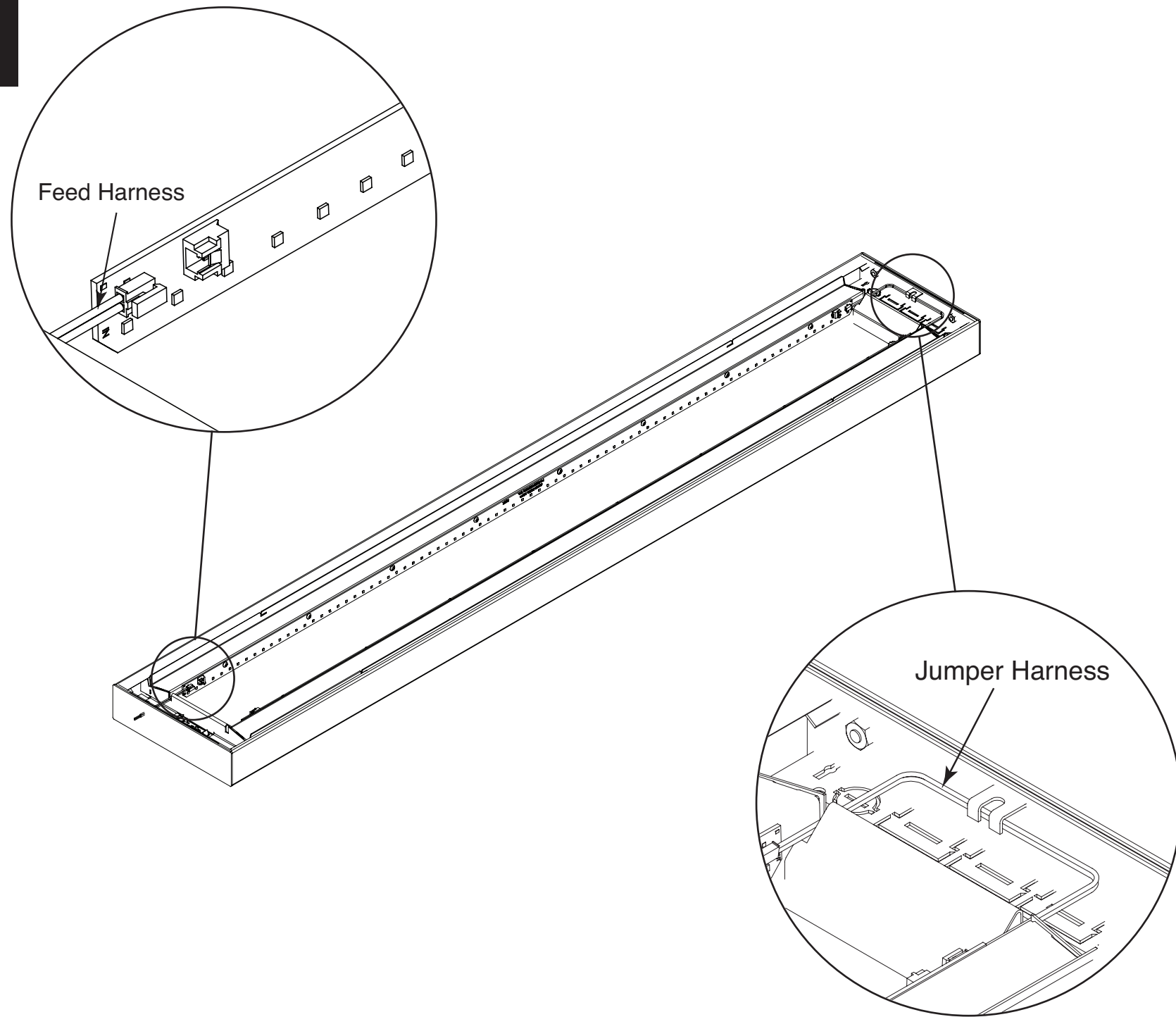

Disconnect feed harness and jumper harness.

## Step 2

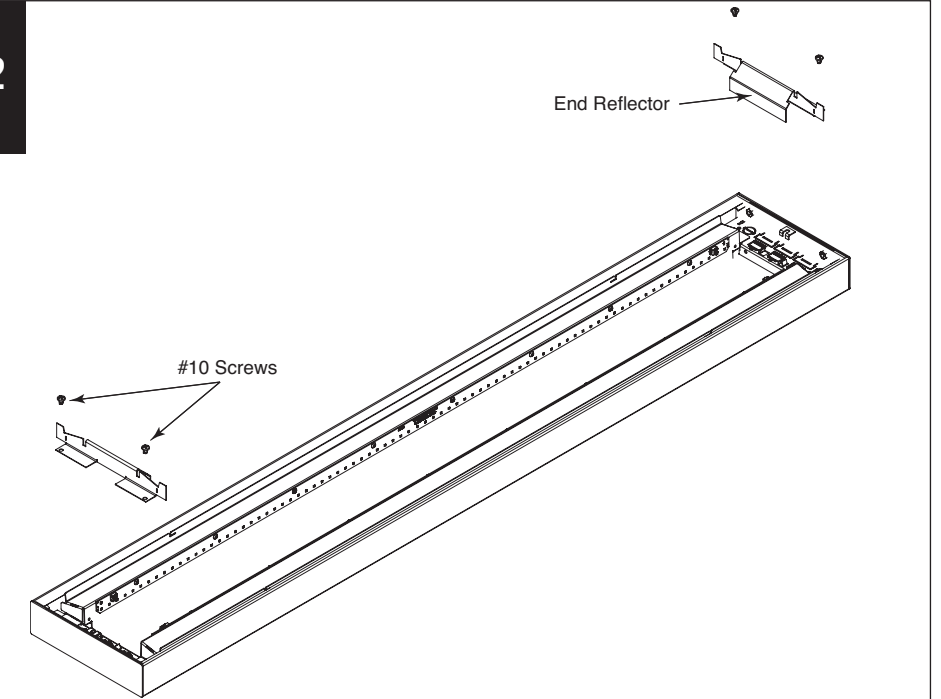

Remove #10 screws (4) on both ends of reflectors, then remove end reflectors.

## Step 3

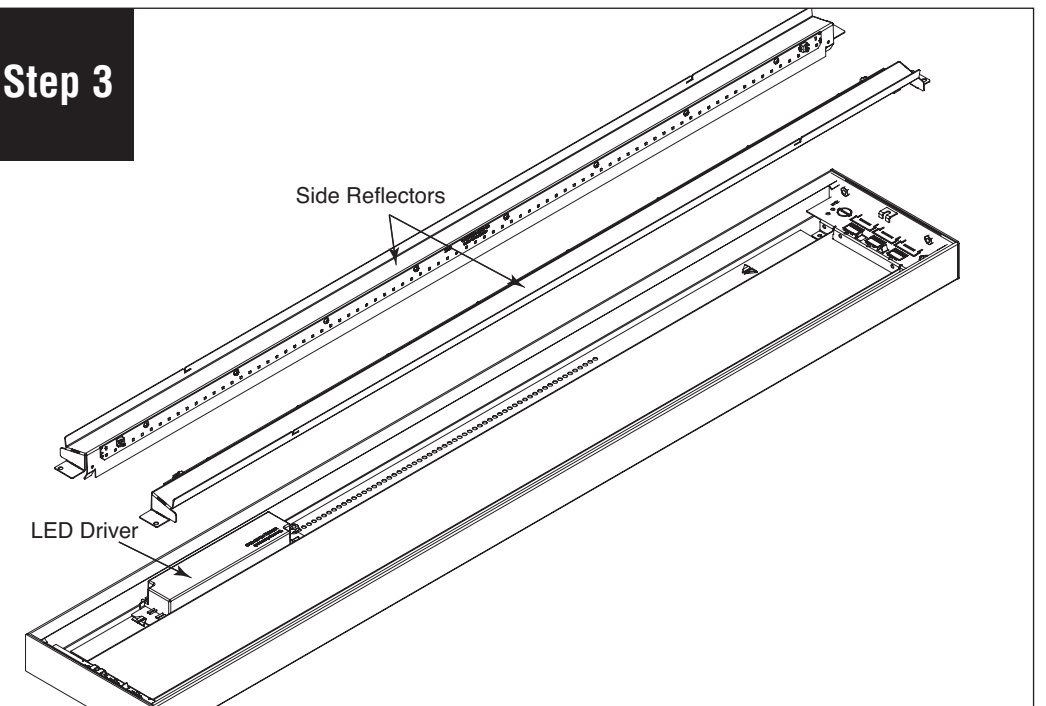

Remove side reflectors assemblies to access LED driver(s). Remove 2 #10 screws that secure the LED driver(s) and replace with new driver(s). Reverse steps to reassemble fixture.