

S12 LED Wall Mount 2E Starter/Independent Installation Instructions

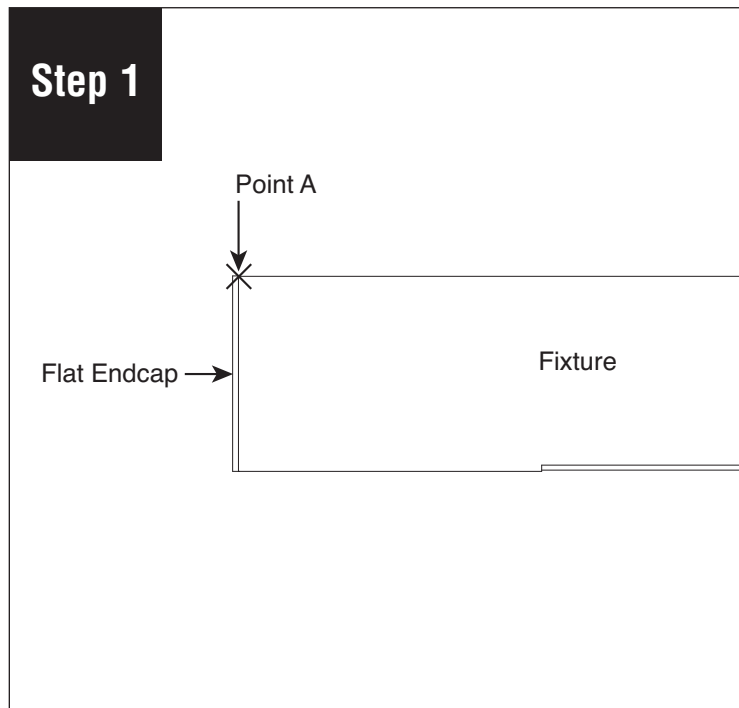

Position fixture on wall in desired location. Mark on wall the point where the end cap and the fixture body meet. Both ends of the fixture need to be marked on wall. This is Point A.

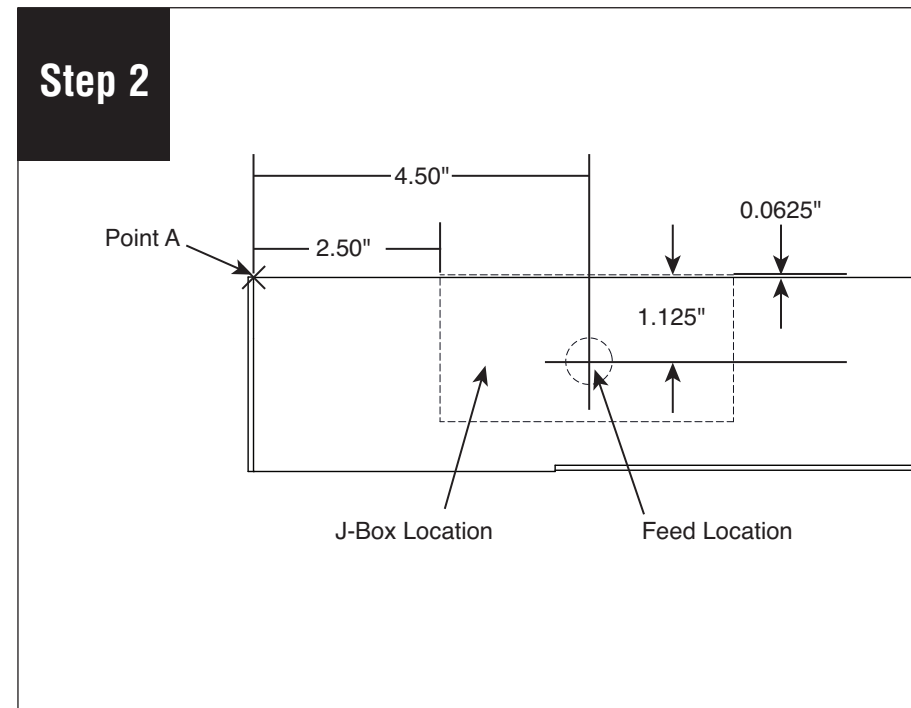

Determine feed location by measuring a horizontal line 4.5" from point A toward center of fixture, then 1.125" downward. Mark this spot for the feed. Centering J-box and install over feed location. Leave 8-10" of power wire exposed.

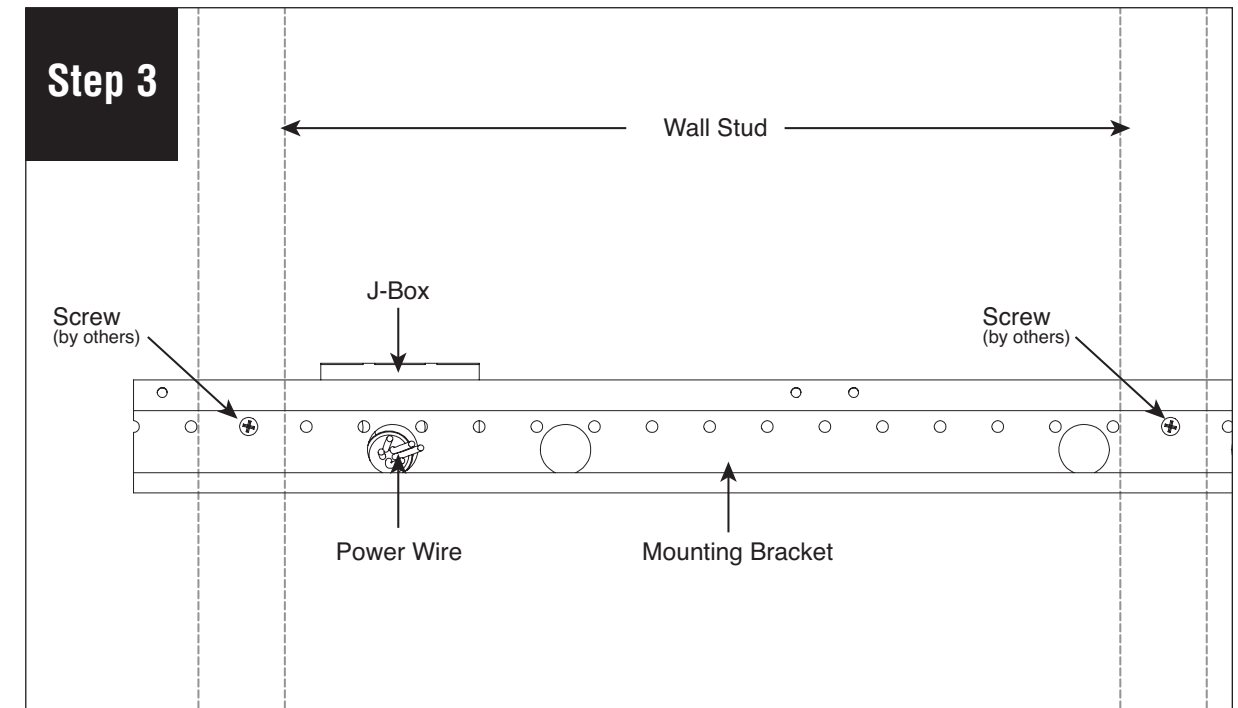

Position mounting bracket so feed holes is aligned with J-box feed and pull wire leads through. Secure one side of mounting bracket to the wall. Using a level, secure opposite side of mounting bracket to wall. Secure mounting bracket to each wall stud. Use molly style fastener at ends if stud is not available.

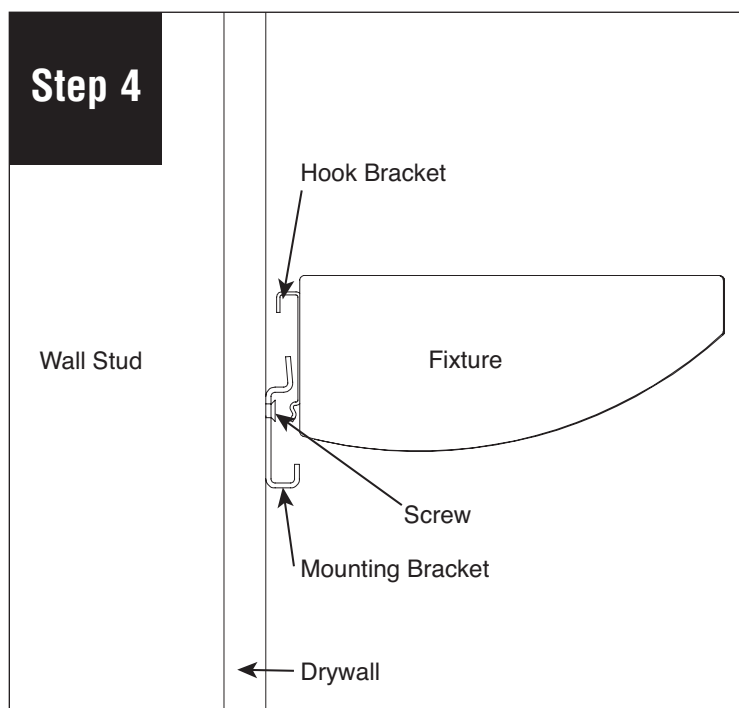

Holding fixture parallel to wall and slightly above bracket, slide fixture straight down to engage hooks on top and bottom of mounting bracket. Align end of fixture with end of bracket.

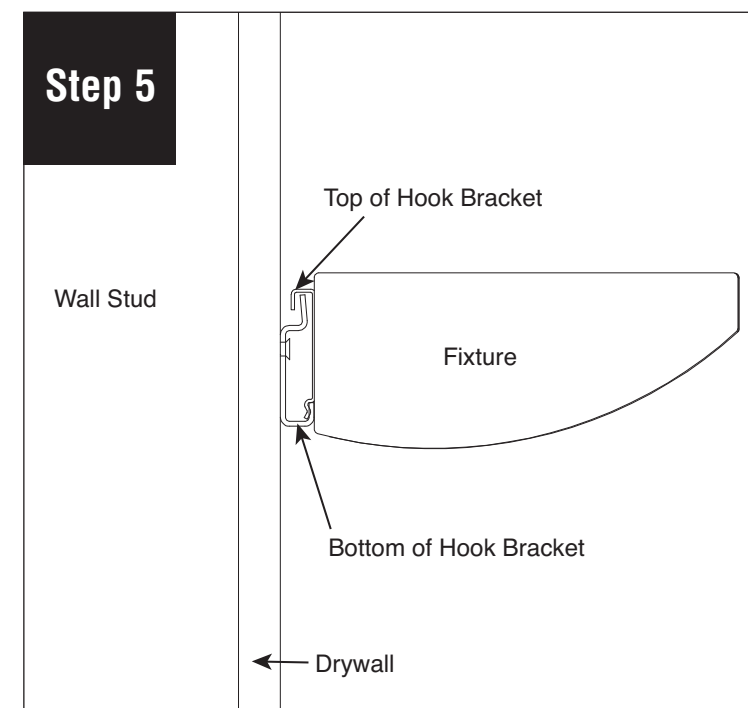

Check to ensure top and bottom of hook bracket are engaged in wall mounting bracket.

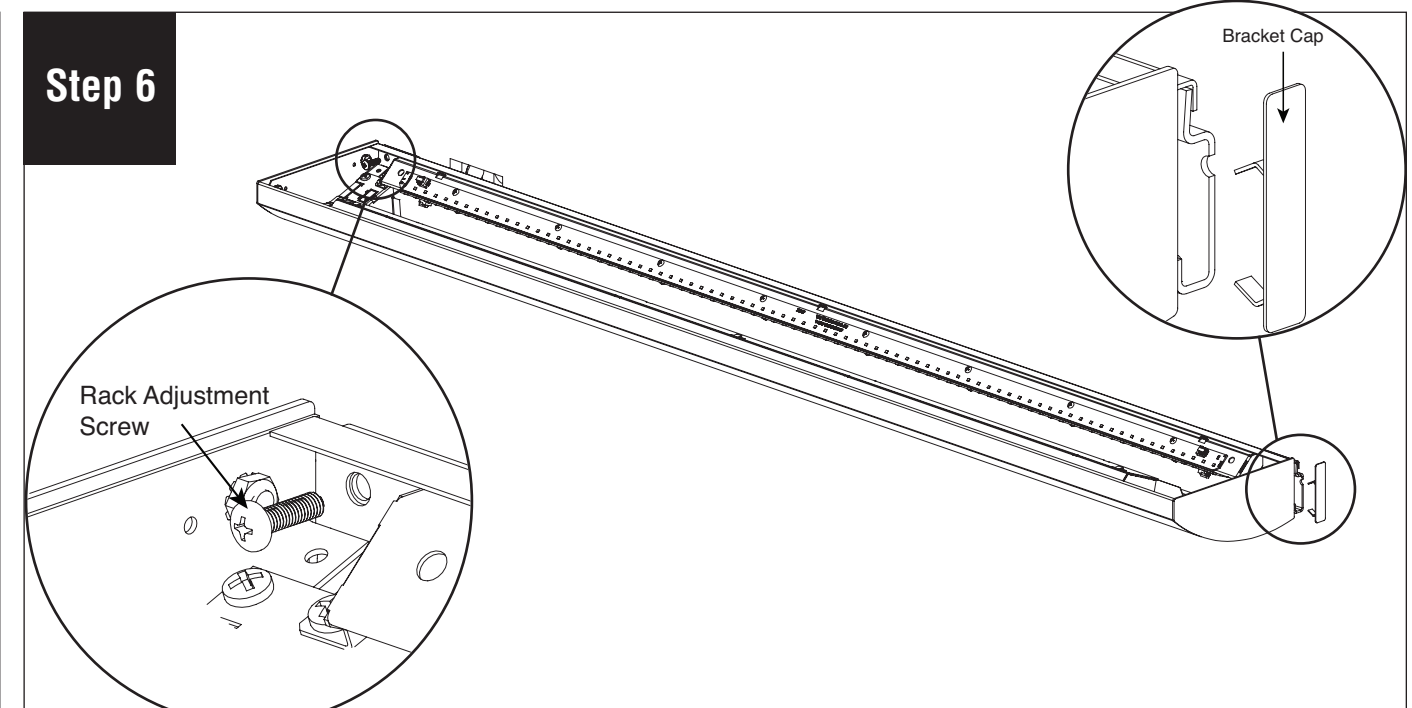

Insert rack adjustment screw (provided) at each hook bracket location and thread into mounting bracket. tighten/release to raise of lower fixture. Place bracket cap on each exposed end of mounting bracket and ends of run.

Note: All power connections to be installed to local/national codes by a Certified Electrician.

S12 LED Wall Mount 2E Joiner Installation Instructions

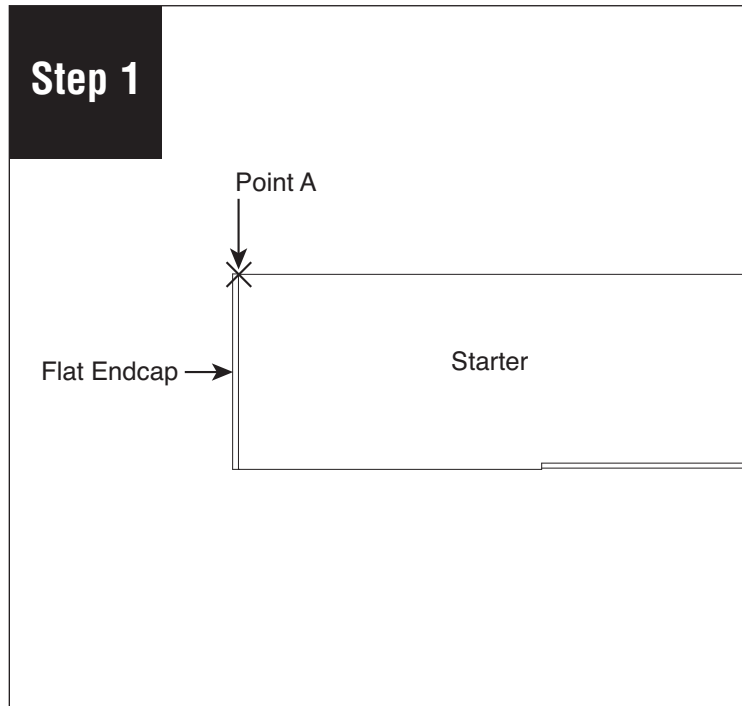

Position fixture on wall in desired location. Mark on wall the point where the end cap and the fixture body meet. Both ends of the fixture need to be marked on wall. This is Point A.

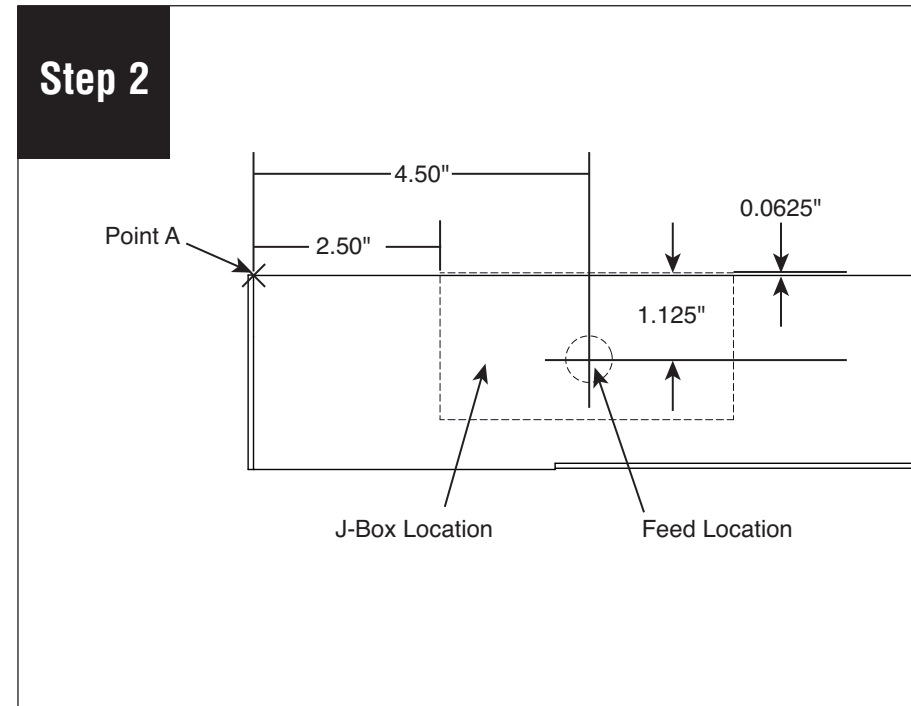

Determine feed location by measuring a horizontal line 4.5" from point A toward center of fixture, then 1.125" downward. Mark this spot for the feed. Centering J-box and install over feed location. Leave 8-10" of power wire exposed.

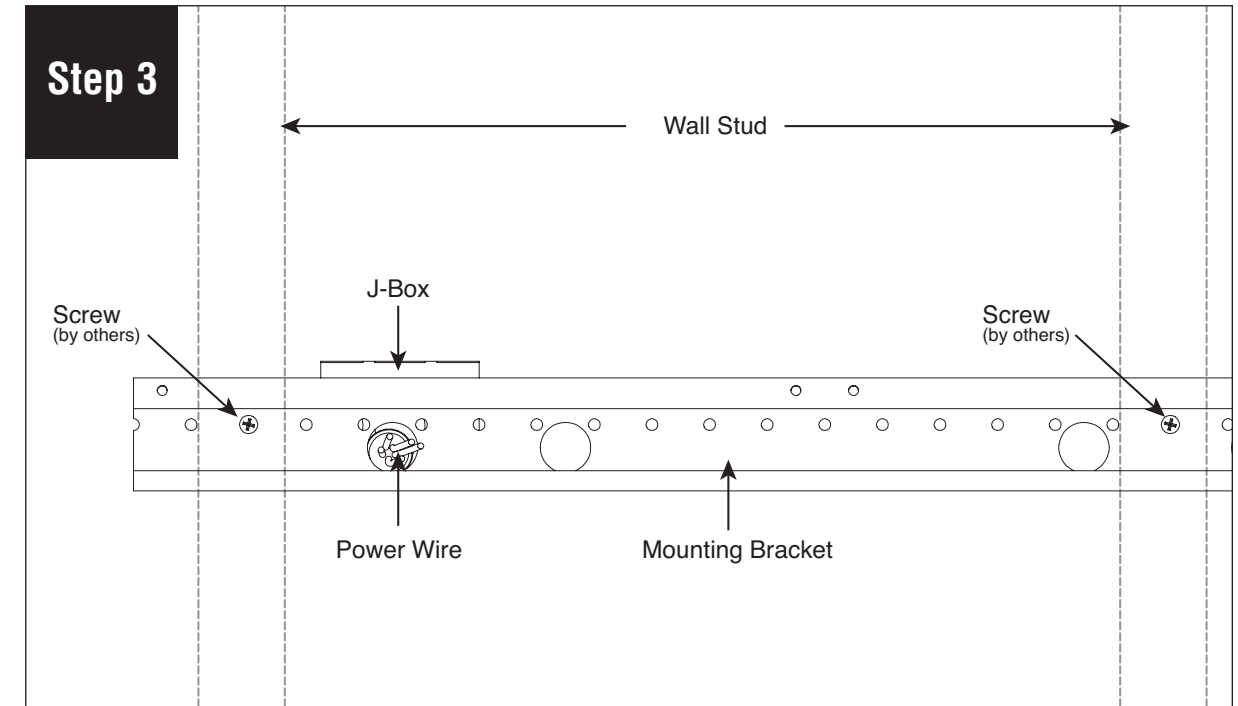

Position mounting bracket so feed holes is aligned with J-box feed and pull wire leads through. Secure one side of mounting bracket to the wall. Using a level, secure opposite side of mounting bracket to wall. Secure mounting bracket to each wall stud. Use molly style fastener at ends if stud is not available.

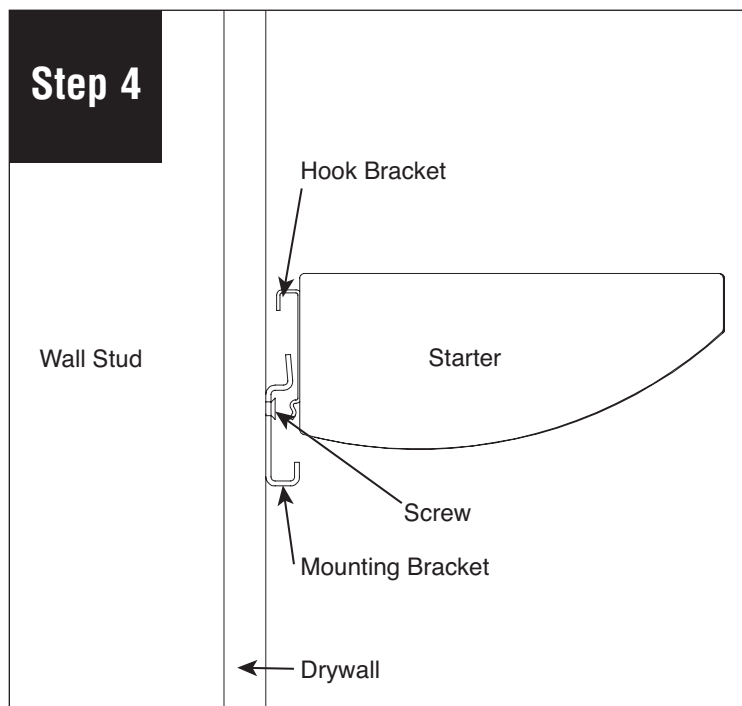

Holding fixture parallel to wall and slightly above bracket, slide fixture straight down to engage hooks on top and bottom of mounting bracket. Align end of fixture with end of bracket.

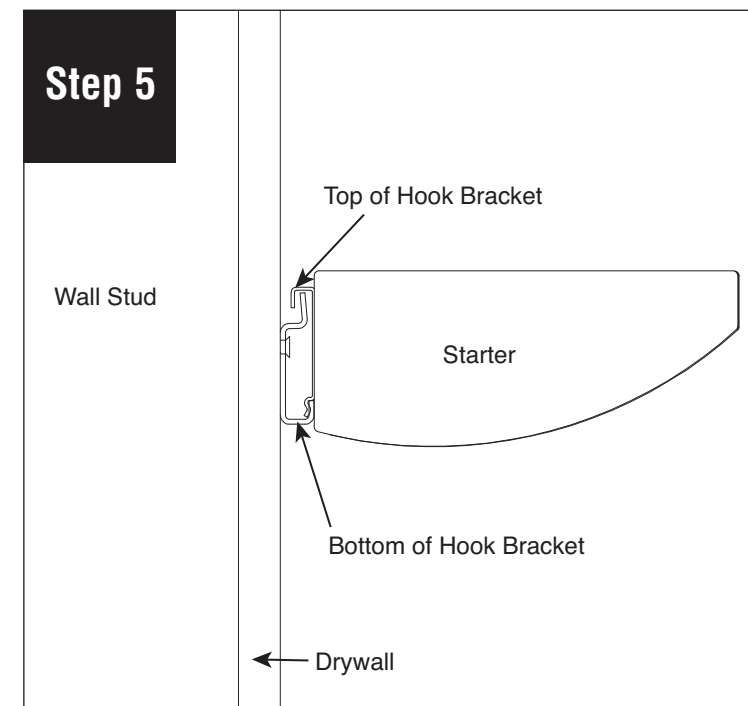

Check to ensure top and bottom of hook bracket are engaged in wall mounting bracket.

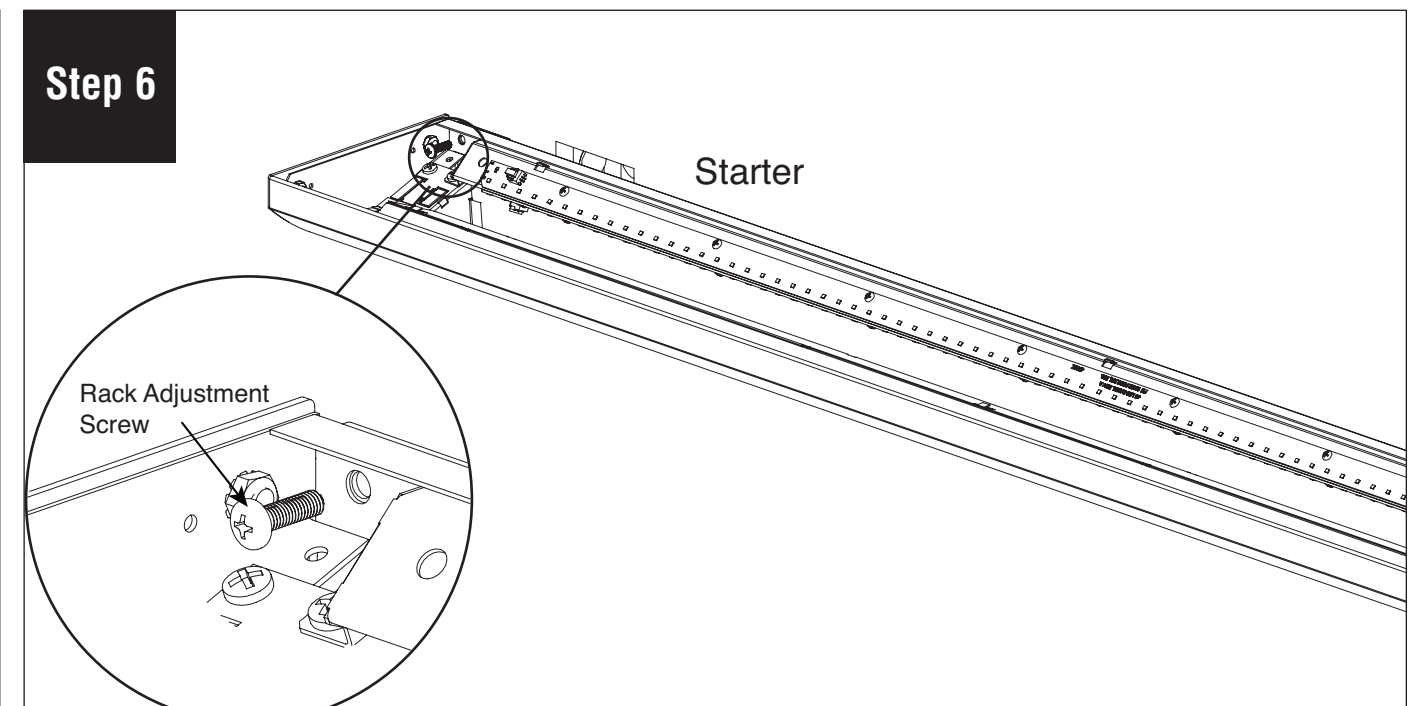

Insert rack adjustment screw (provided) at each hook bracket location and thread into mounting bracket. tighten/release to raise of lower fixture. Place bracket cap on each exposed end of mounting bracket and ends of run.

Note: All power connections to be installed to local/national codes by a Certified Electrician.

S12 LED Wall Mount 2E Joiner Installation Instructions

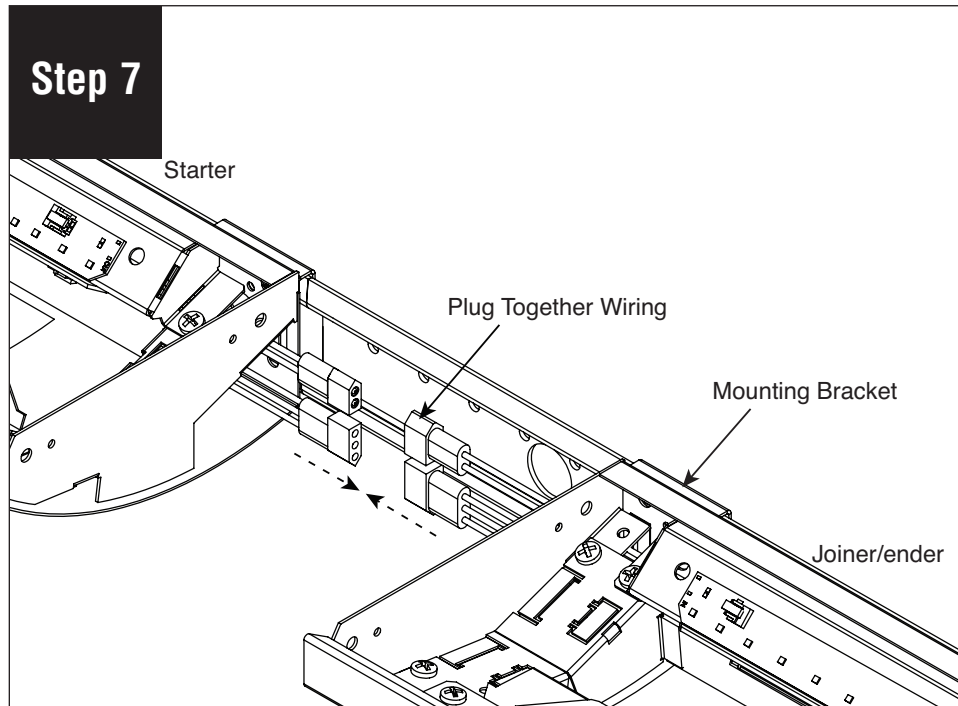

Hold joiner/ender fixture up to wall. Connect plug together wiring

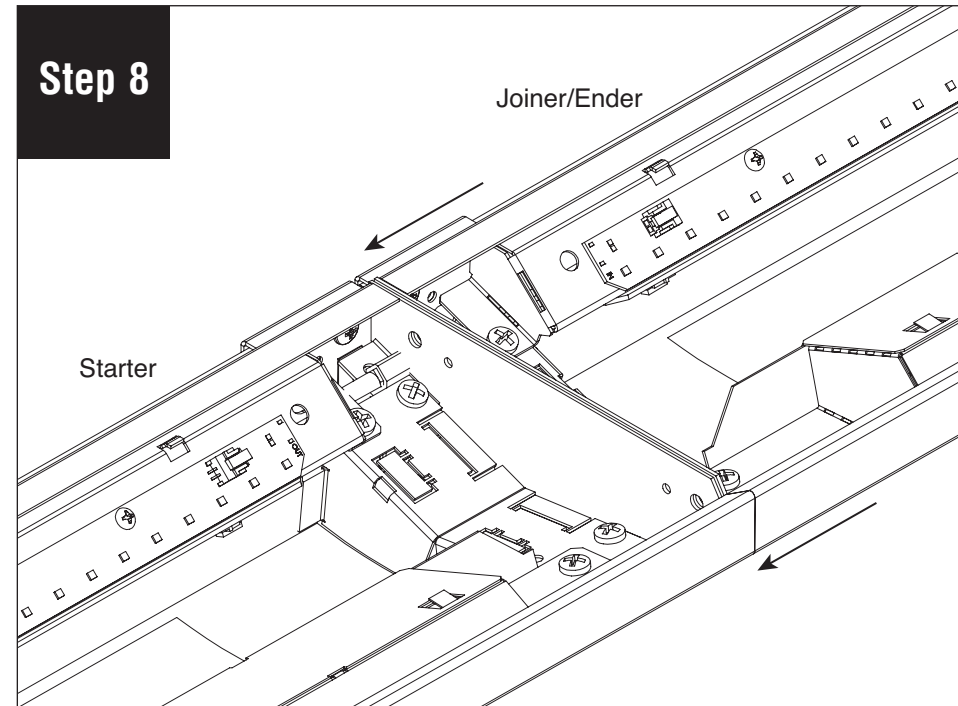

Slide joiner/ender to starter.

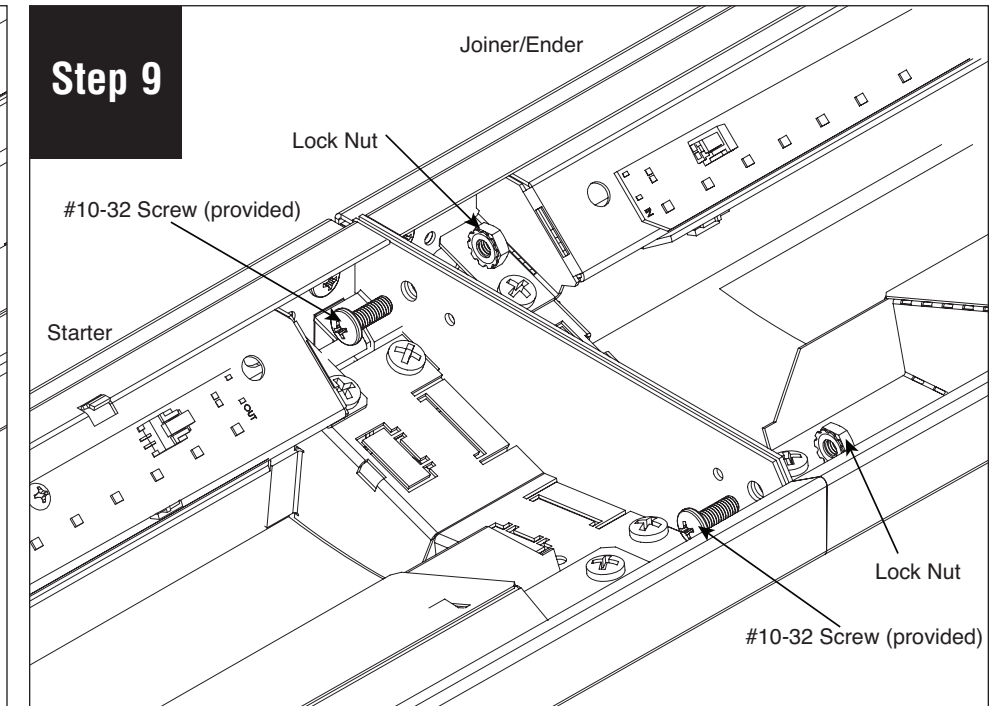

Secure fixtures together with 2 joiner #10-32 screws and lock nuts (provided) to complete connection.

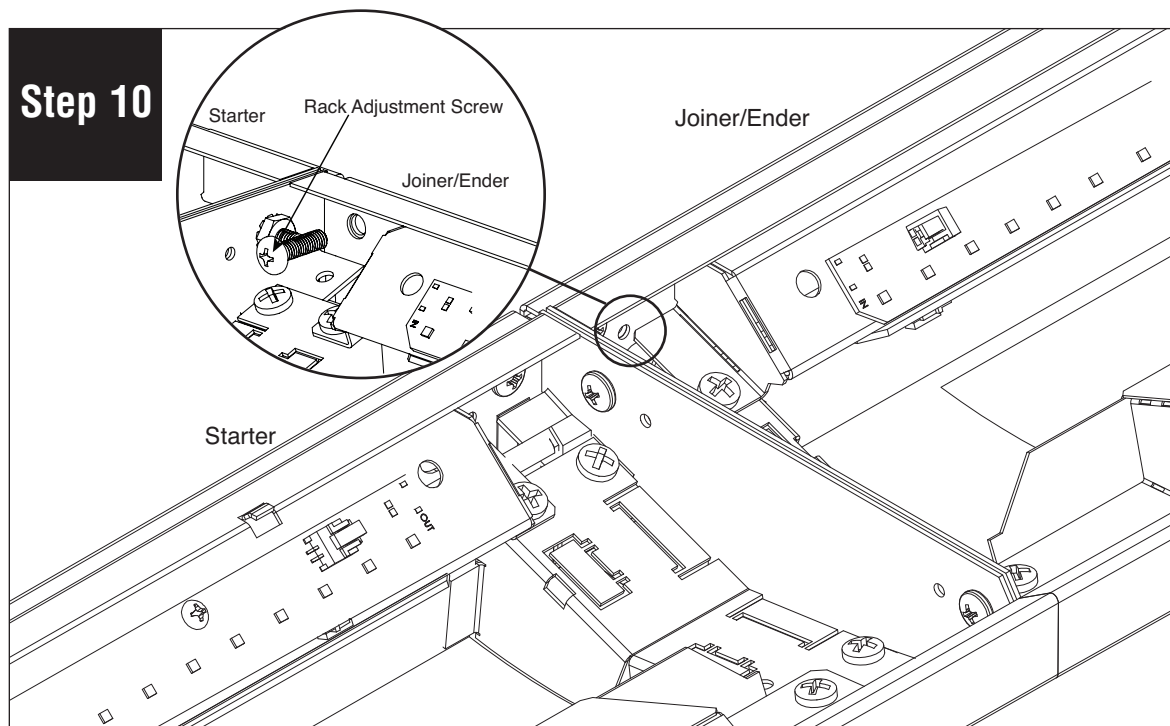

Insert one #8-32 rack adjustment screw (provided) on each side of joint/ender into mounting bracket. Tighten/loosen to level fixture. Turn power on to fixture.