

Series 12 Wall Mount 2E LED Engine Replacement Instructions

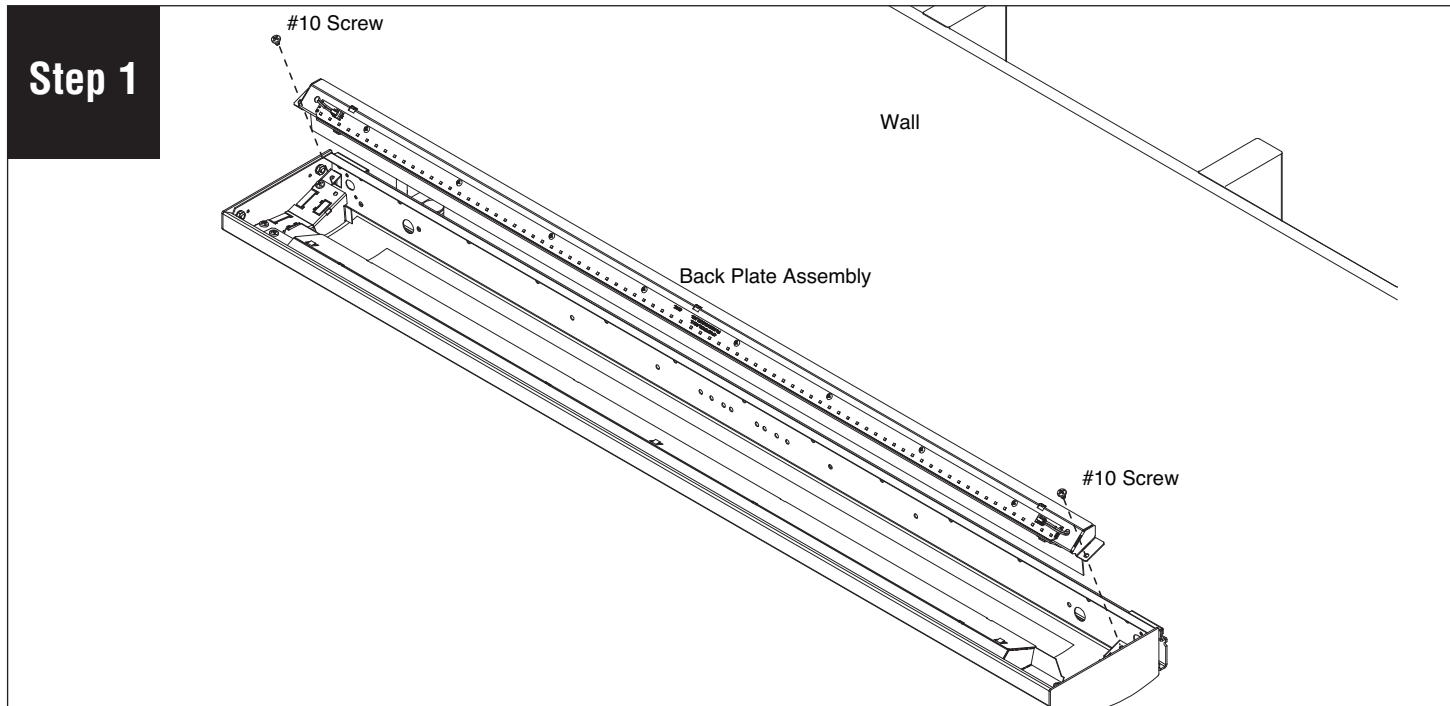

Remove #10-32 screws from both ends of LED back plate, then lift back plate assembly out of fixture.

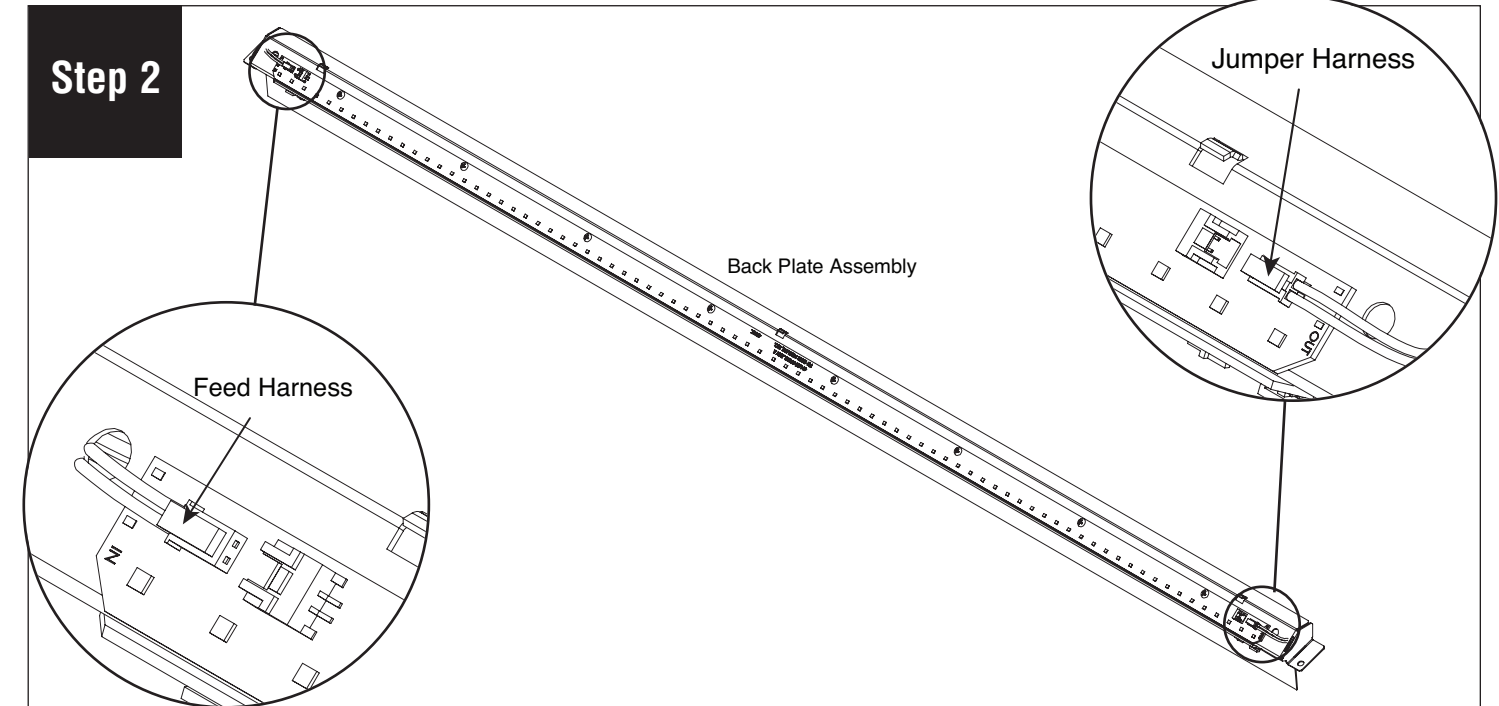

Disconnect feed harness and jumper harness.

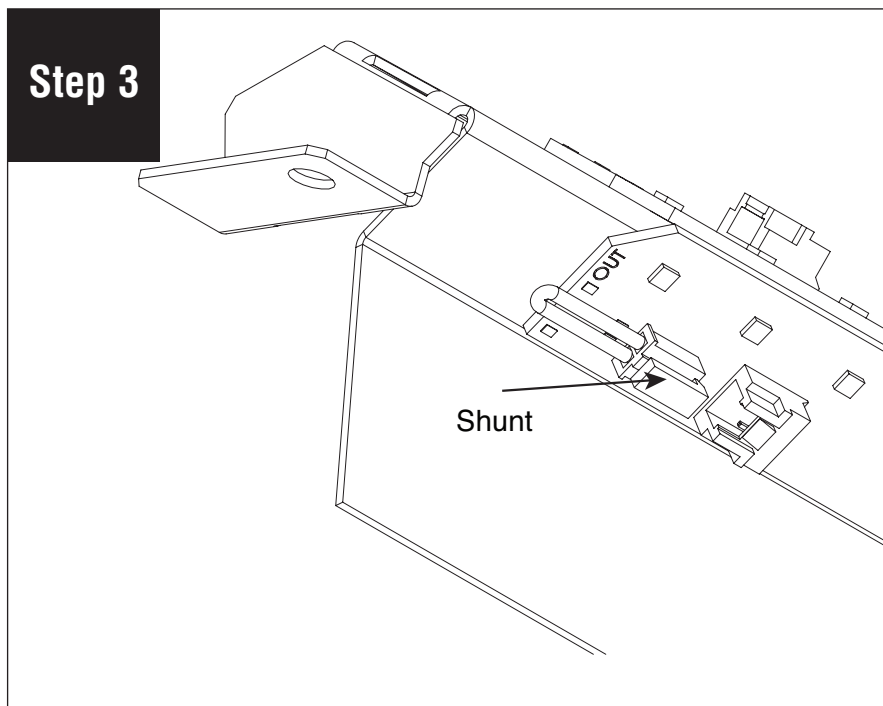

Disconnect shunt from bottom of the back plate assembly.

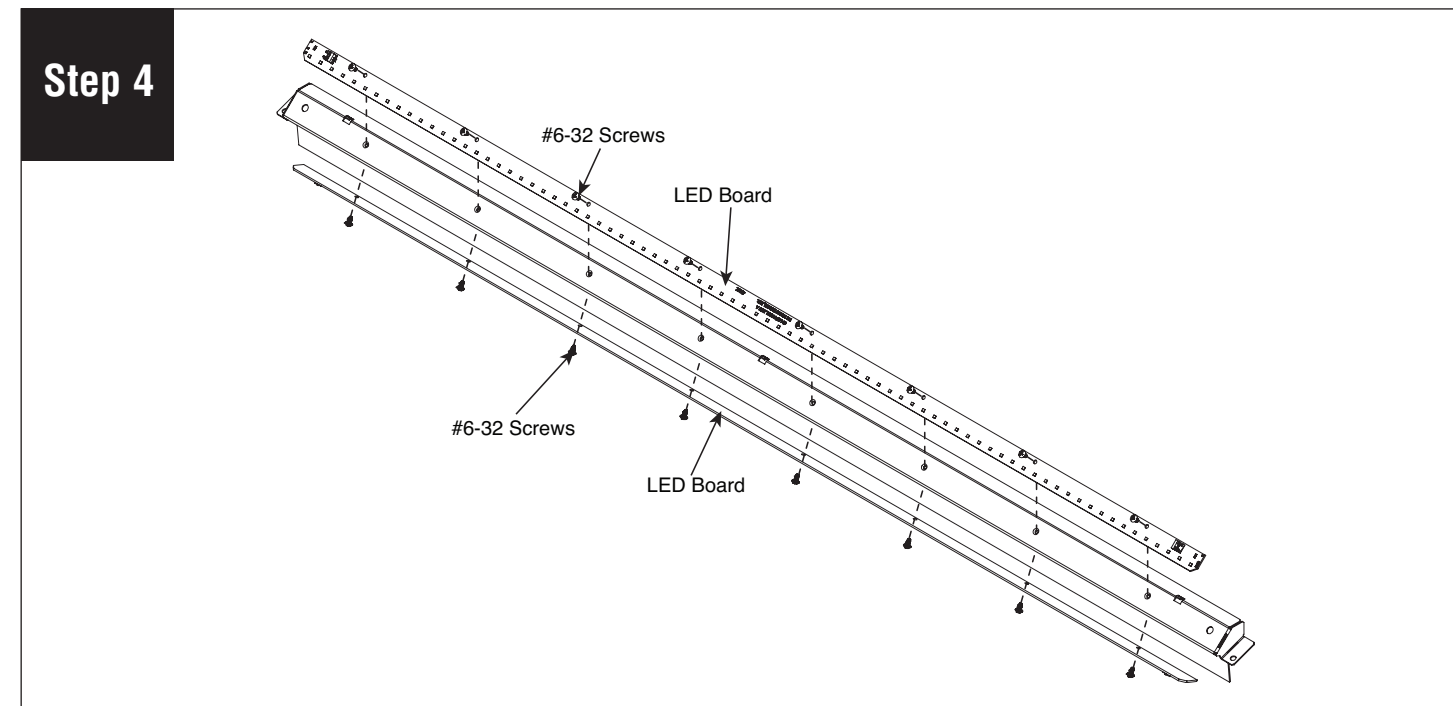

Remove #6-32 screws from LED boards and replace with the new LED boards. Reassemble fixture in reverse order. Turn power on to fixture.