

Series 12 2E LED Engine Replacement Instructions

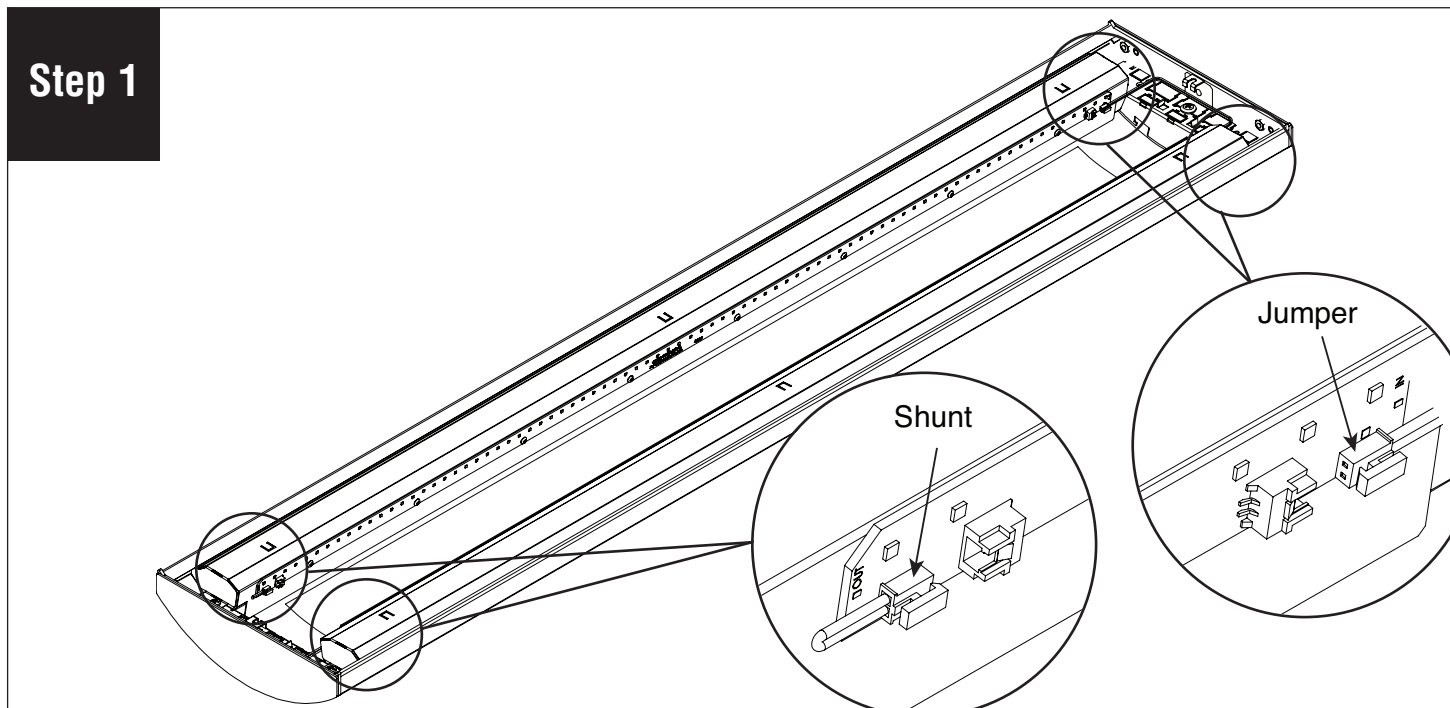

Disconnect all wiring harness. Keep the jumper cable and re-use with new LED engine.

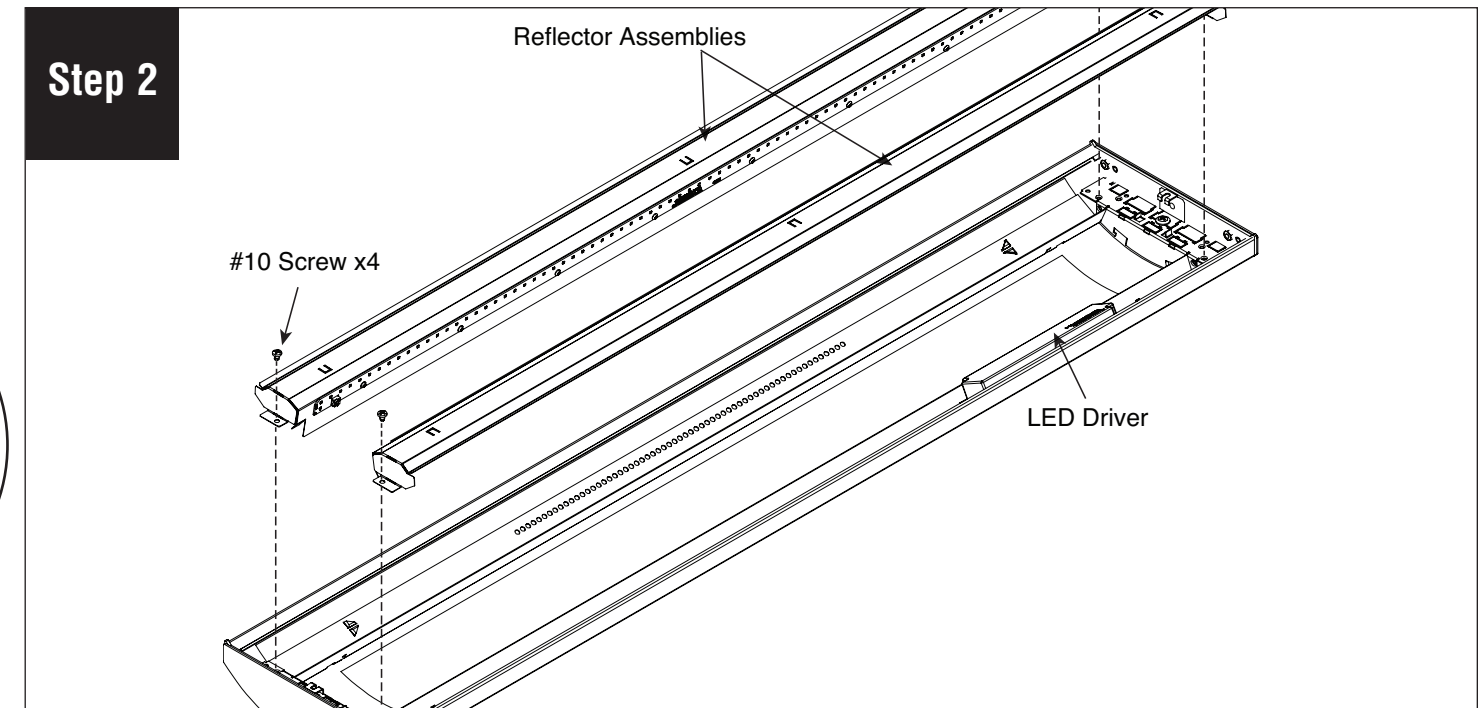

Remove #10 screws on both ends of reflector assemblies then remove the assemblies.

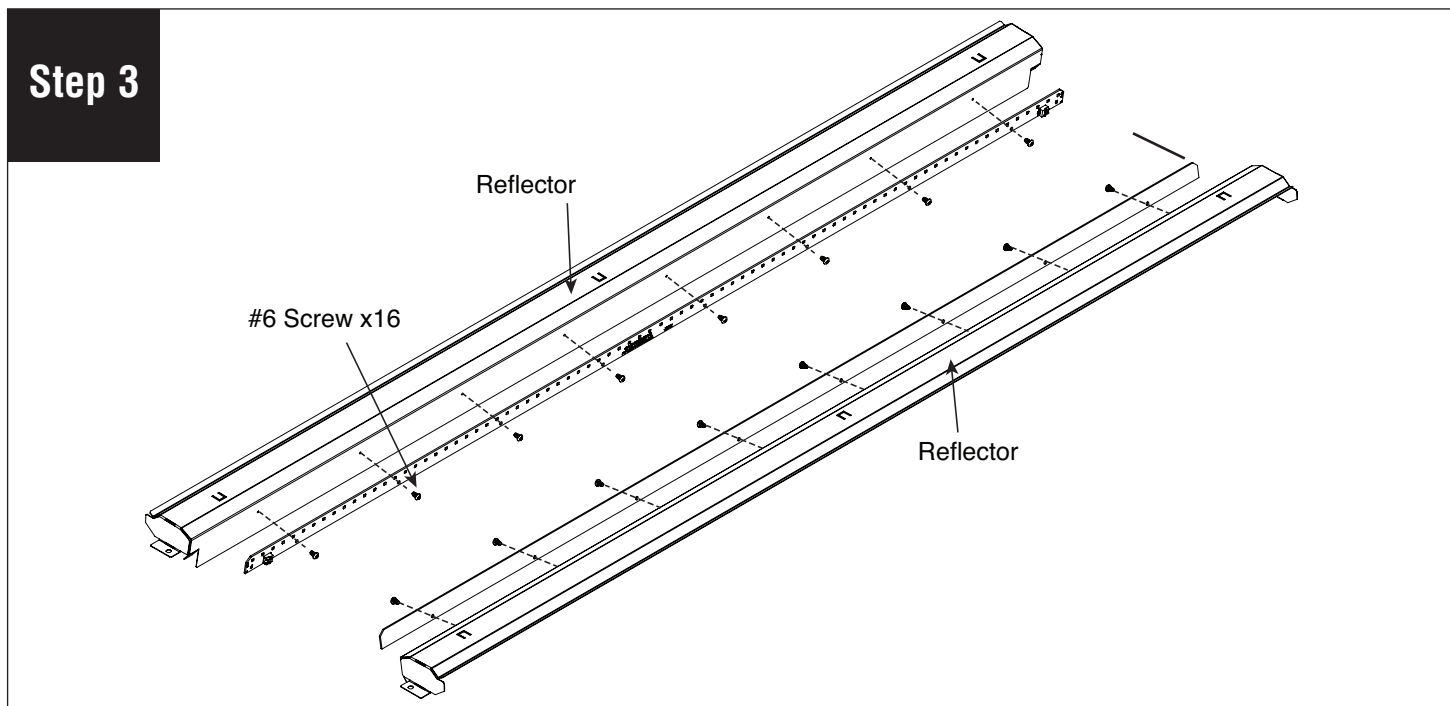

Remove #6 screws holding LED boards onto reflectors and replace boards.

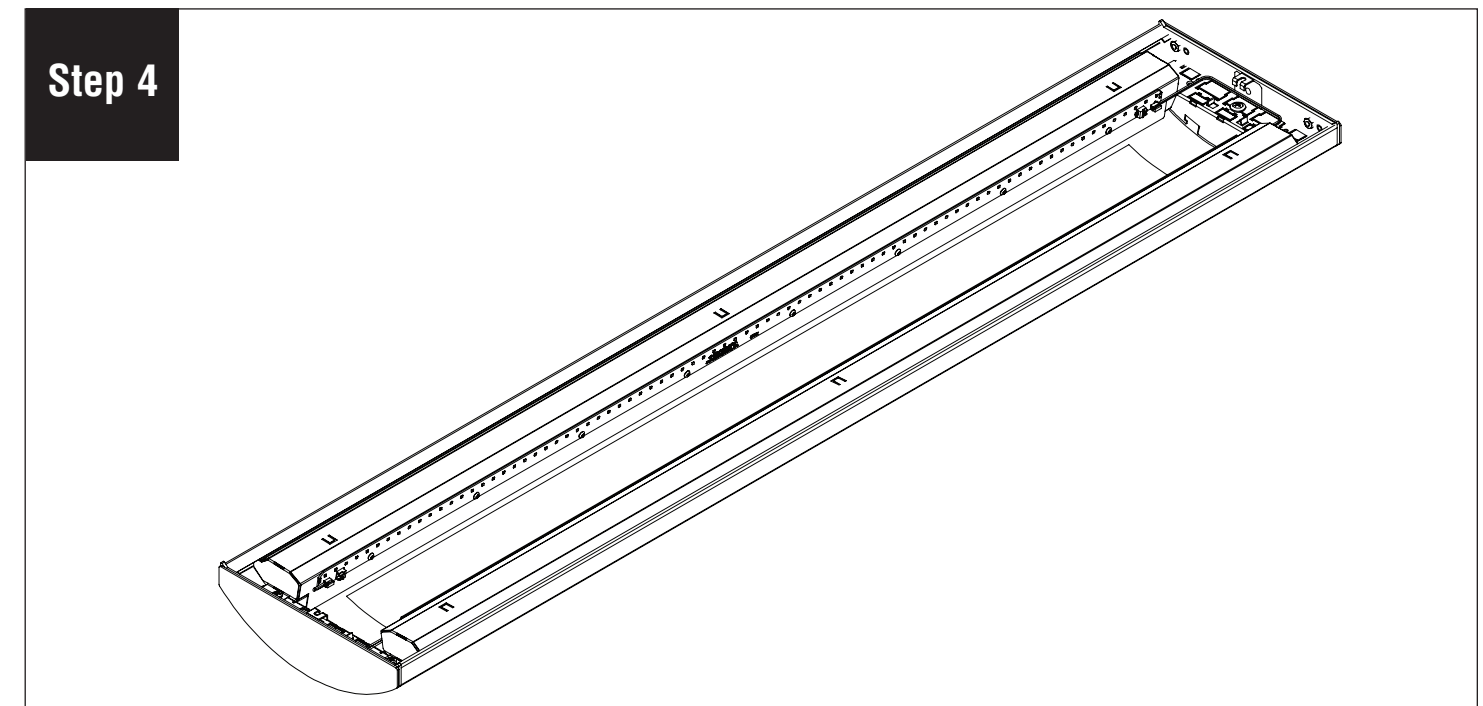

Reassemble fixture in reverse order. Turn power on to fixture.