

# HP-4 Wall Wash Direct Installation Instructions

## Overview

### NOTES

- All power connections should be installed according to local/national codes by a Certified Electrician.
- This installation requires **proper support** as each luminaire is being installed.
- **DO NOT attempt to join luminaires together on the floor.** Damage may result when lifted.



HELPFUL VIDEOS



0-10V Dimming



Universal & Robust Joints



Simple Plug-Together Wiring

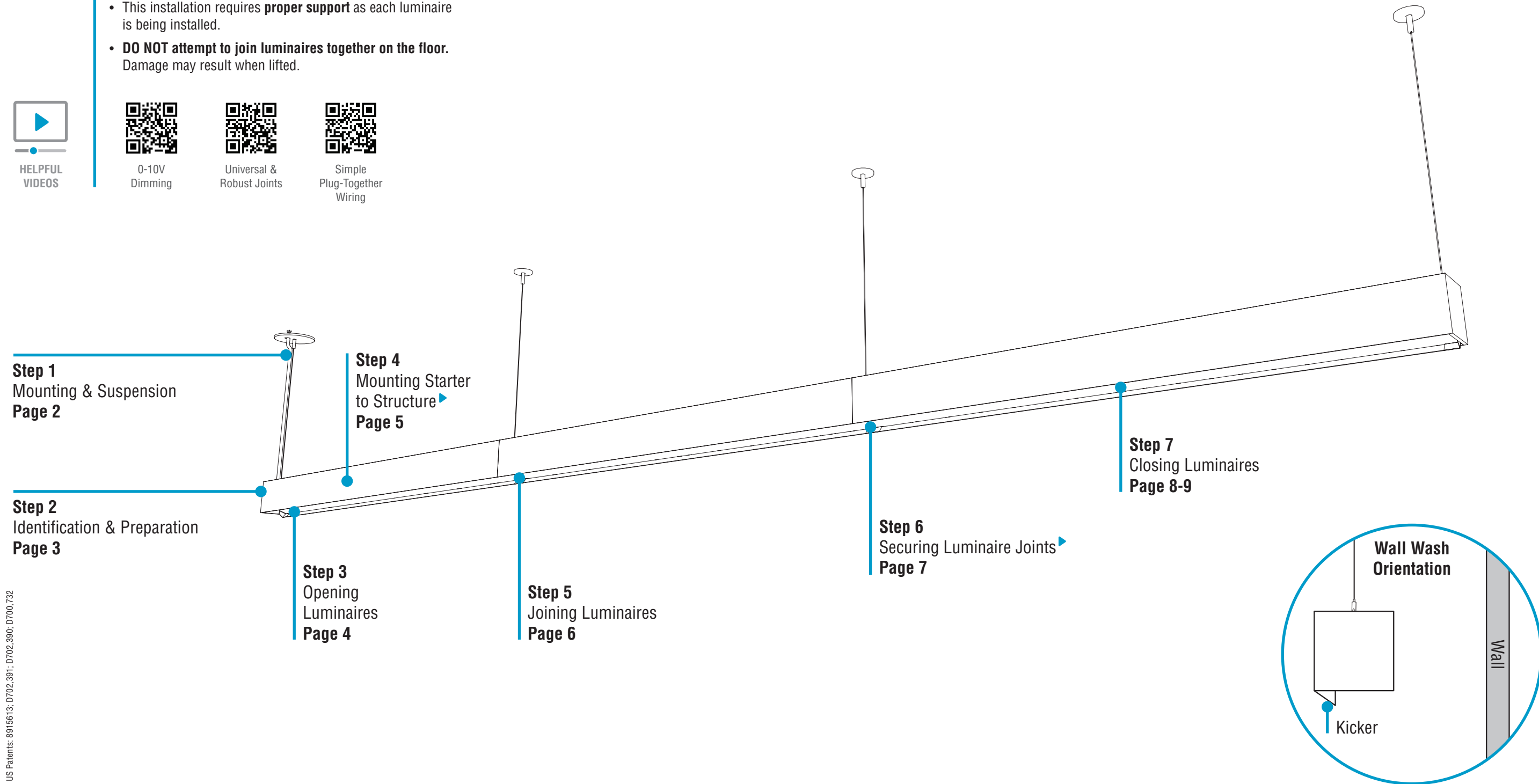

**Step 1**  
Mounting & Suspension  
Page 2

**Step 2**  
Identification & Preparation  
Page 3

**Step 3**  
Opening Luminaires  
Page 4

**Step 4**  
Mounting Starter to Structure  
Page 5

**Step 5**  
Joining Luminaires  
Page 6

**Step 6**  
Securing Luminaire Joints  
Page 7

**Step 7**  
Closing Luminaires  
Page 8-9

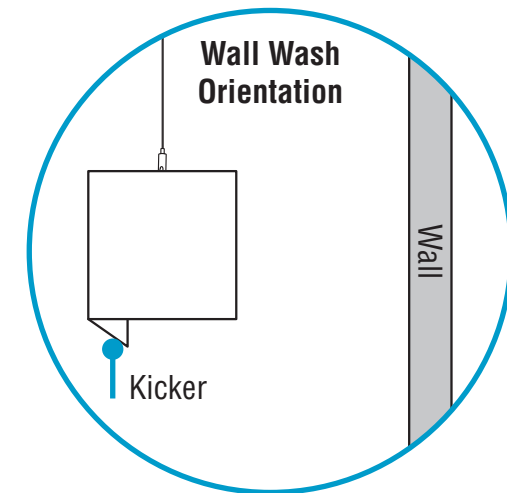

# HP-4 Wall Wash Direct Installation Instructions

## Step 1 - Mounting & Suspension

### Mounting Options

#### Option 1 T-Bar Mounting - GridBox™ and Caddy Clips

- Install GridBox™ and electrical conduit at feed locations.
- Install caddy clips at mounting point locations.
- All caddy clips are to be secured to structure, per local building codes.

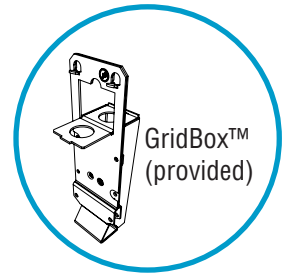

#### Option 2 Drywall (C4) or other hard surfaces\* - J-Box and Anchor Bolts

- Install J-Box and electrical conduit at feed locations.
- Install anchor bolts at mounting point locations.
- All anchor bolts are to be secured to structure, per local building codes.  
Other hard surfaces include: wood, sheet metal panels, steel beams, concrete or masonry. Use hardware appropriate for each surface material type.

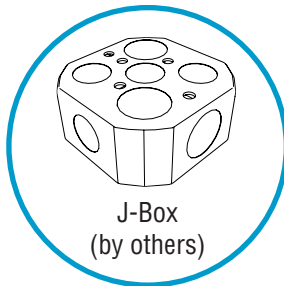

### Suspension Locations

X = Suspension Dimensions

Refer to Record Drawings and building plans to determine exact mounting, suspension points, and power feed locations.

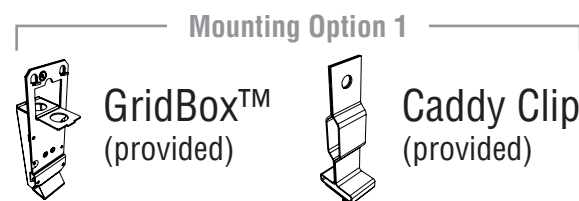
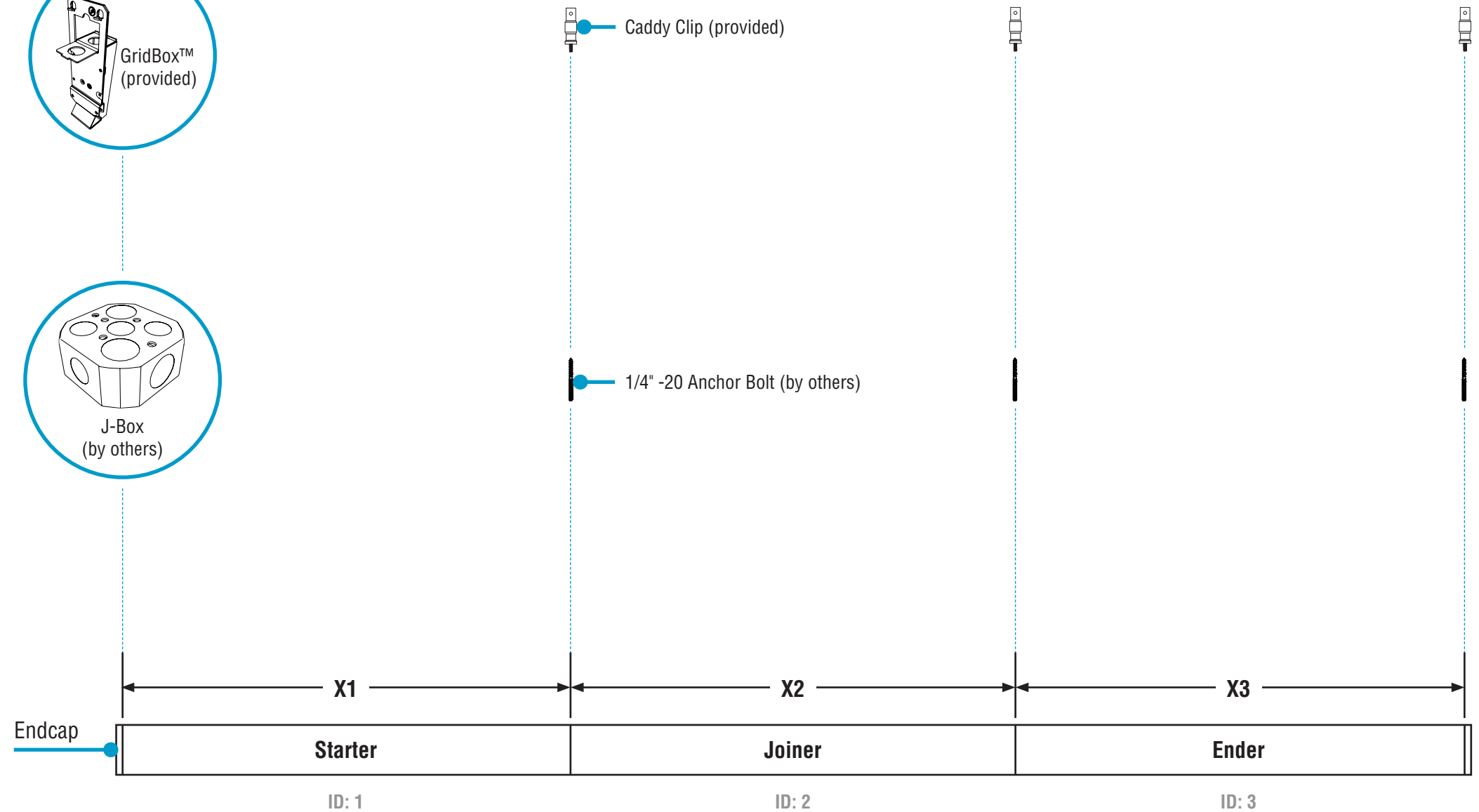

# HP-4 Wall Wash Direct Installation Instructions

## Step 2 - Identification & Preparation

### A. Identify Luminaires



Arrange luminaires in order according to ID# at their install locations.

**CAUTION**

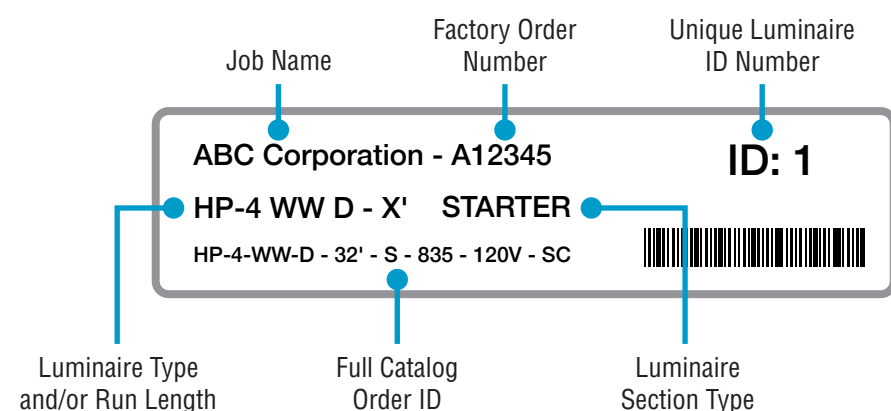

- Identify all luminaires by their ID label that can be found on the box, the diffuser, and inside the luminaire.
- NOTE:** Exact location of labels in these areas may vary.
- Remove all luminaires from their box.
- Refer to Record Drawings that can be found in the hardware kit.

### B. Remove Diffusers

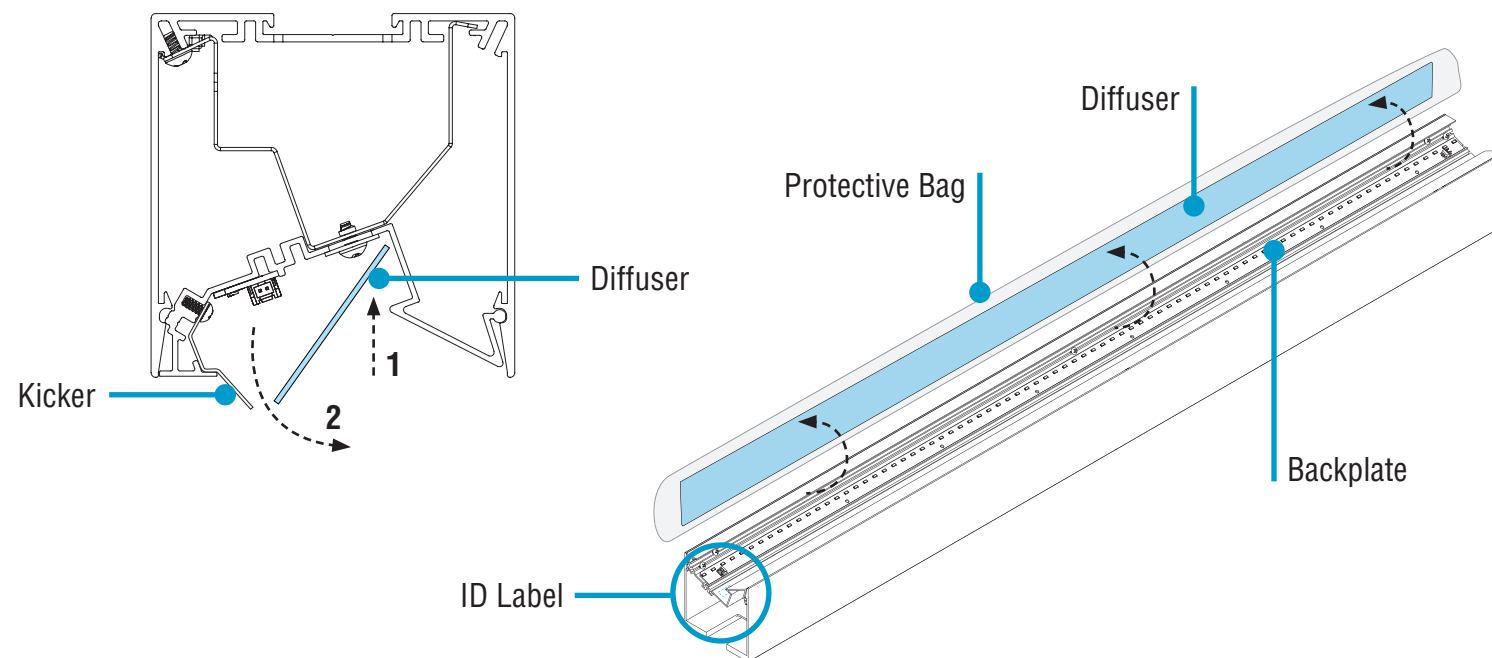

- 1. Push top edge of the diffuser into backplate.
- 2. Slide diffuser out of backplate.
- Carefully remove all diffusers, keeping them inside their protective bag.
- Set aside all diffusers to prevent from getting dirty or damaged.
- Ensure diffusers can be clearly identified back to its corresponding luminaire.
- If part of an independent run, **PROCEED TO STEP 4.**

### Kitted Hardware

- Finelite has provided items listed here, with their Finelite part numbers. These items can be found in separate boxes shipped with the luminaire.
- Account for all parts and set aside until they are needed.
- All other hardware needed for this installation will be by others.

Mounting Option 1		Mounting Option 2					
	<b>GridBox™</b> Part# 89159		<b>3-1/2" Canopy</b> Part# 89191		<b>Cable Bushing</b> Part# 94014		<b>Yoke Bracket</b> Part# 45042
	<b>Dual GridBox™</b> Part# 89199 Mounting & Suspension p. 2, Step 1		<b>3-1/2" Dual Feed Canopy</b> Part# 89192 Mounting Starter to Structure p. 5, Step 4 Joining Luminaires p. 6, Step 5		<b>Aircraft Cable</b> 50" - Part# 94515-12 (Std.) 100" - Part# 94515-14 150" - Part# 94515-18 Mounting Starter to Structure p. 5, Step 4 Joining Luminaires p. 6, Step 5		<b>#10-32 x 5/8" Screw</b> Part# 94144 Securing Luminaire Joints p. 7, Step 6
	<b>Caddy Clip</b> C1 Ceiling - Part# 94001 C2 Ceiling - Part# 94020 C3 Ceiling - Part# 94029 Mounting & Suspension p. 2, Step 1		<b>2" T-Bar Support Canopy</b> Part# 89193 Mounting Starter to Structure p. 5, Step 4 Joining Luminaires p. 6, Step 5		<b>5" Canopy</b> Part# 94085		<b>Slip Ring w/ Set Screw</b> Part# 94015 Mounting Starter to Structure p. 5, Step 4 Joining Luminaires p. 6, Step 5
			<b>5" Dual Feed Canopy</b> Part# 94145 Mounting Starter to Structure p. 5, Step 4 Joining Luminaires p. 6, Step 5		<b>1/4" Washer</b> Part# 94082 Opening Luminaires p. 4, Step 3 Closing Luminaires p. 8, Step 7		<b>#10 x 1/2" Screw</b> Part# 92081 Closing Luminaires p. 8, Step 7
			<b>2" Drywall Support Canopy</b> Part# 94017 Mounting Starter to Structure p. 5, Step 4 Joining Luminaires p. 6, Step 5				<b>#8-18 x 1/4" Screw</b> Part# 69026 Closing Luminaires p. 8, Step 7

# HP-4 Wall Wash Direct Installation Instructions

## Step 3 - Opening Luminaires

### A. Release Backplates

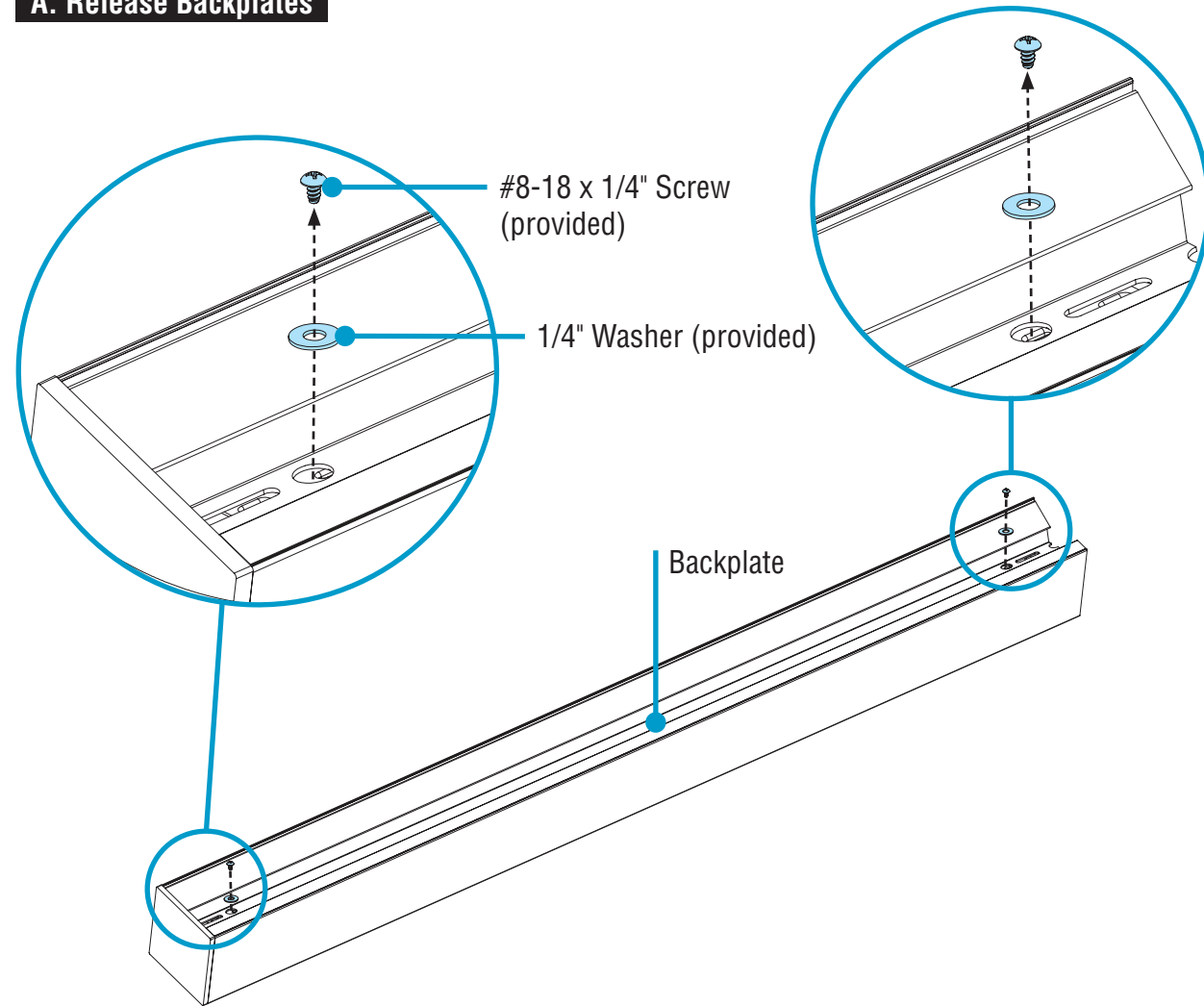

- **NOTE:** If installing an independent, leave backplates installed and **PROCEED TO STEP 4.**
- Release backplate from luminaire body by removing the #8-18 x 1/4" screw and 1/4" washer from both ends of the luminaire.
- **CAUTION:** Set these screws aside. Do not lose.

### B. Remove Backplates

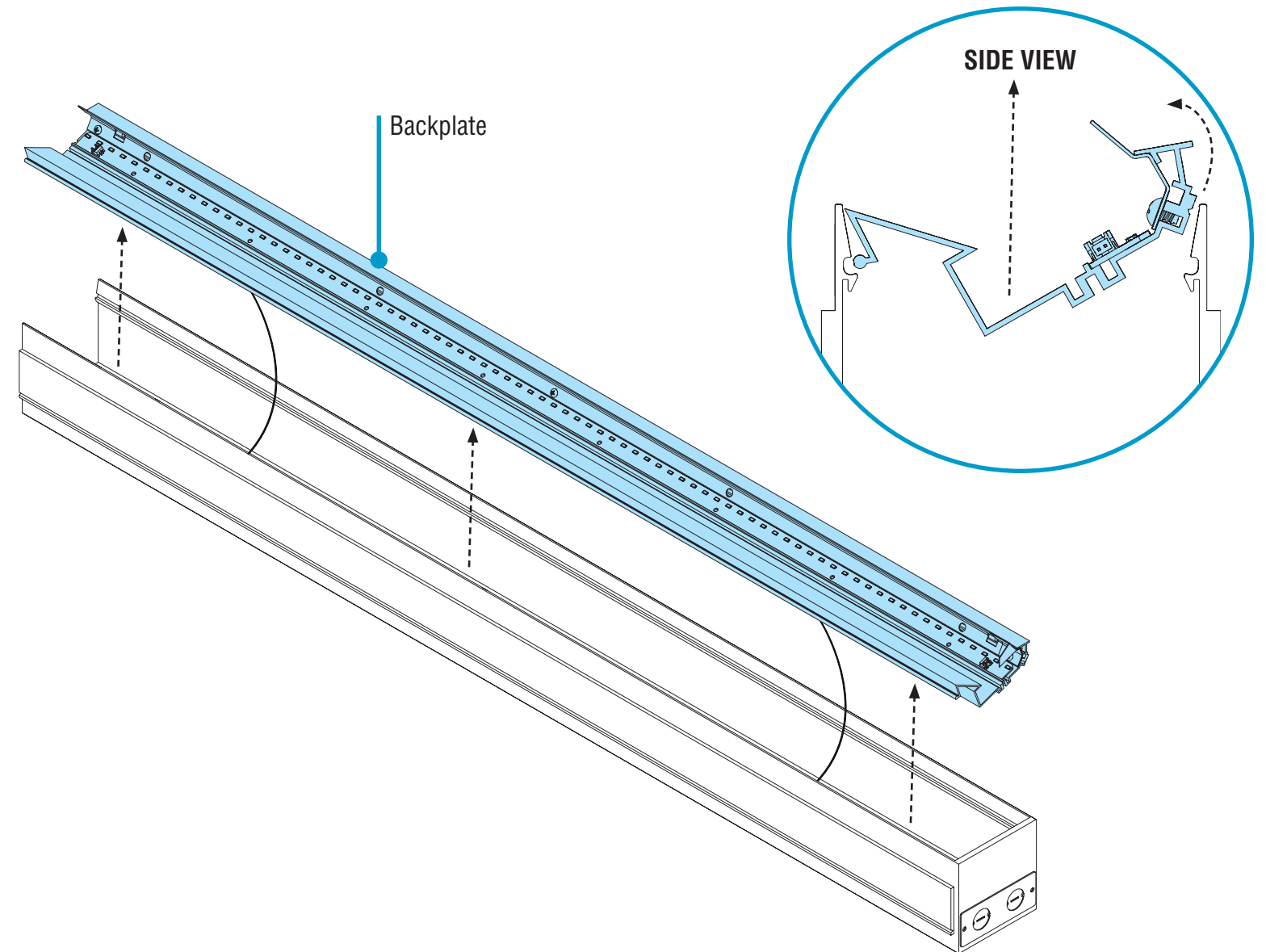

- Remove backplates by rotating then lifting **up and out** of the luminaire body.
- Keep backplate hanging with safety cables connected.



# HP-4 Wall Wash Direct Installation Instructions

## Step 4 - Mounting Starter to Structure

### A. Mount Starter to Structure

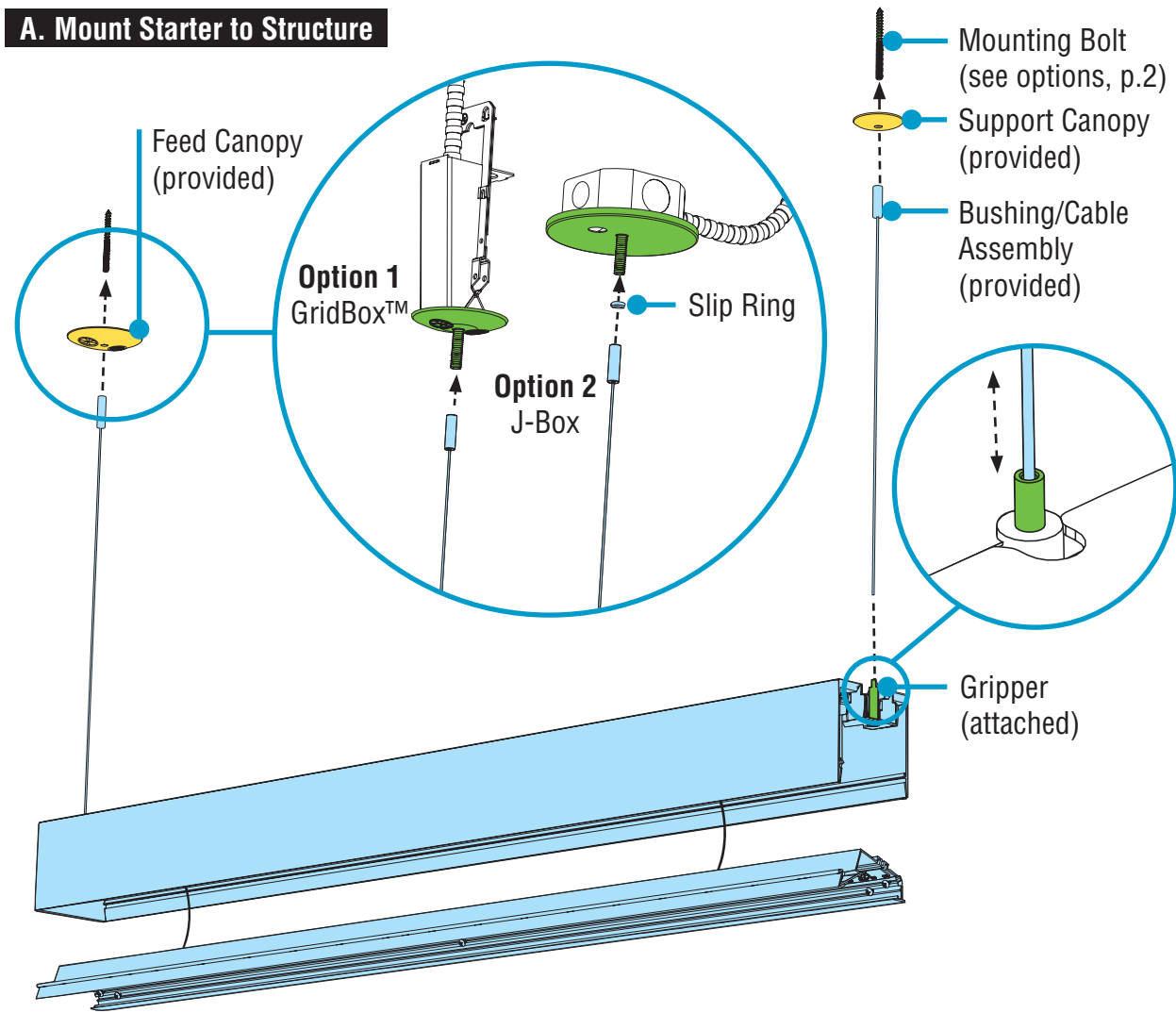

- Slide canopy appropriate for electrical type options onto mounting bolt (anchor bolt or caddy clip bolt).
- **(Option 2 only)** Slide slip ring onto bushing/cable assembly and thread onto mounting bolts. Secure slip ring with set screw at both mounting locations.
- Thread the bushing/cable assembly onto mounting bolts.
- While properly supporting luminaire, maneuver luminaire to ceiling as backplates hang via safety cable.
- Locate grippers at luminaire ends and feed aircraft cable through it by depressing top of gripper.
- Level all luminaires to desired height by depressing top of grippers to adjust cable lengths.
- **CRITICAL:** Level luminaire section. If part of an independent run, **PROCEED TO STEP 7.**

### B. Make Electrical Connections

WIRING LEGEND		
Black	Hot	Line Voltage
White	Neutral	Line Voltage
Green	Ground	
Grey	Dimming	0-10V DC
Purple	Dimming	0-10V DC

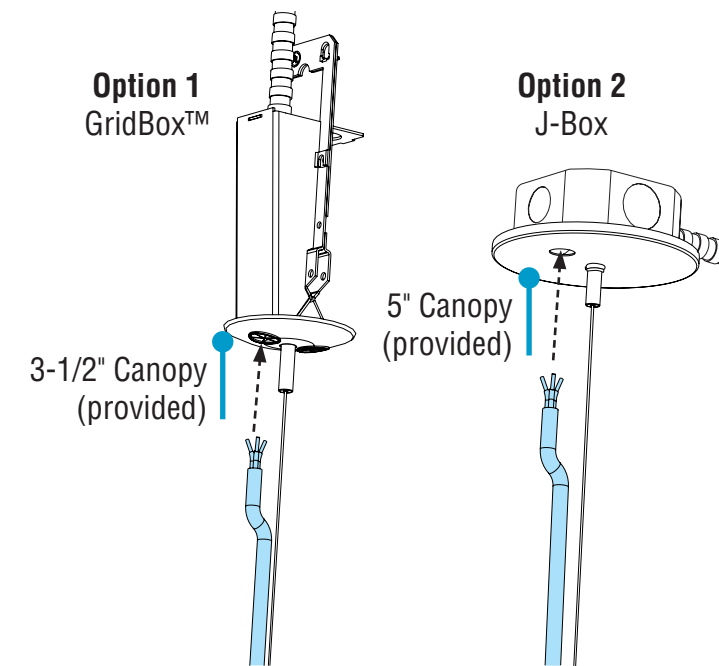

- **(Option 1)** Feed power cord through the 3-1/2" canopy and connect wires inside the GridBox™.
- **(Option 2)** Feed power cord through the 5" canopy and connect wires inside the J-Box.

**OPTIONAL Flexible Mount** pendant brackets are adjustable for custom mounting locations.

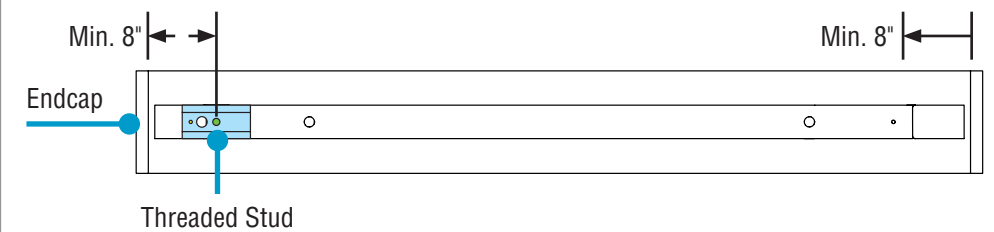

Luminaire Length	Max.	Min.
8'-12'	1'-10"	8"
2' to 8'	10"	6"

• **NOTE:** Minimum and Maximum Distances

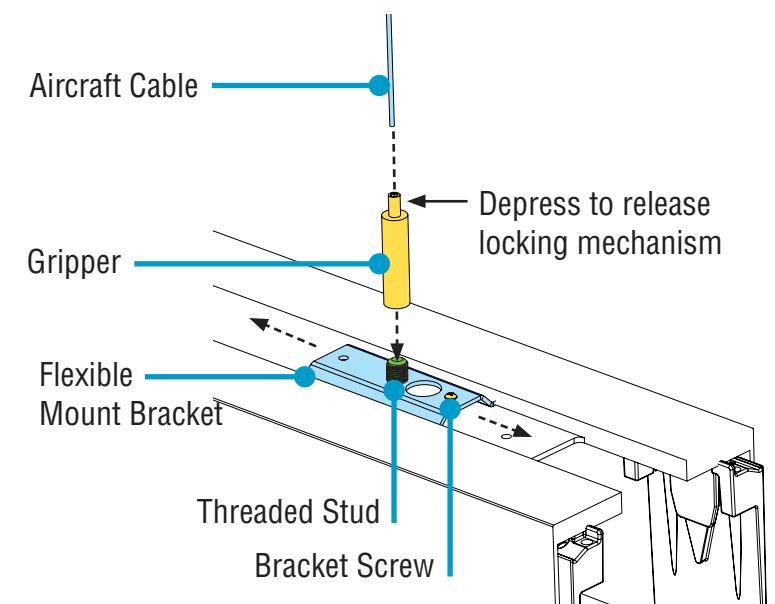

- Loosen (**but do not remove**) the bracket screw.
- Slide flexible mount pendant bracket to desired location and tighten screw to secure.
- Attach gripper onto threaded stud.
- Feed bushing/cable assembly through gripper by depressing top of gripper.
- Allow excess cable to rest atop luminaire. If necessary crimp then trim. **SEE STEP 7.**

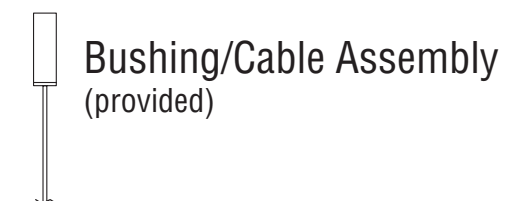
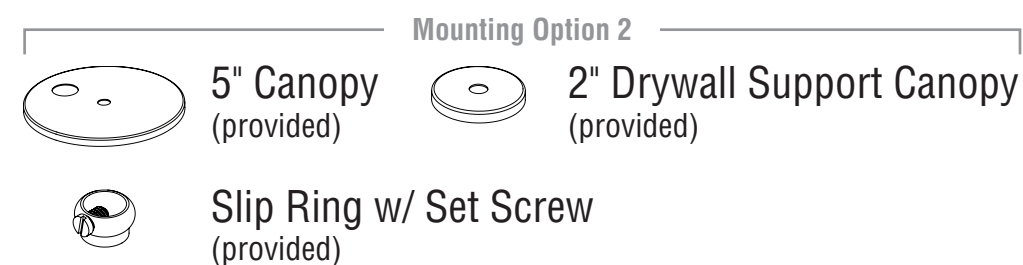
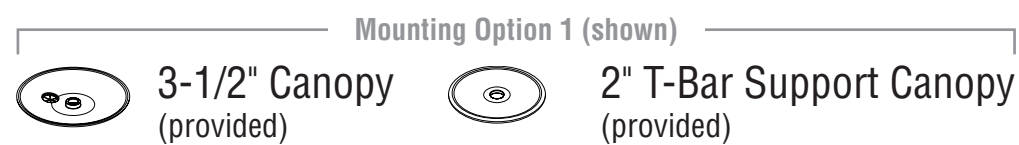

0-10V Dimming

# HP-4 Wall Wash Direct Installation Instructions

## Step 5 - Joining Luminaires

### A. Mount Joiner/Ender to Structure



**CAUTION**

**DO NOT** attempt to join luminaires together on the floor. Damage may result when lifted. Follow these instructions.

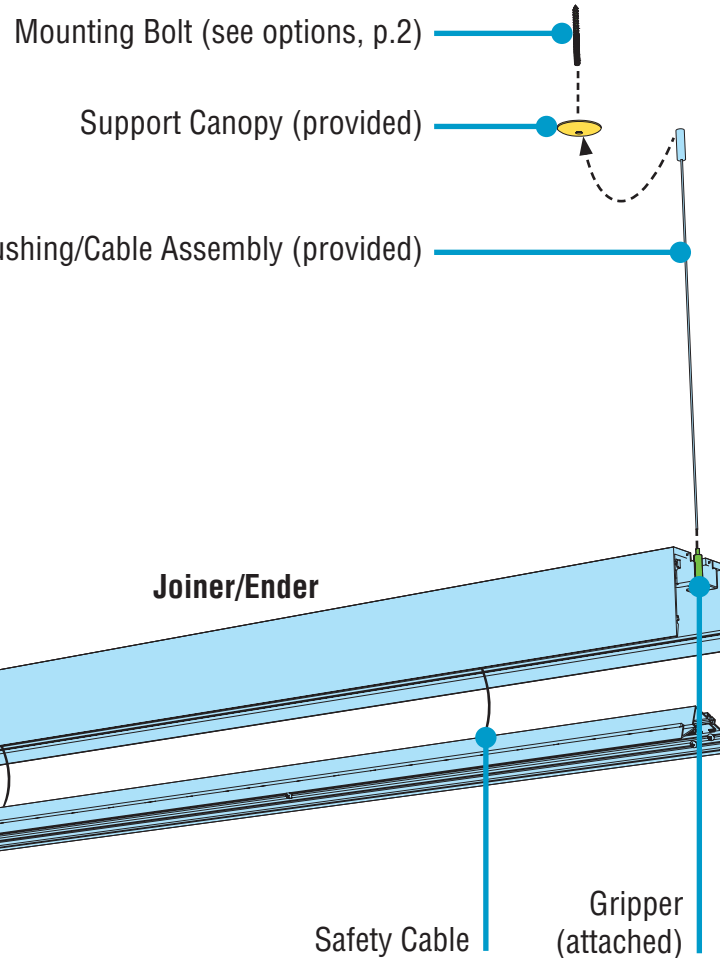

- For the joiner/ender luminaire, slide canopy appropriate for electrical type onto mounting bolt (anchor bolt or caddy clip bolt).
- Thread the bushing/cable assembly onto mounting bolt.
- While properly supporting luminaire, maneuver luminaire to ceiling.
- Locate gripper at luminaire ends and feed aircraft cable through it by depressing top of gripper.

### B. Join Luminaires



**CAUTION**

Once luminaires are aligned together, **joiner luminaire is not yet secure.** Ensure it does not slide off as it rests on the starter luminaire.

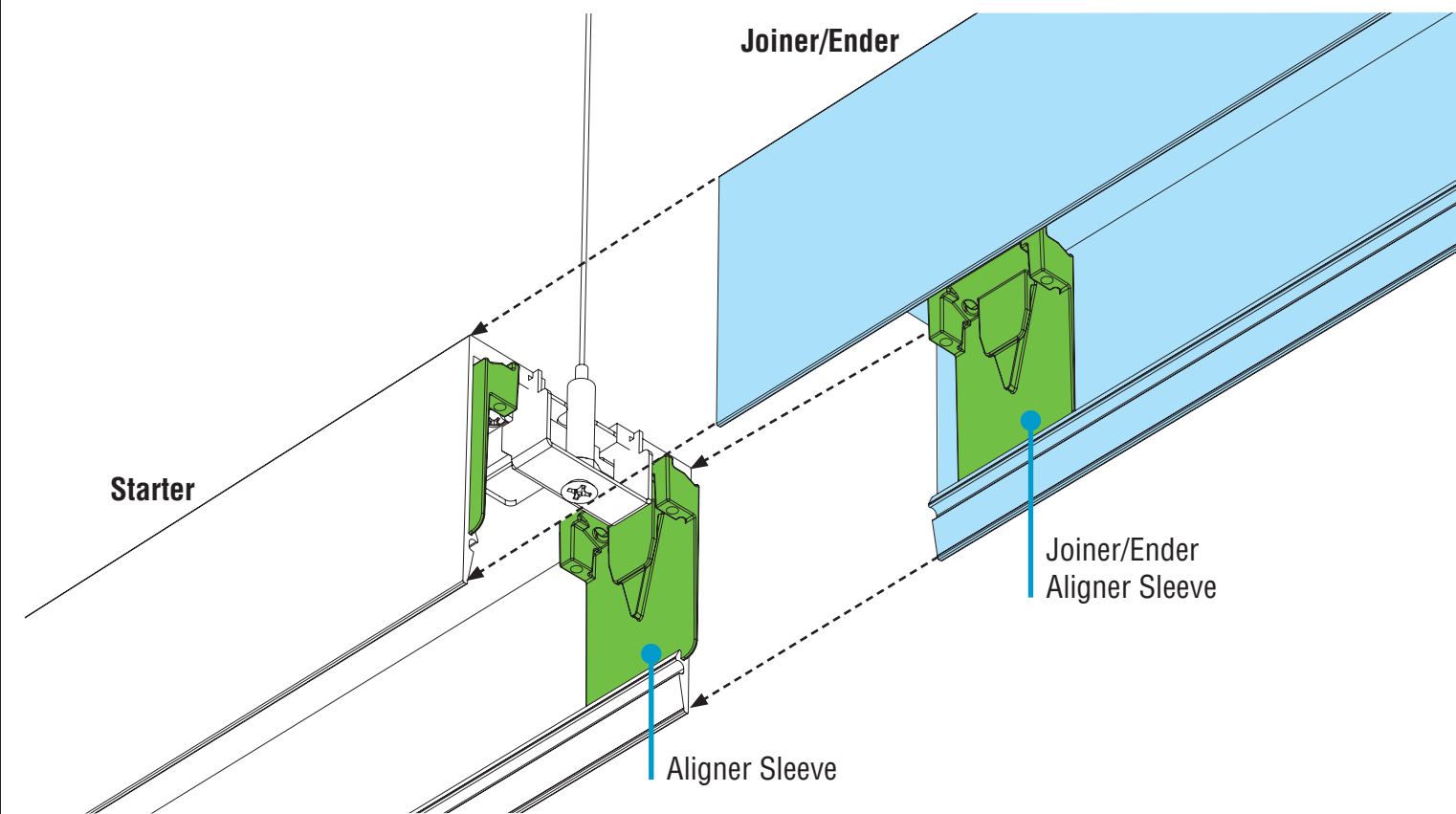

- Align joiner/ender with aligner sleeves on starter and slide together. Be careful not to damage any wiring.
- If necessary, **lift** both luminaires, then slide together.

#### Mounting Option 1 (shown)



3-1/2" Canopy (provided)

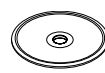

2" T-Bar Support Canopy (provided)

#### Mounting Option 2

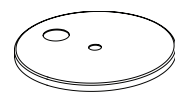

5" Canopy (provided)

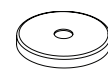

2" Drywall Support Canopy (provided)



Slip Ring w/ Set Screw (provided)



Bushing/Cable Assembly (provided)

# HP-4 Wall Wash Direct Installation Instructions

## Step 6 - Securing Luminaire Joints

### A. Secure Joint with Yoke Brackets

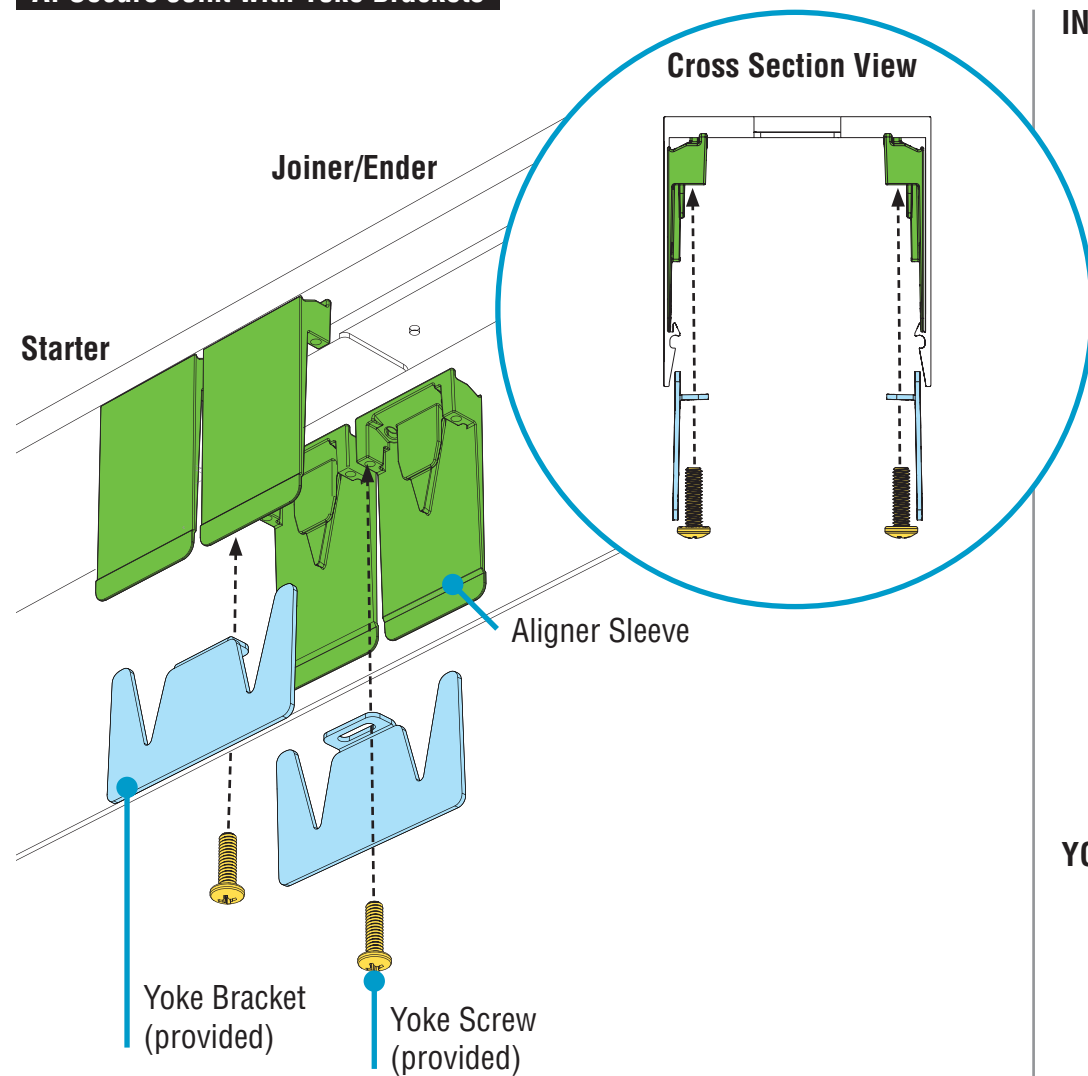

- Before installing yoke brackets, ensure the joining ends of luminaires meet flush and square.
- **CRITICAL:** Ensure yoke brackets properly engage with aligner sleeves.
- Secure joint by threading (but not yet tightening) yoke screws through yoke brackets and into the aligner sleeves.
- Tighten yoke screws<sup>1</sup> until joint seam of luminaires is closed.

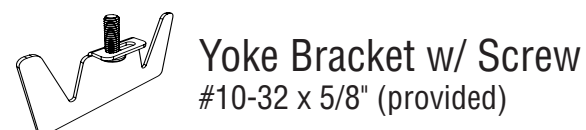

<sup>1</sup> Screwdriver with 6" bit required.

### IN ALIGNMENT

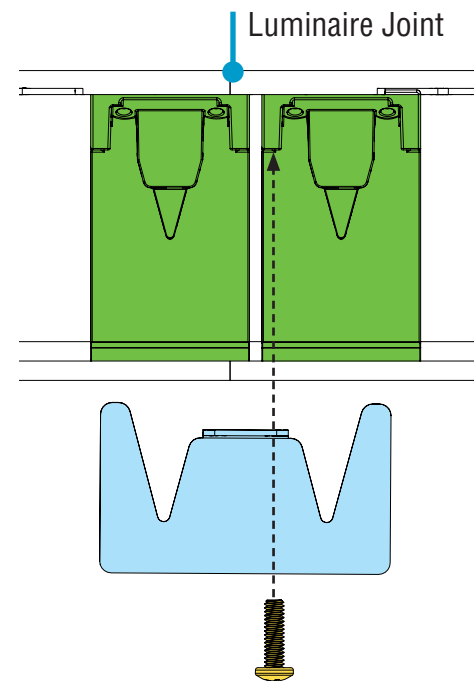

### YOKE SCREW ALIGNMENT Bottom-Up View

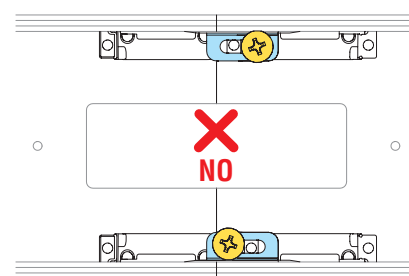

### CORRECTLY INSTALLED

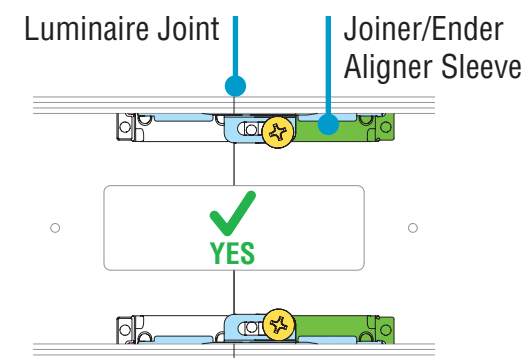
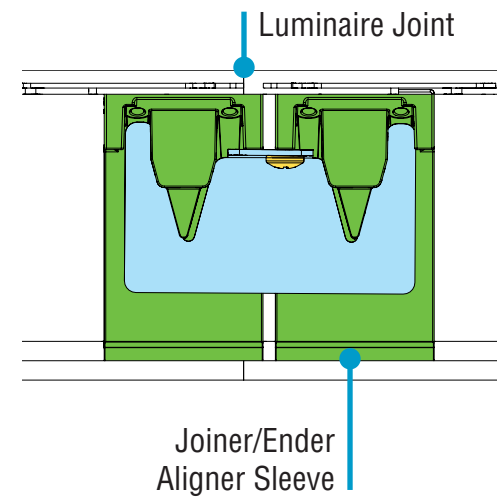

**NOTE:** Yoke screws should be installed directly across from each other, not diagonally, and in holes furthest from the joint line. One yoke screw per one yoke bracket.

### B. Make Electrical Connections

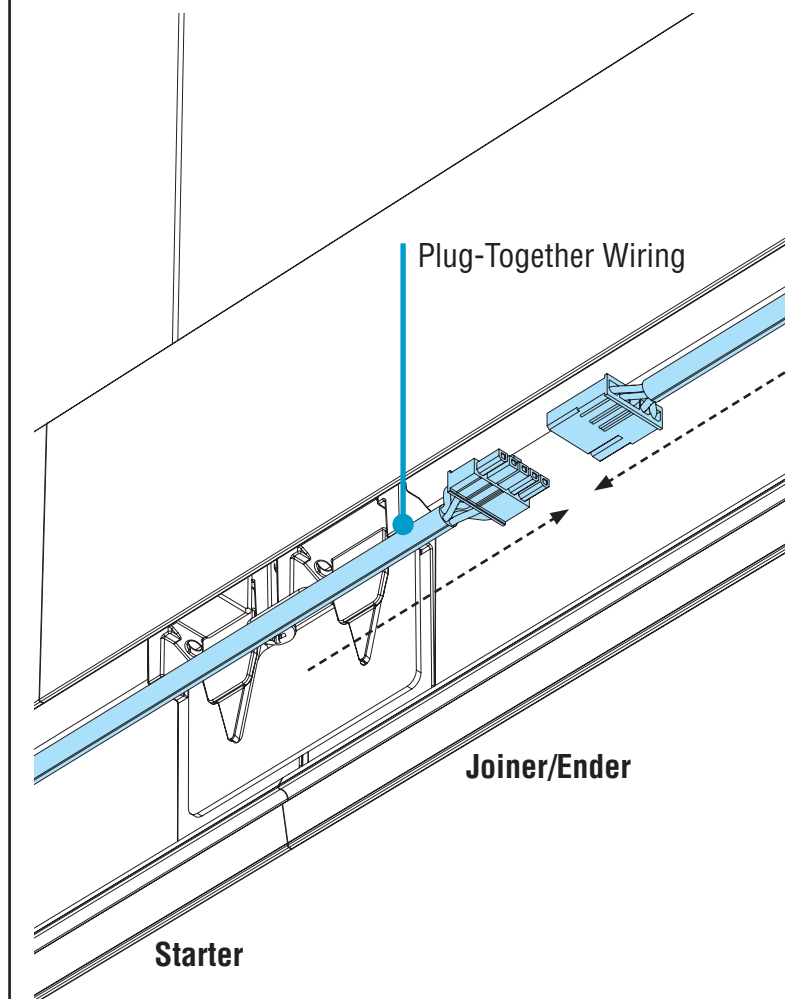

- Connect plug-together wiring.



# HP-4 Wall Wash Direct Installation Instructions

## Step 7 - Closing Luminaires

### A. Crimp Cables

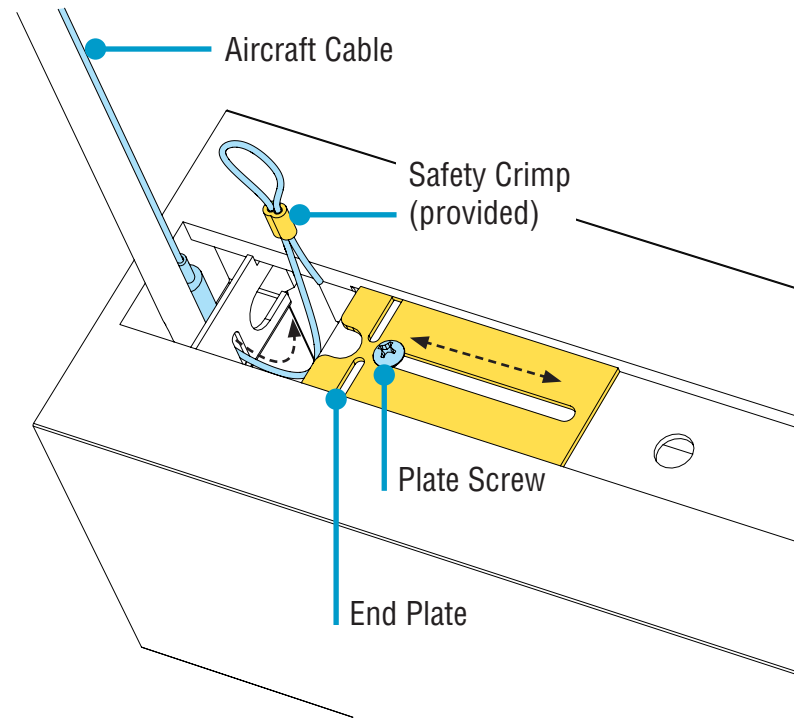

- Ensure all leveling has been performed prior to applying safety crimp.
- Loosen (**but do not remove**) plate screw and slide end plate open.
- Loop aircraft cable through safety crimp.
- Crimp, cut excess cable, and tuck back into luminaire body.
- Close end plate and tighten plate screw to secure. Typical for each aircraft cable.

### B. Replace Backplates

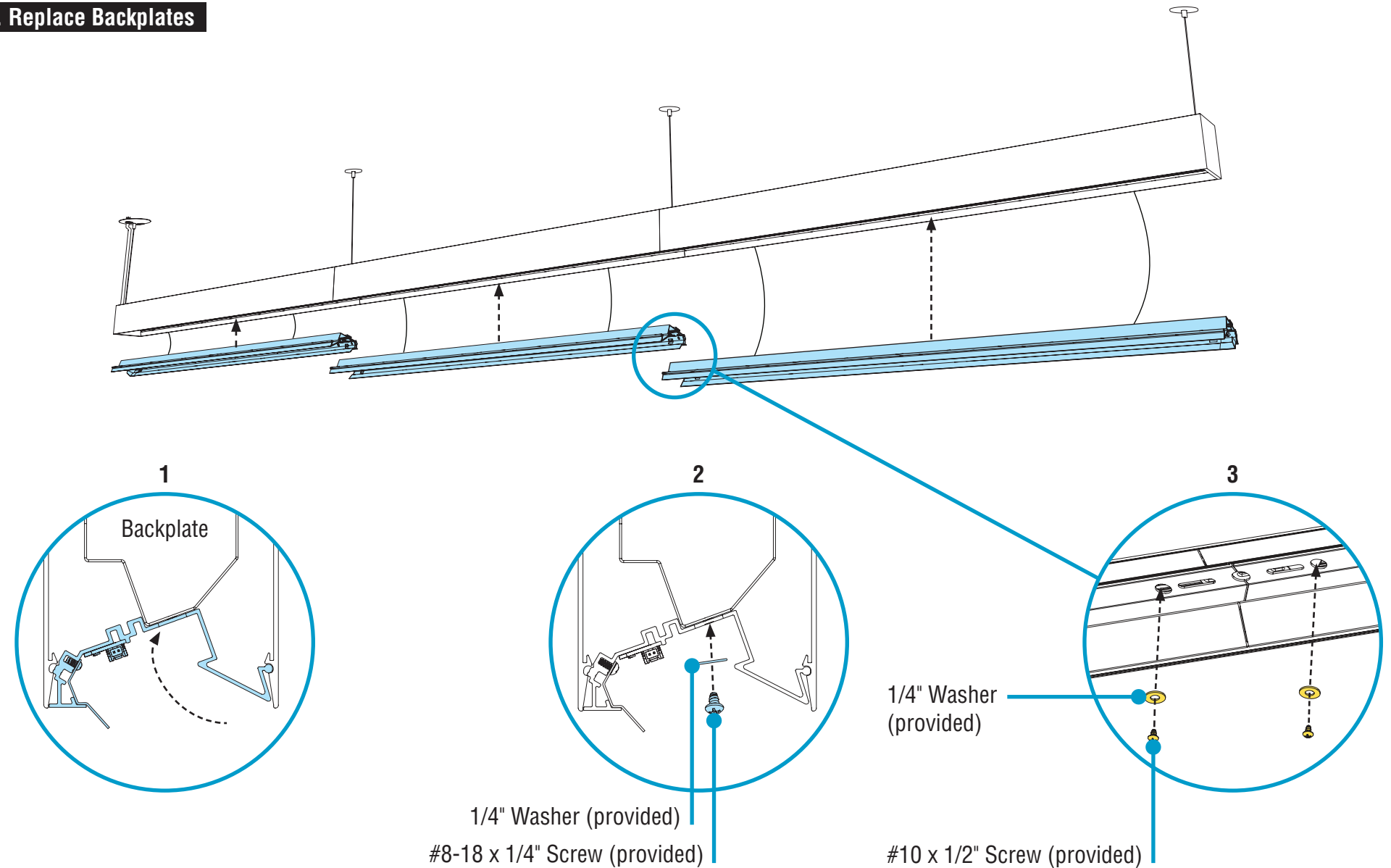

- 1. Carefully reinstall backplate into luminaire by inserting and rotating.
- 2. Install 1/4" washer and #8-18 x 1/4" screw to backplate at both ends of the luminaire.
- 3. Install 1/4" washers and #10 x 1/2" screws at the joint.

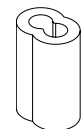

Safety Crimp  
(provided)



#10 x 1/2" Screw  
(provided)



#8-18 x 1/4" Screw  
(provided)



1/4" Washer  
(provided)



# HP-4 Wall Wash Direct Installation Instructions

## Step 7 - Closing Luminaires

**C. Final Step - Replace Diffusers**

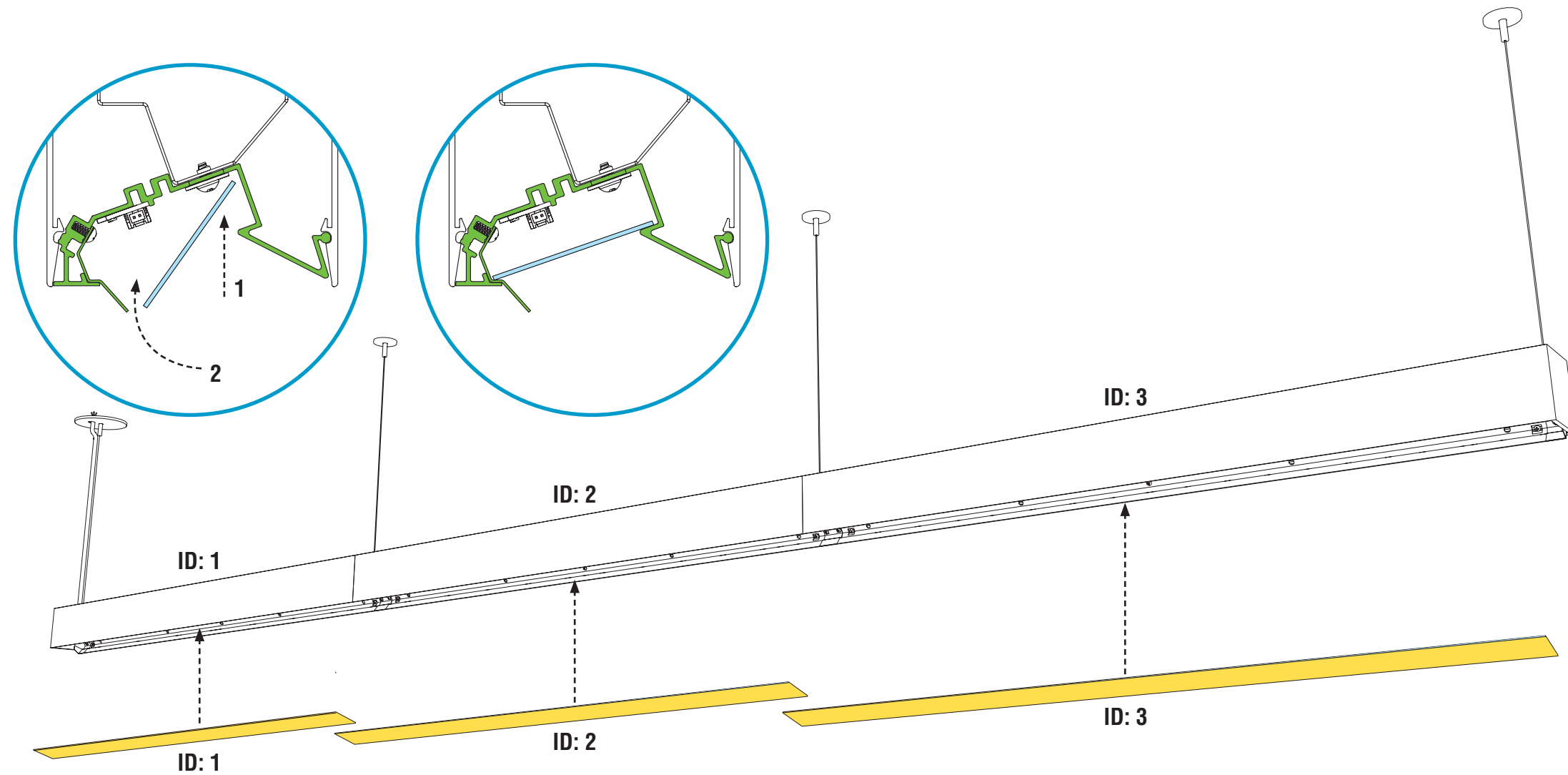

- **NOTE:** If your installation includes a battery backup, please see addendum (98333) that should be included with your kitting package.
- Remove diffusers from protective plastic bag.
- **CAUTION:** Wear gloves to keep diffuser surface clean.
- **CRITICAL:** Be sure to install correct diffuser to its corresponding luminaire ID.
- Install diffusers into luminaire body, ensuring they are in place.
- **1.** Reinstall diffusers by pushing right side of the diffuser into the backplate.
- **2.** Push the left side of diffuser until it lays flat on the backplate.
- Turn power on to luminaire.