

HPT 2'x2' Pendant Installation Instructions

Overview

NOTES

- All power connections should be installed according to local/national codes by a Certified Electrician.
- This installation requires **proper support** as each luminaire is being installed.



HELPFUL
VIDEO



0-10V
Dimming

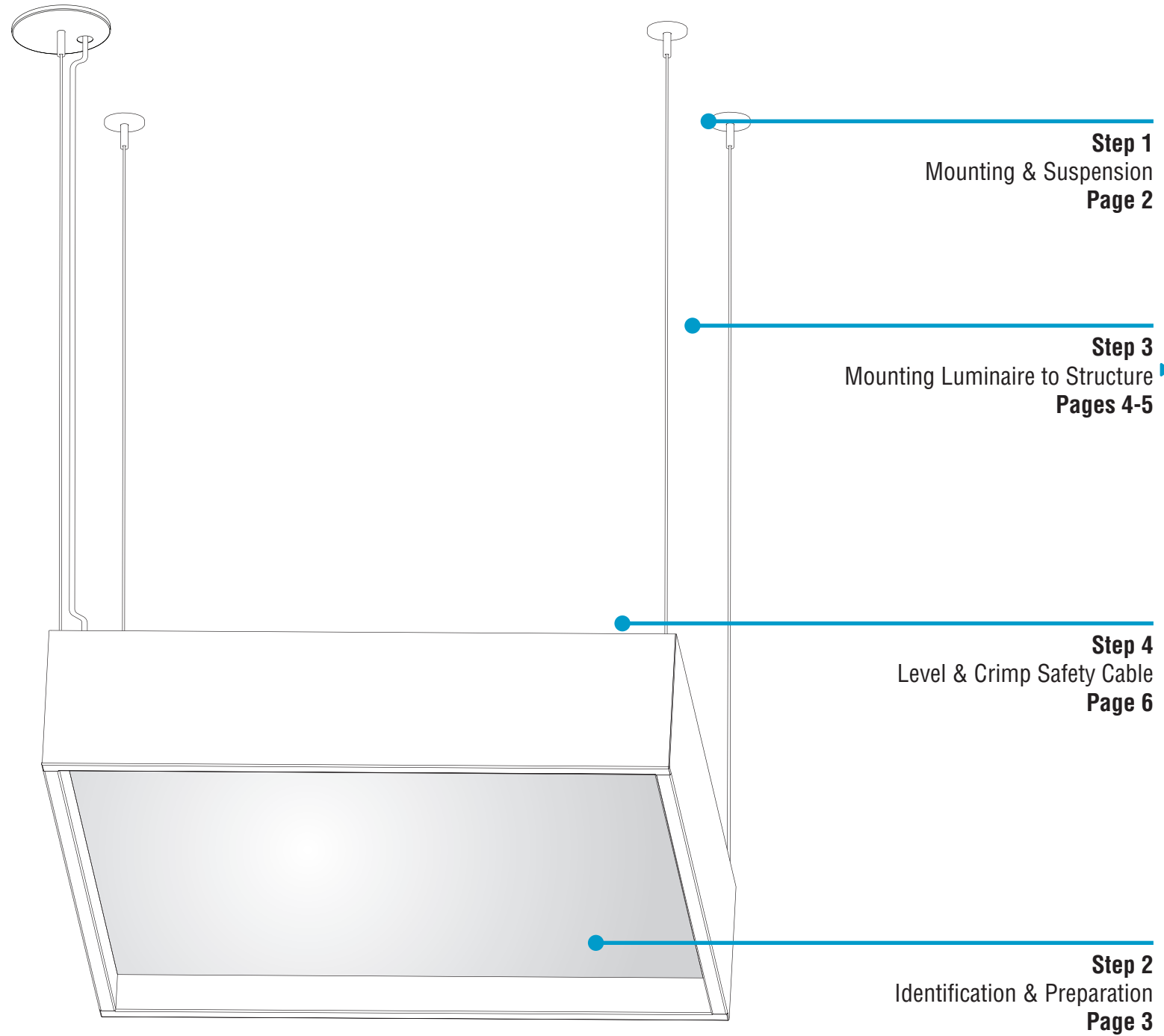

HPT 2'x2' Pendant Installation Instructions

Step 1 - Mounting & Suspension

Mounting Options Top-Down View

Option 1 T-Bar Off-Grid Mounting J-Box and appropriate 1/4" - 20 Fastener

- Locate power feed on luminaire.
- Install J-Box and electrical conduit at feed location.
- Install appropriate 1/4"-20 fasteners at mounting point locations.
- All appropriate 1/4"-20 fasteners are to be secured to structure, per local building codes.

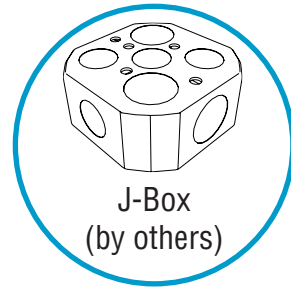

Option 2 Drywall (C4) or other hard surfaces* J-Box and Anchor Bolts

- Locate power feed on luminaire.
- Install J-Box and electrical conduit at feed location.
- Install anchor bolts at mounting point locations.
- All anchor bolts are to be secured to structure, per local building codes.

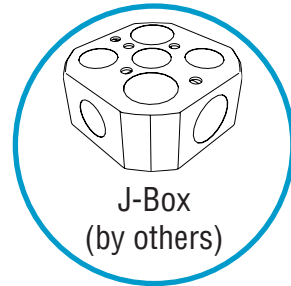

*Other hard surfaces include: wood, sheet metal panels, steel beams, concrete or masonry. Use hardware appropriate for each surface material type.

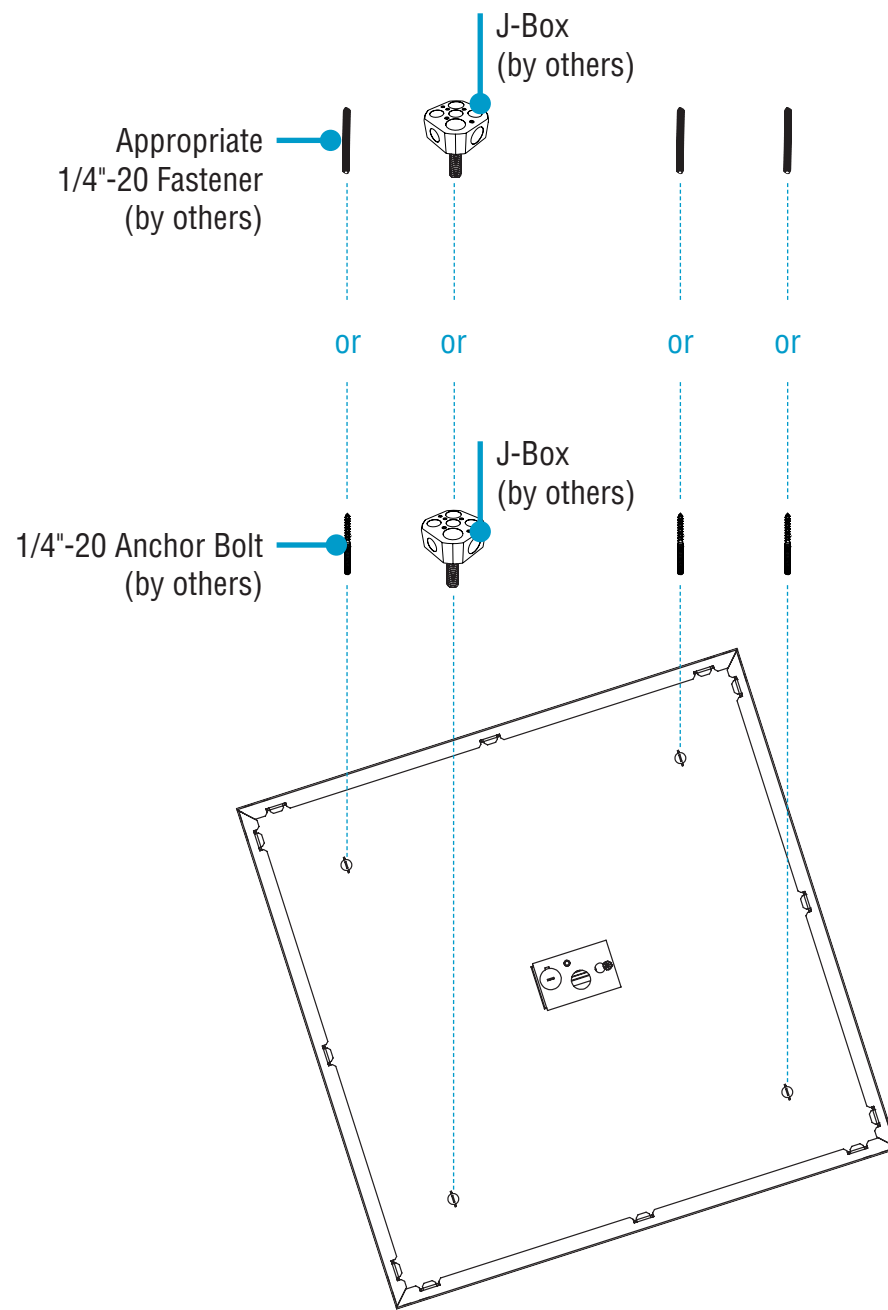

Suspension Points Top-Down View

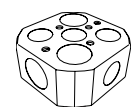
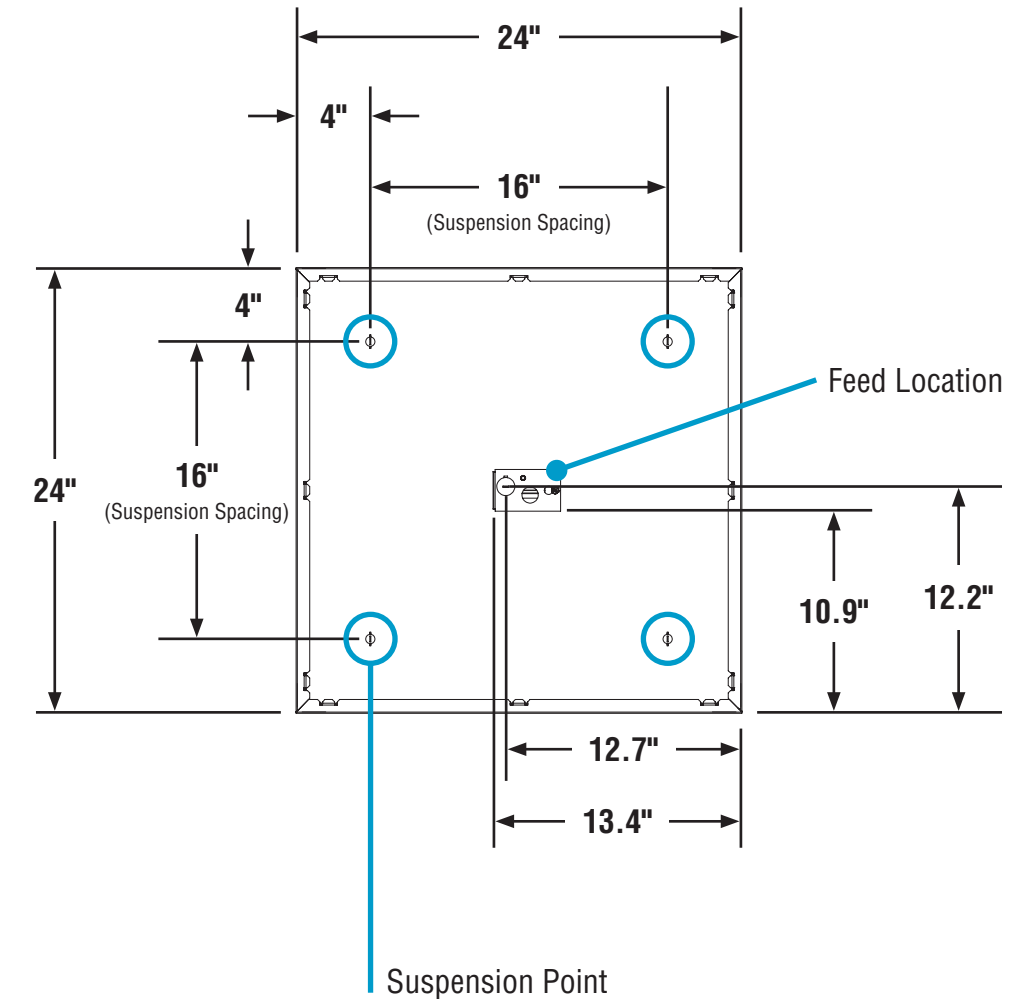

J-Box
(by others)



1/4"-20 Anchor Bolt - Hard Surface
(by others)

or



1/4"-20 Fastener - T-Bar Off-Grid
(by others)

HPT 2'x2' Pendant Installation Instructions

Step 2 - Identification & Preparation

Identify Luminaire



Arrange luminaires in order according to ID# at their install locations.

CAUTION

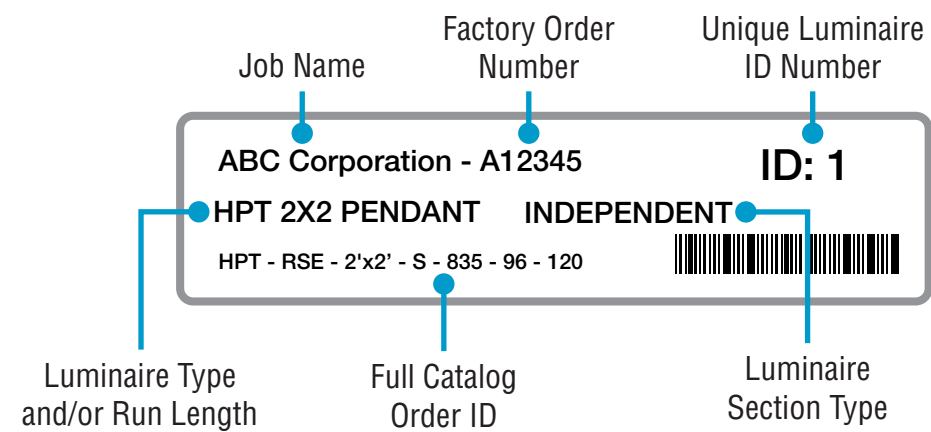

- Identify all luminaires by their ID label that can be found on the box and inside the luminaire.
- **NOTE:** Exact location of labels in these areas may vary.
- Remove all luminaires from their box.
- Refer to Record Drawings that can be found in the hardware kit.

Locate ID Label Bottom-Up View



Wear gloves to keep diffuser surface clean.

CAUTION

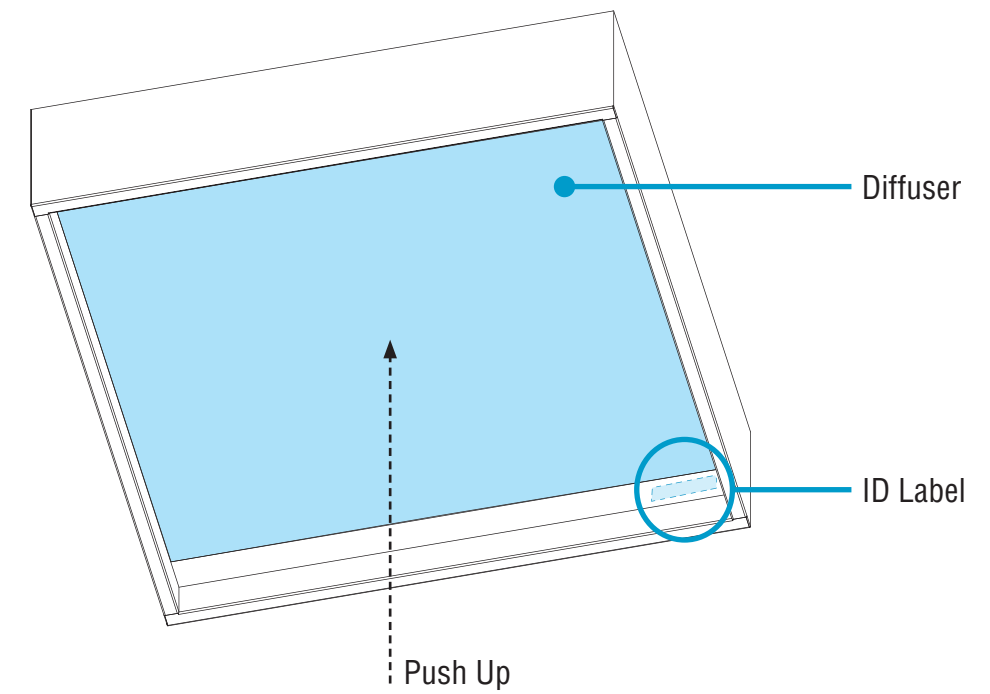

- Push up diffuser to locate ID label inside luminaire.

Kitted Hardware

- Finelite has provided items listed here, with their Finelite part numbers. These items can be found in separate boxes shipped with the luminaire.
- Account for all parts and set aside until they are needed.
- All other hardware needed for this installation will be by others.



5" Canopy
Part# 94085



2" Drywall Support Canopy
Part# 94017
Mounting Luminaire to Structure
p. 4, Step 3



Cable Bushing
Part# 94014

Aircraft Cable
50" - Part# 94515-12 (Std.)
100" - Part# 94515-14
150" - Part# 94515-18
Mounting Luminaire to Structure
p. 4-5, Step 3
Level & Crimp Safety Cable
p. 6, Step 4



Slip Ring w/ Set Screw
Part# 94015
Mounting Luminaire to Structure
p. 4, Step 3



Gripper
Part# 68129
Mounting Luminaire to Structure
p. 4, Step 3
Level & Crimp Safety Cable
p. 6, Step 4

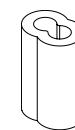

Safety Crimp
Part# 94514
Level & Crimp Safety Cable
p. 6, Step 4

HPT 2'x2' Pendant Installation Instructions

Step 3 - Mounting Luminaire to Structure

A. Install Grippers Top-Down View

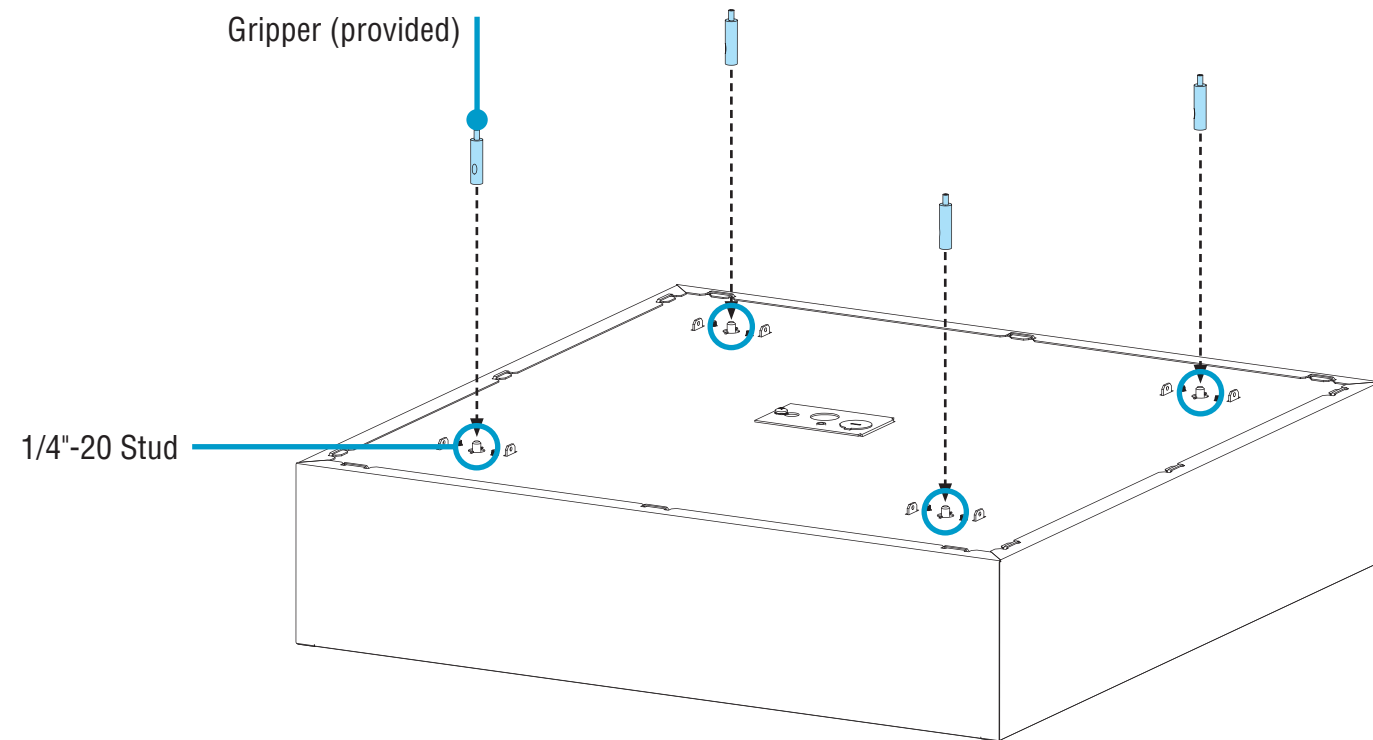

- Install grippers onto 1/4"-20 studs.

B. Mount Luminaire to Structure Bottom-Up View

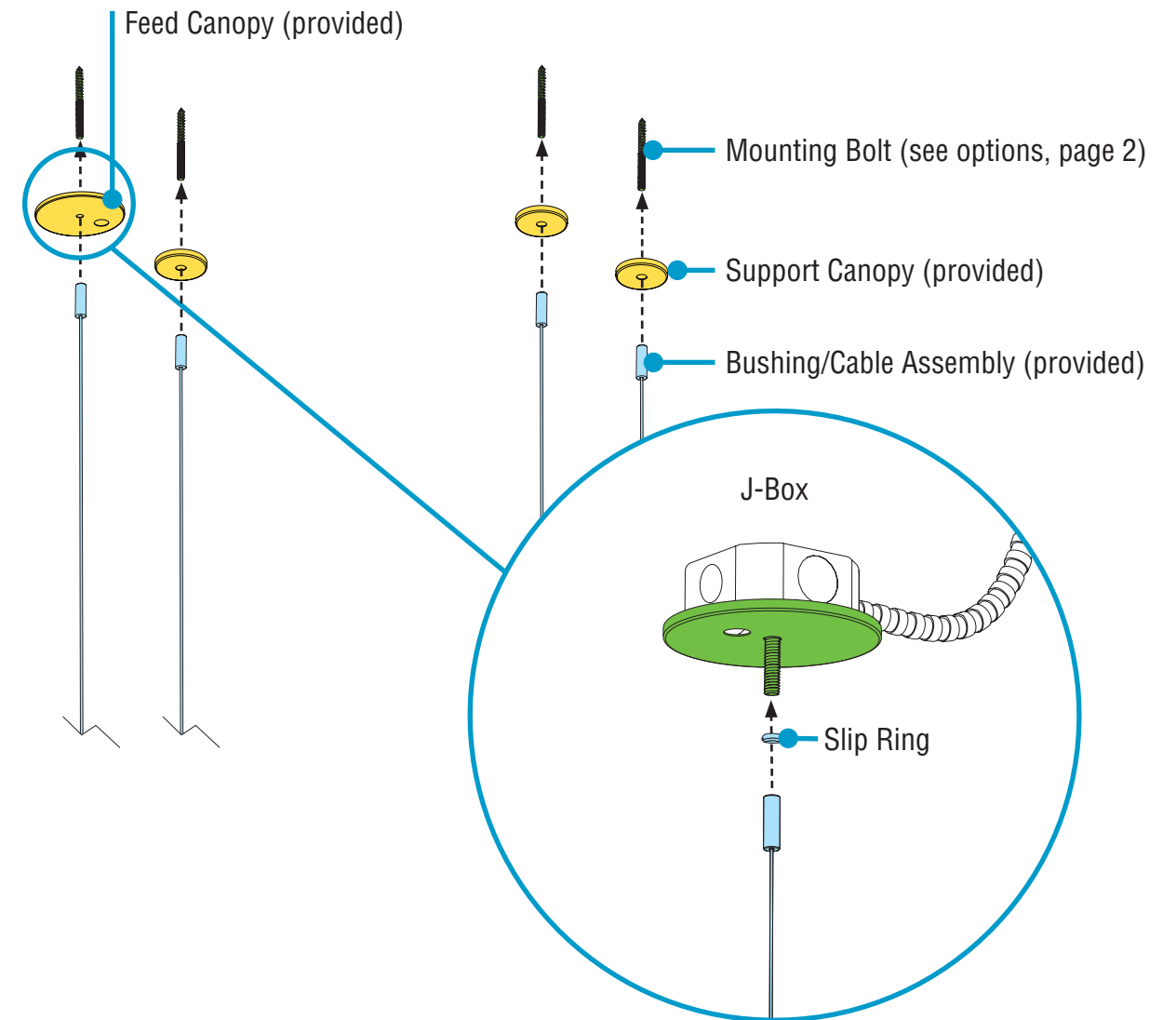

- Slide canopy appropriate for electrical type options onto mounting bolt (anchor bolt or appropriate 1/4"-20 fastener).
- Thread the slip ring onto mounting bolts and secure with set screw at both mounting locations.
- Thread the bushing/cable assembly onto mounting bolts.
- While properly supporting luminaire, maneuver luminaire to ceiling and insert cables into grippers to support luminaire from the ceiling.

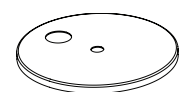

5" Canopy
(provided)

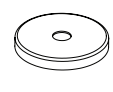

2" Drywall Support Canopy
(provided)



Bushing/Cable Assembly
(provided)



Gripper
(provided)



Slip Ring w/ Set Screw
(provided)

CONTINUED

HPT 2'x2' Pendant Installation Instructions

Step 3 - Mounting Luminaire to Structure

C. Make Electrical Connections Bottom-Up View

WIRING LEGEND		
Black	Hot	Line Voltage
White	Neutral	Line Voltage
Green	Ground	
Pink	Dimming	0-10V DC
Purple	Dimming	0-10V DC

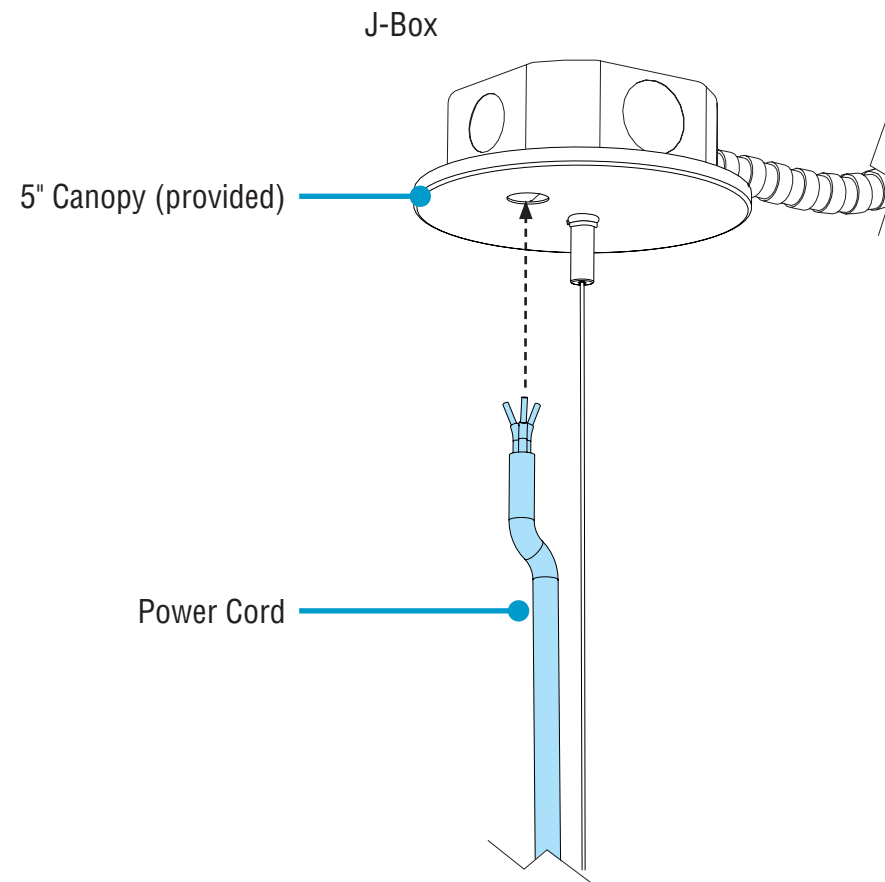

Feed power cord through the 5" canopy and connect wires inside the J-Box.

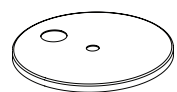

5" Canopy
(provided)

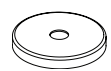

2" Drywall Support Canopy
(provided)



Slip Ring w/ Set Screw
(provided)



Bushing/Cable Assembly
(provided)



0-10V
Dimming

HPT 2'x2' Pendant Installation Instructions

Step 4 - Level & Crimp Safety Cable

A. Level & Crimp Safety Cable Top-Down View

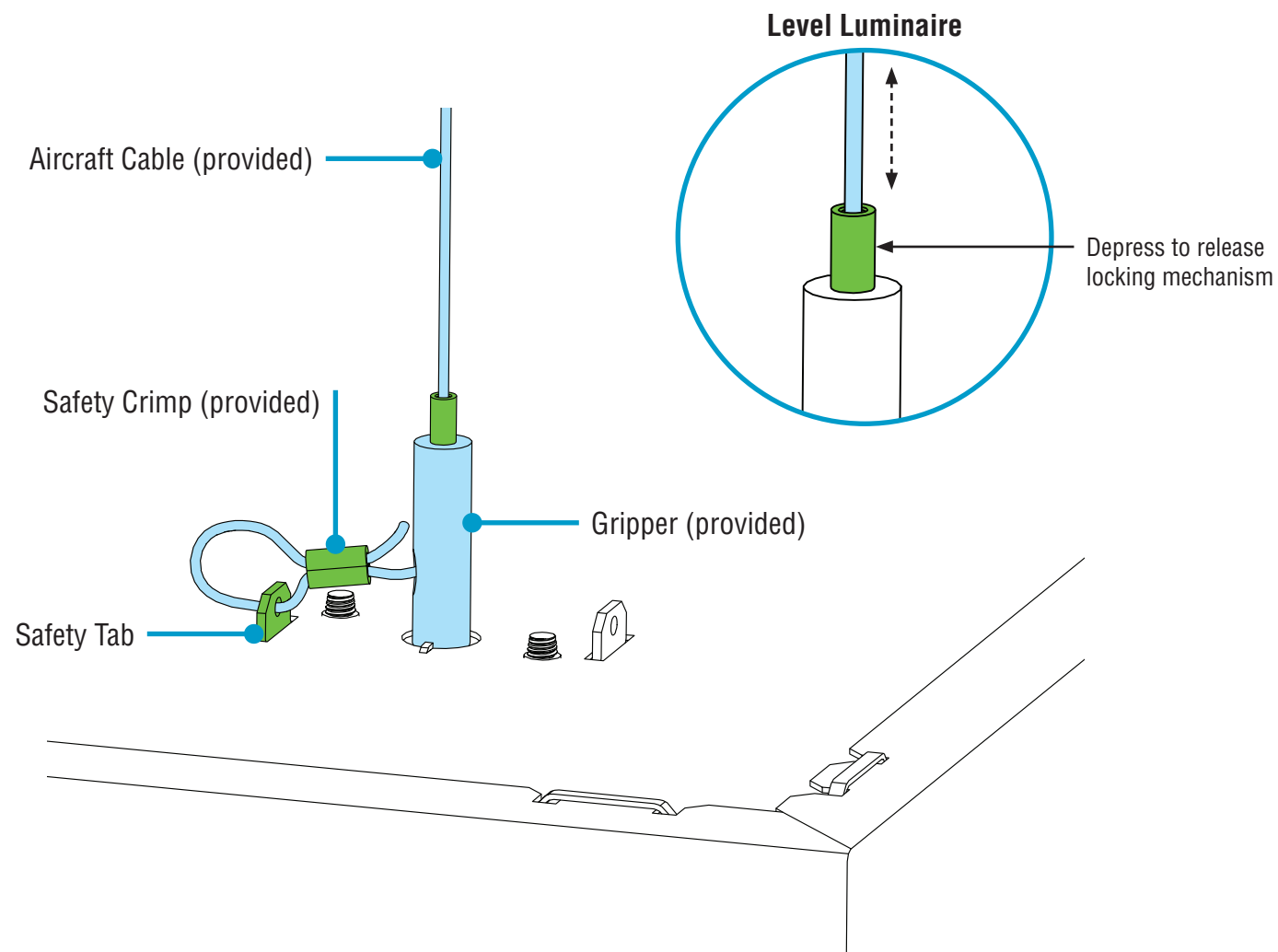

B. Final Step - Remove Protective Film Bottom-Up View

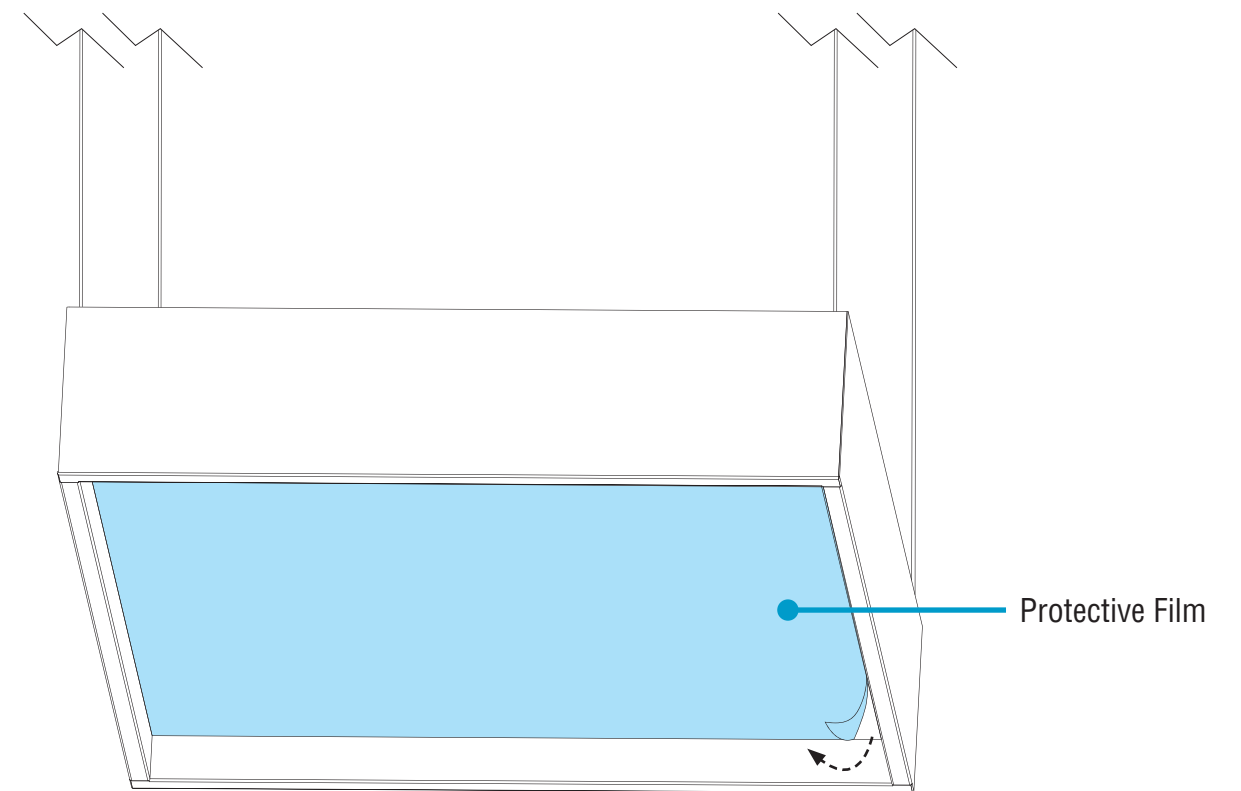

- **CRITICAL:** Ensure all leveling has been performed by depressing top of grippers to adjust cable lengths prior to applying safety crimp.
- Run aircraft cable through safety crimp and safety tab, make a loop, and then run aircraft cable back through safety crimp.
- **NOTE:** Either safety tab may be used.
- Crimp and cut excess aircraft cable to lock in place. Typical for each aircraft cable.

- Remove protective film carefully.
- Turn power on to luminaire.

