

# FINELITE High Performance Recessed (HPR) 2x2 Surface Mount

Date

Project

Type

Comments

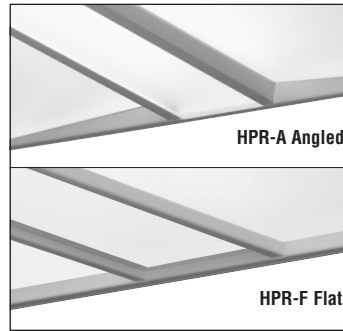
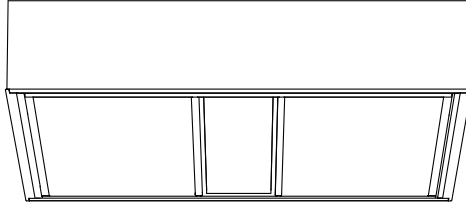

## DESCRIPTION

High Performance Surface Mount is a highly effective luminaire delivering excellent visual comfort and outstanding performance for office, school, healthcare, and retail applications. Advanced optical designs make HPR a powerful solution for low-ceiling applications and eliminate the shadows common to other products.

### Diffuse (DCO) Slotted (SCO) Round (RCO)

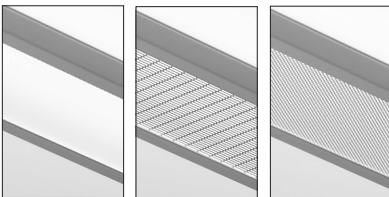

### CENTER SHIELDING OPTIONS:

HPR is available with three different center-shielding options: a diffuse center optic, a slotted center optic, and a round center optic.

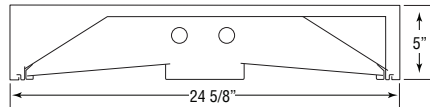

T8 (1, 2, or 3)

T5 / T5HO (1, 2, or 3)

### DIMENSIONS / LIGHT ENGINE:

Available in 1, 2, or 3 T8, T5 or T5HO lamps.



### INTEGRATED SENSORS:

HPR can be specified with integrated daylight or occupancy sensors.

## ORDERING GUIDE

Sample Number: HPR - F - 2x2 - DCO - 1T8 - 277 - SC - SM - IS.88 - OBO

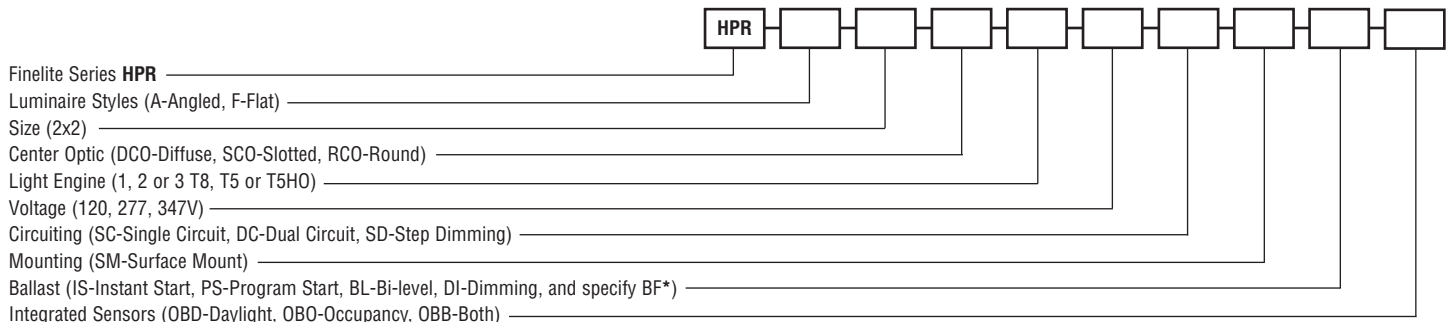

\* Standard .88 for T8 lamps, 1.0 for T5 or T5HO. Contact factory for available BF's  
Contact factory for Master/Satellite options.

# FINELITE

## High Performance Recessed (HPR) 2x2 - Surface Mount

### WIRING ACCESS DETAIL

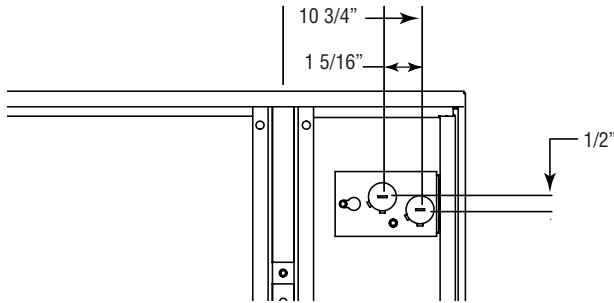

### MOUNTING INFORMATION

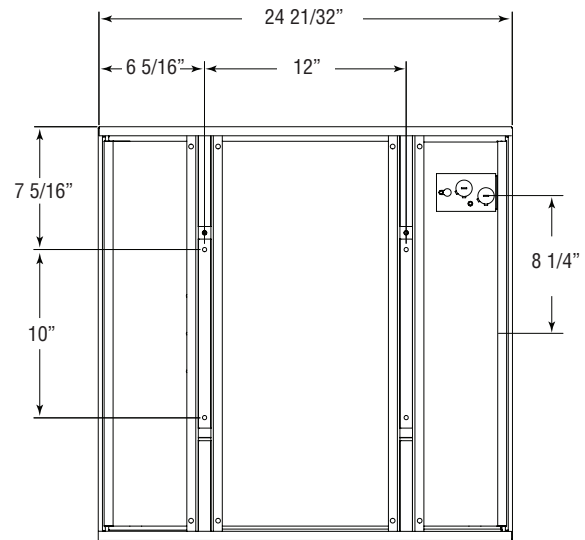

### SPECIFICATIONS

**CONSTRUCTION:** Fixture assembly constructed using die-formed 20-gauge cold-rolled steel housing and ends. All components are hard-tooled to tolerances of 0.010". Ballast compartment is accessed from below. Optical system retained using hinged door frame assembly to provide easy access to ballast compartment and for re-lamping from below without the need of tools.

**REFLECTORS:** Die-formed 20-gauge cold-rolled steel reflectors are finished in 96 LG high reflectance matte white powder coat paint.

**OPTICAL SYSTEM:** Optical system components include side lens panels and a center optic element held in place with a frame constructed from die-formed cold-rolled steel. The side lenses are UV-stabilized and impact-resistant frosted virgin acrylic .080 thick. They are either angled toward the center optic or parallel to the ceiling plane.

*Available options for the center optic elements:*

*Diffuse Center Optic: UV-stabilized and impact-resistant frosted virgin acrylic. Optional Soft Glow Optic (SGO) available for T8 only.*

*Slotted Center Optic: Die-formed cold-rolled steel panel with 1/16" x 1/2" rectangular hole pattern. Virgin acrylic overlay.*

*Round Center Optic: Die-formed cold-rolled steel panel with precision-punched 3/32" round hole pattern arranged in staggered formation. Virgin acrylic overlay.*

**LIGHT ENGINE:** Available in 1, 2, or 3 T8, T5, or T5HO lamp cross sections. Available in 1 or 2 lamp FT40W, FT50W, or FT55W high lumen TT5 cross sections.

**BALLAST:** UL listed Class P. Electronic instant-start ballast <10% THD, 0.88 BF standard for T8 lamps. Electronic rapid-start ballasts <10% THD, 1.0 BF standard for T5/T5HO lamps. Contact factory for available BF's. Optional adders: rapid-start ballasts (standard for T5/T5HO), 347V, emergency battery packs, dimming or bi-level ballasts (controls by others).

**ELECTRICAL:** Fixtures and electrical components are ETL listed conforming to UL1598 in the USA and Canada, and ETL listed certified to CAN/CSA C22.2 No. 250.0. In accordance with NEC code 410.73 (G) this luminaire contains an internal ballast disconnect.



**INTEGRATED SENSORS:** Refer to Occupancy Sensor and Daylight Sensor tech sheets for more info.

**MOUNTING:** Fixture is compatible with recessed junction boxes. Electrical connections can be made directly to wiring access plate shown above. Junction boxes can also be placed between mounting bars. Maximum center of feed location from luminaire center is 8 3/4" along the dimension parallel to the mounting bars, and 14" along dimension perpendicular to the mounting bars.

**FEED:** 18-gauge straight cord.

**FINISH:** Housing and door assembly painted with 96 LG high reflectance matte white powder coat paint. Available in matte white only.

**WIRING:** Master / Satellite wiring available. Contact factory for configuration options. Optional whips (with flex connectors) supplied in a max. of 11' lengths.

**WEIGHT:** Maximum weight: 2x2 - 24 lbs.