

# FINELITE

## Series X2 Joining Instructions - (Semi-Adjustable Cable Shown)

DO NOT attempt to join fixtures together on the floor. Damage may result when lifted. Follow these instructions.

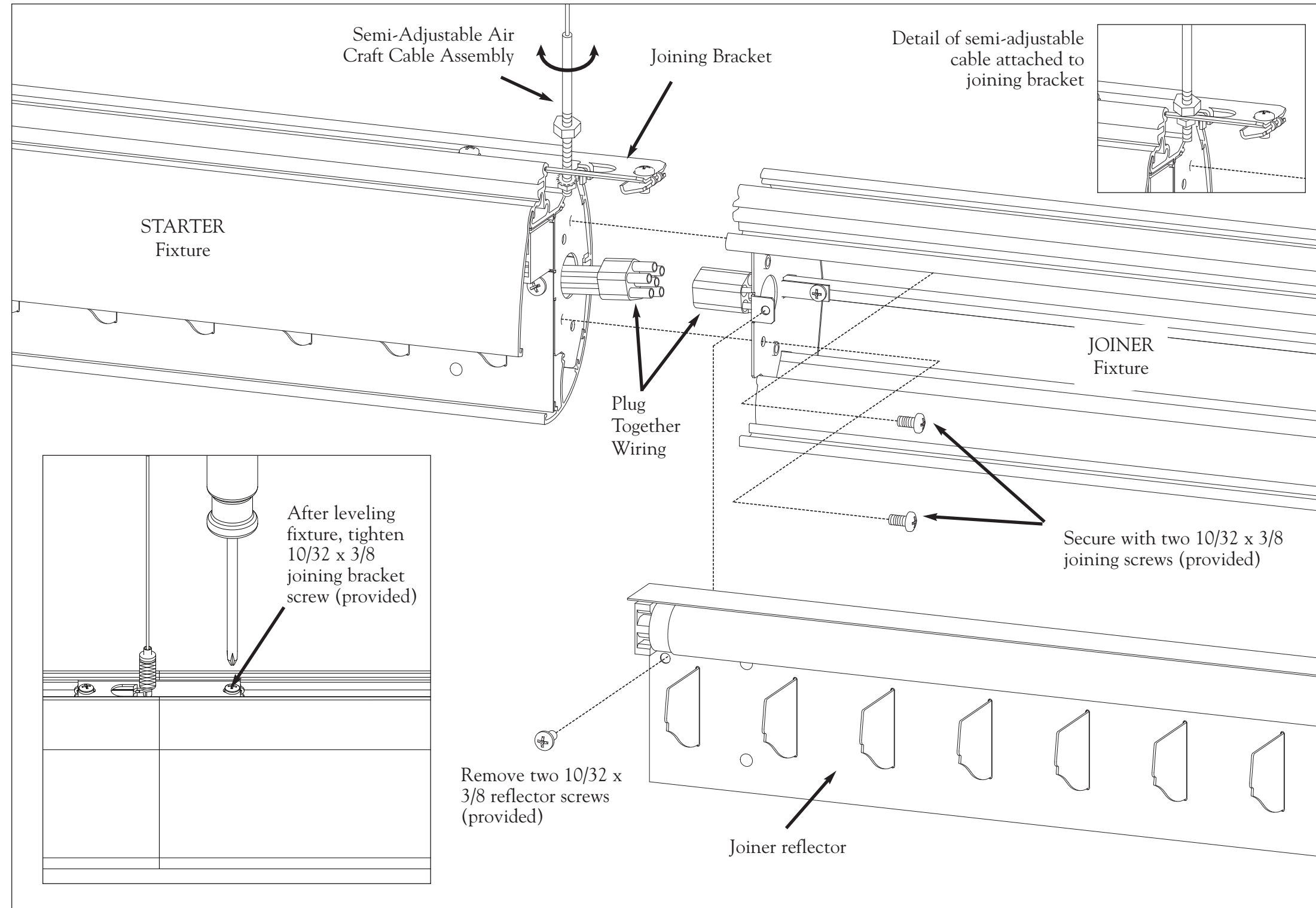

### JOINING INSTRUCTIONS

- STEP 1:** Hang STARTER fixture as described in the "Starter/Independent" instructions.
- STEP 2:** Hang far end of JOINER while supporting both ends. Remove reflector of JOINER by removing (2) 10/32 x 3/8 screws.
- STEP 3:** Connect plug together wiring and insert into cavity being careful not to pinch any wires.
- STEP 4:** Slide JOINER onto bracket and secure with (2) 10/32 x 3/8 joiner screws (provided) as shown. Level as necessary to match position of STARTER. Tighten bracket to JOINER by tightening screws.
- STEP 5:** Replace reflector and insert lamp