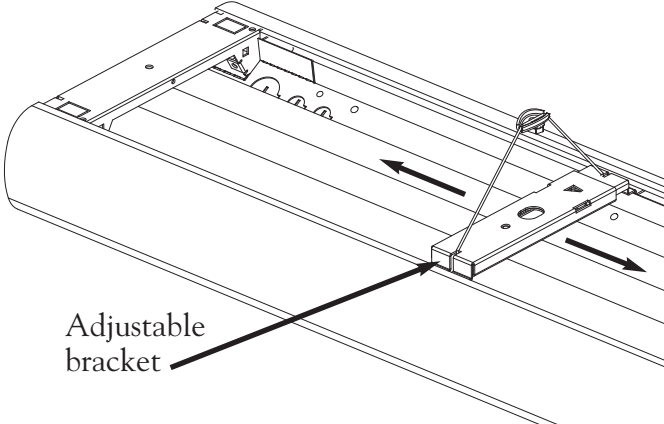
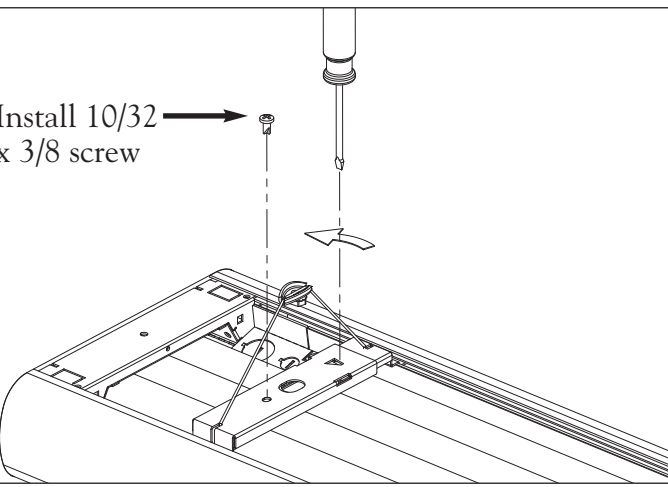
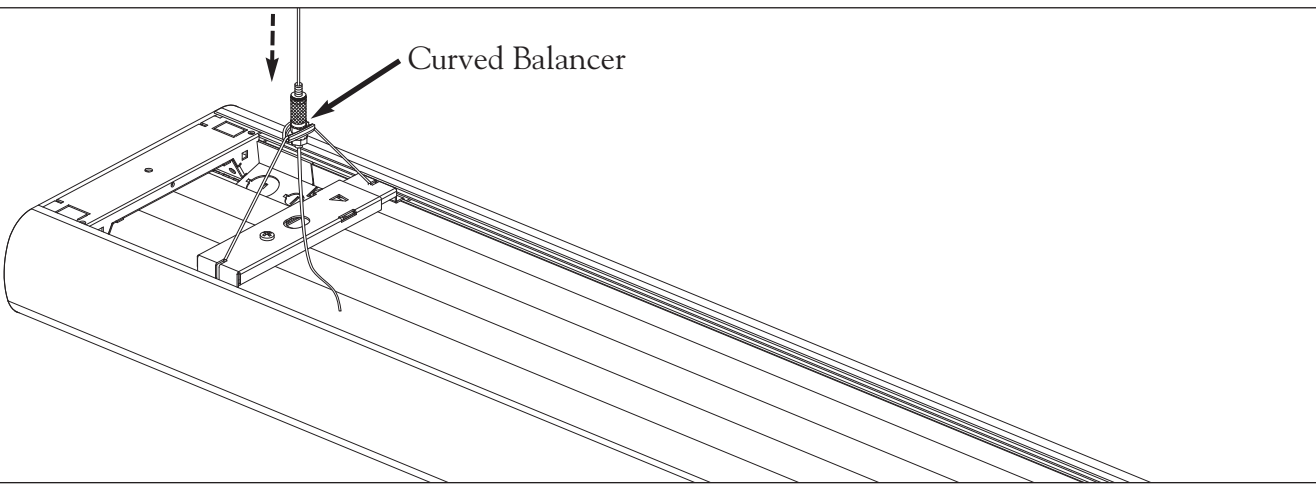
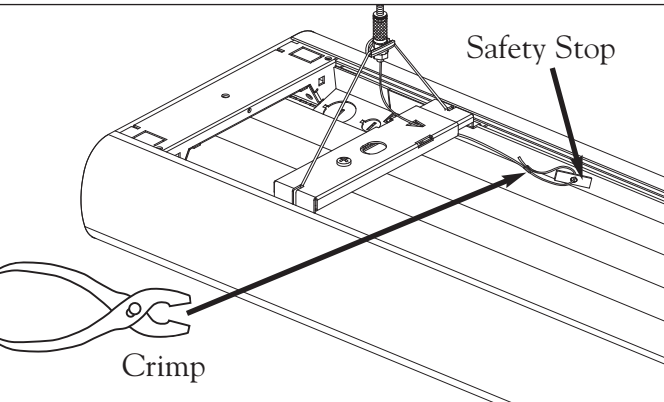
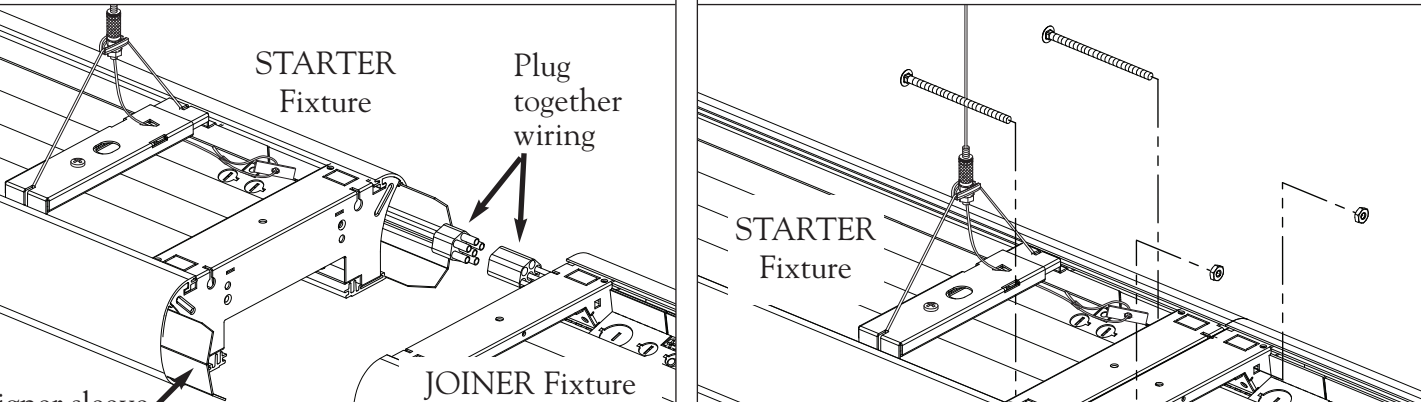
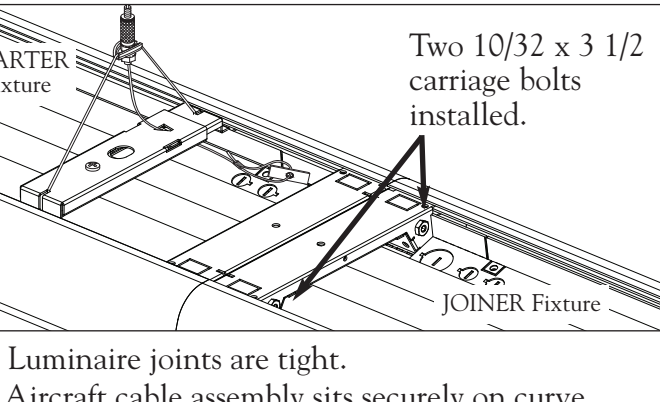
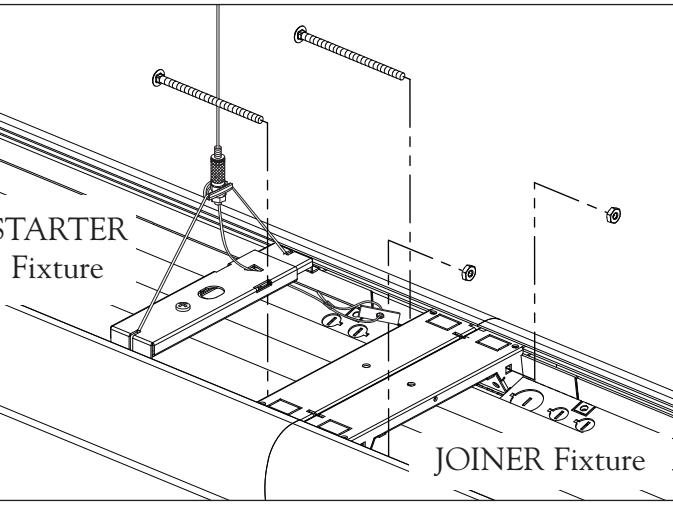

FINELITE

Series X1 Flexible Mount Instructions

DO NOT attempt to join fixtures together on the floor. Damage may result when lifted. Follow these instructions.

<p>POSITION ADJUSTABLE BRACKET</p> 	<p>LOCK ADJUSTABLE BRACKETS</p> 	<p>ADJUST AND LEVEL</p> 	
<p>1. Brackets slide freely in the body until locked into place. Position bracket in desired location.</p>	<p>2. Once the adjustable brackets are in location, insert a screwdriver in the slot indicated above. The screw hole will open up. Insert and tighten screw (provided), locking bracket in place.</p>	<p>3. Position the adjustable cable gripper over the curve balancer, turn to engage threads. Move slider for side-to-side leveling. Lock by turning cable gripper securely until serrated kep nut fits tightly against slider.</p>	
<p>SECURE AND TRIM</p> 	<p>JOINING LUMINAIRES</p> 		<p>FINAL CHECK</p> 
<p>4. Unscrew release lock nut and depress to adjust cable height, turn to lock. Thread cable through hole in adjustable bracket as shown above, attach safety stop, crimp and trim excess cable. MAKE SURE THAT NO METAL MAKES CONTACT WITH THE LAMPS.</p>	<p>5. Hang far end of JOINER fixture while supporting both ends. Connect plug together wiring between STARTER and JOINER fixtures. Slide JOINER onto aligner sleeves. Tuck plug together wiring into channel being careful not to pinch any wires.</p>		<p>7. - Luminaire joints are tight. - Aircraft cable assembly sits securely on curve balancer, nut is tight. - Plug together wiring is connected and no wires have been pinched. - Safety stop is secured and in place. - Two carriage bolts have been installed in between fixtures.</p>
<p>SECURING JOINTS</p> 		<p>6. Two carriage bolts are provided to secure luminaires together. Insert bolts where shown and secure with nuts (provided).</p>	