

# FINELITE

## Series 6C Instructions Fully Adjustable Cable

### ADJUST & LEVEL (endcap detail)

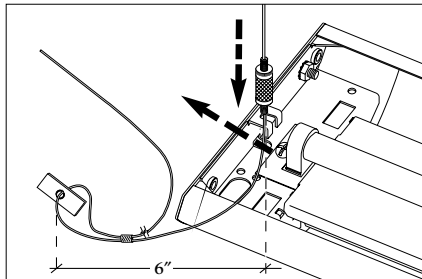

1. Position the serrated keps nut of the adjustable cable gripper under the mounting hooks, rotate up to sit securely on top of hook. Finger tighten keps nut until secure. (Avoid over-tightening.) Depress Release Lock Nut to adjust A/C, relock to secure.

### SECURE & TRIM (endcap detail)

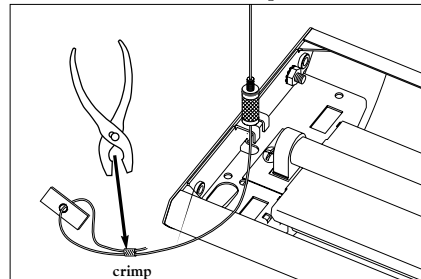

2. Slide Safety Stop and Safety Crimp up cable to within 6" of cable gripper. Secure Safety Crimp with crimping tool. Trim excess cable. Lower Safety Stop, Safety Crimp and 6" of cable into fixture.

### INSERT TO COMPLETE (joint detail)

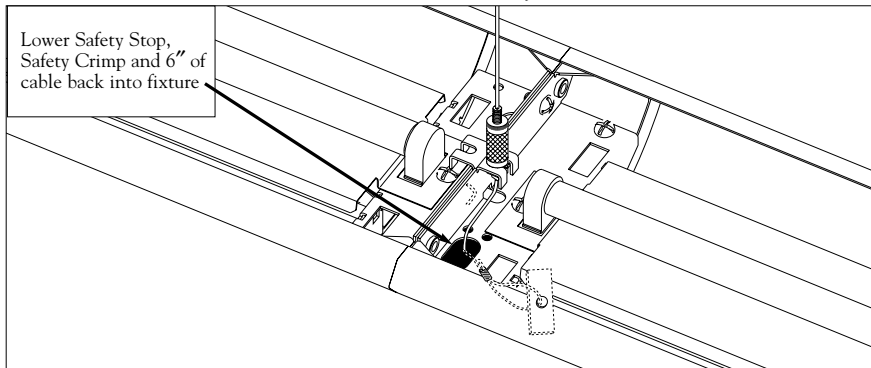

Lower Safety Stop, Safety Crimp and 6" of cable back into fixture

**FINAL CHECK:** In completed installation the Release Lock Nut is screwed down, Keps Nut is tight, crimp has been secured, Safety Stop and Safety Crimp and 6" of aircraft cable are securely inside fixture body.

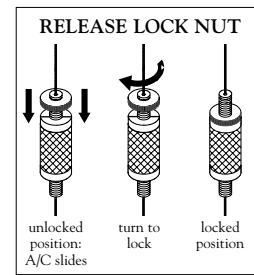

### ADJUSTABLE CABLE GRIPPER ASSEMBLY

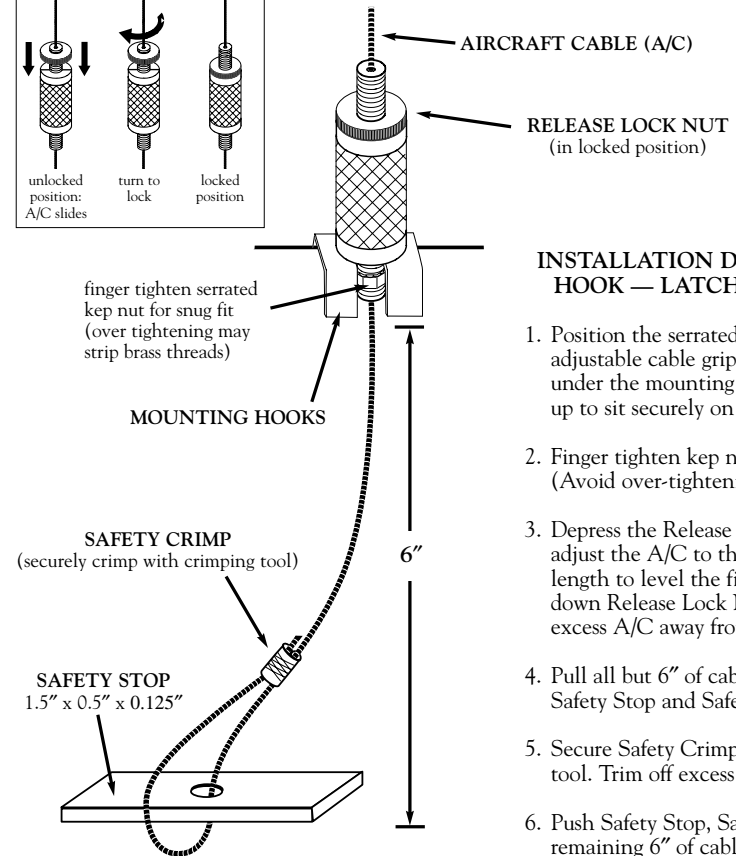

### INSTALLATION DIRECTIONS HOOK — LATCH — LEVEL

1. Position the serrated keps nut of the adjustable cable gripper assembly under the mounting hooks, rotate up to sit securely on top of hook.
2. Finger tighten keps nut until secure. (Avoid over-tightening.)
3. Depress the Release Lock Nut to adjust the A/C to the correct length to level the fixture. Screw down Release Lock Nut. Pull excess A/C away from fixture.
4. Pull all but 6" of cable up through Safety Stop and Safety Crimp.
5. Secure Safety Crimp with crimping tool. Trim off excess cable.
6. Push Safety Stop, Safety Crimp and remaining 6" of cable down into fixture body.

89450 Fully Adjustable Cable Installation Instructions

89450 Fully Adjustable Cable Assembly