

FINELITE

Series 2 Instructions Fully Adjustable Cable

ADJUST & LEVEL (endcap detail)

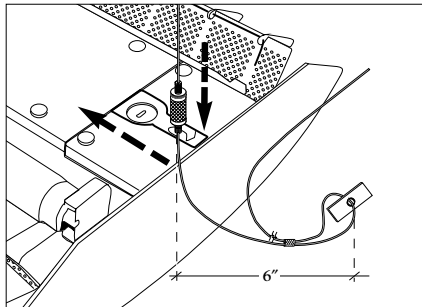

LEFT: Position the serrated keping nut of the adjustable cable gripper under the mounting hooks, rotate up to sit securely on top of hook. Finger tighten keping nut to secure. Depress Release Lock Nut to release A/C and slide Safety Stop and Safety Crimp up A/C cable to within 6" of cable gripper. Turn Release Lock until it stops to relock and secure A/C cable. **RIGHT:** Secure Safety Crimp with crimping tool. Trim excess cable. Continue as described below.

SECURE & TRIM (endcap detail)

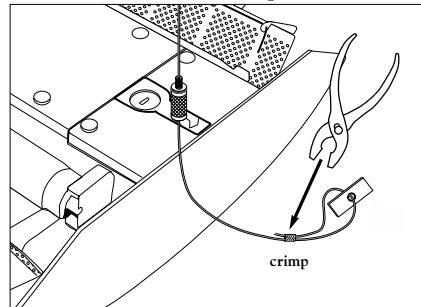

INSERT TO COMPLETE (joint detail)

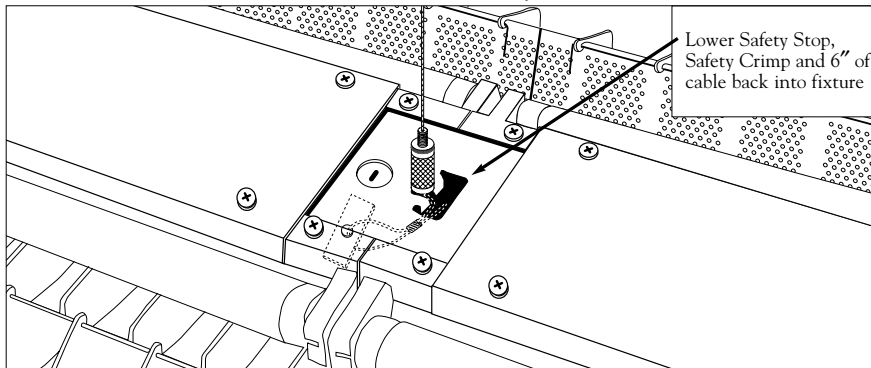

FINAL CHECK: In completed installation the Release Lock Nut is screwed down, Keping Nut is tight, crimp has been secured, Safety Stop and Safety Crimp and 6" of aircraft cable are securely inside fixture body.

Perforations not to scale.

89450 Fully Adjustable Cable Installation Instructions

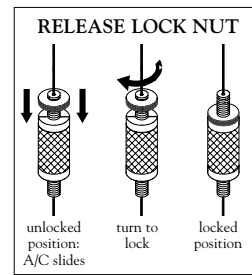

ADJUSTABLE CABLE GRIPPER ASSEMBLY

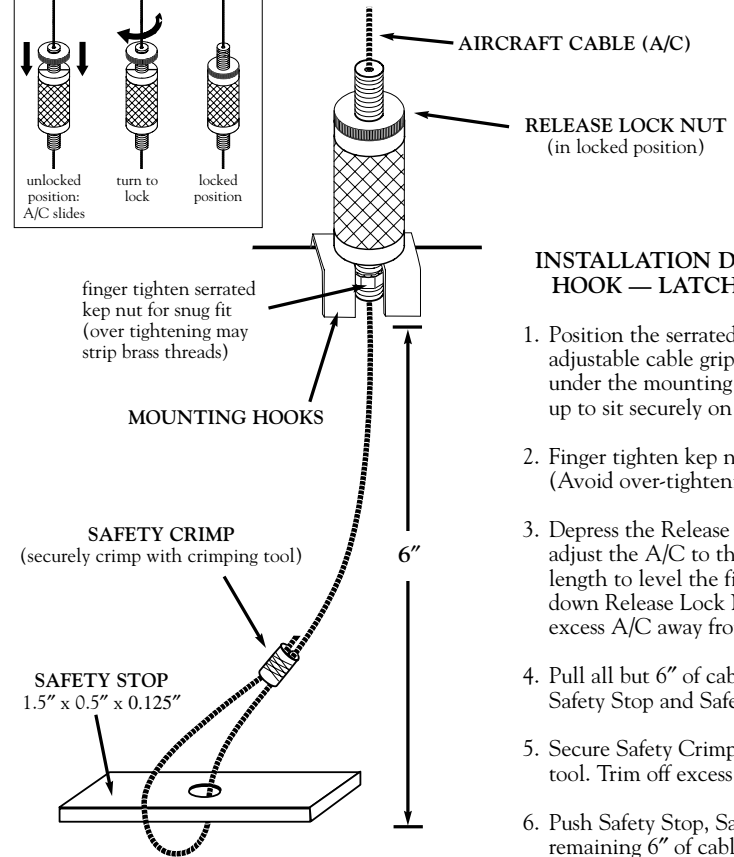

INSTALLATION DIRECTIONS HOOK — LATCH — LEVEL

1. Position the serrated keping nut of the adjustable cable gripper assembly under the mounting hooks, rotate up to sit securely on top of hook.
2. Finger tighten keping nut until secure. (Avoid over-tightening.)
3. Depress the Release Lock Nut to adjust the A/C to the correct length to level the fixture. Screw down Release Lock Nut. Pull down excess A/C away from fixture.
4. Pull all but 6" of cable up through Safety Stop and Safety Crimp.
5. Secure Safety Crimp with crimping tool. Trim off excess cable.
6. Push Safety Stop, Safety Crimp and remaining 6" of cable down into fixture body.

89450 Fully Adjustable Cable Assembly