

FINELITE

Series 16 Instructions Fully Adjustable Cable*

ADJUST & LEVEL

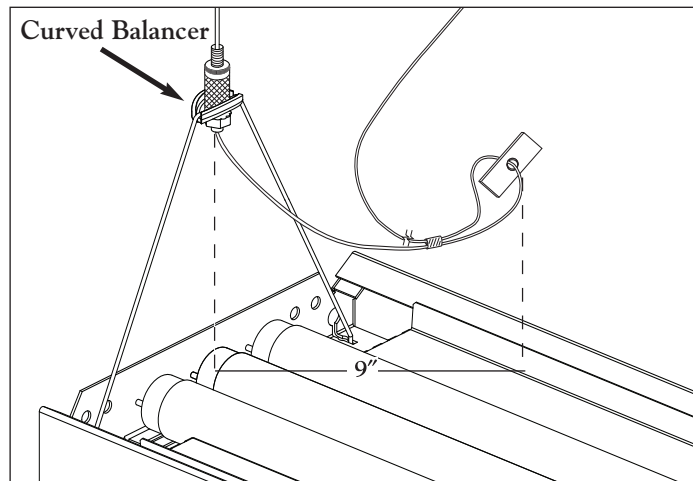

1. Lower bottom keps nut to desired location and securely hook the balancer cable attached to the luminaire. Move slider for side to side leveling. Lock by turning cable gripper securely until serrated keps nut fits tightly against slider.

SECURE & TRIM

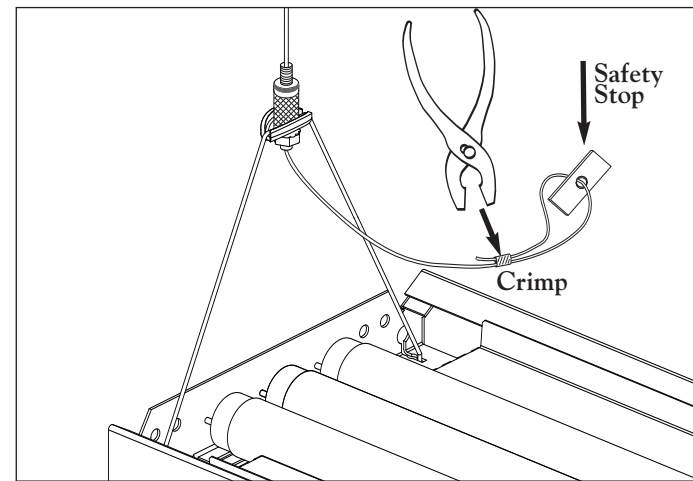

2. Unscrew release lock nut and depress to adjust cable height, turn to lock. Slide Safety Stop and Safety Crimp up to cable to within 9" of cable gripper. Trim excess cable. Lower Safety Stop.

INSERT TO COMPLETE (joint detail)

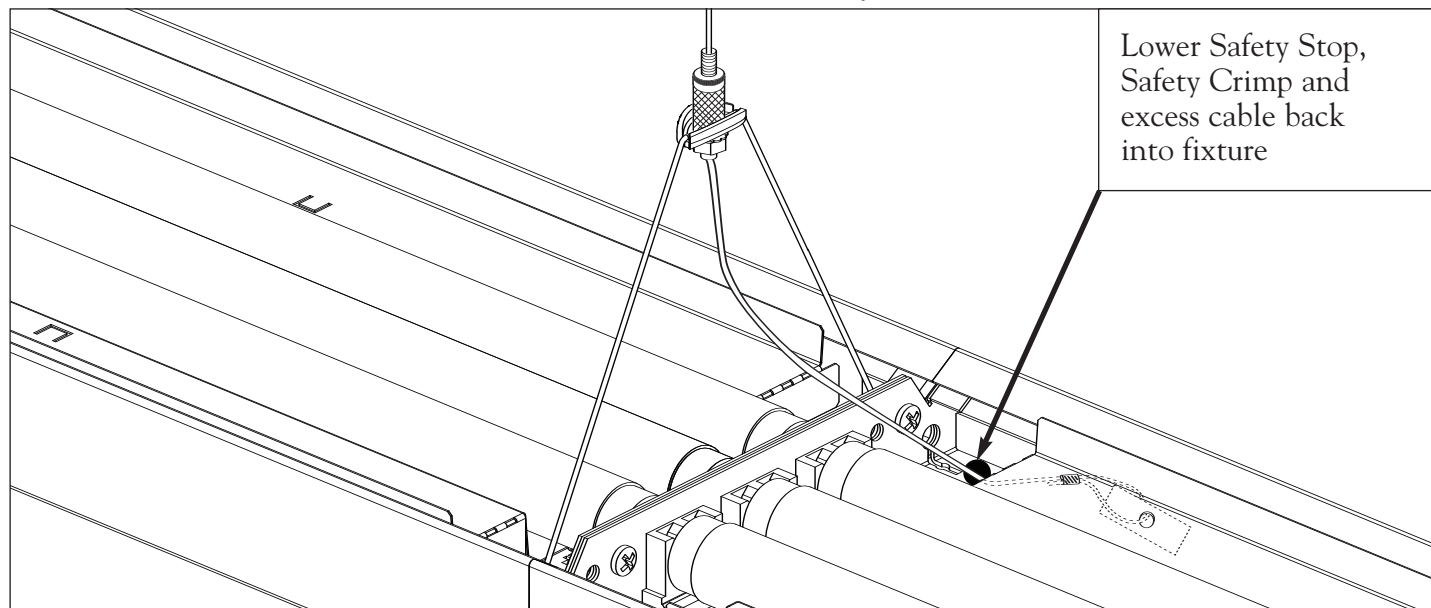

Lower Safety Stop, Safety Crimp and excess cable back into fixture

FINAL CHECK: In completed installation the release lock nut is screwed down, serrated keps nut is tight against slider and crimp has been secured. Safety Stop, Safety Crimp and 9" of aircraft cable are securely inside fixture body.

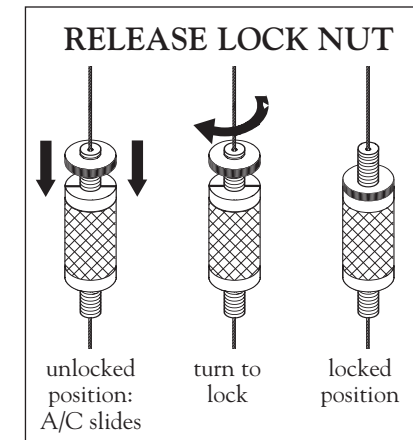

Serrated keps nut sits tightly against slider (secures cable side to side position)

CURVED BALANCER

SAFETY CRIMP (securely crimp with crimping tool)

SAFETY STOP



ADJUSTABLE CABLE GRIPPER ASSEMBLY

AIRCRAFT CABLE (A/C)

RELEASE LOCK NUT (secures cable height - shown in locked position)

INSTALLATION DIRECTIONS BALANCER ASSEMBLY SERIES 16

1. Lower the bottom keps nut to desired location and securely hook the balancer cable attached to the luminaire.
2. Level the luminaire and secure with the top keps nut on the fully adjustable or semi-adjustable cable. Cable must be secured under keps nut.
3. Shown below are the correct ways to secure the balancer assembly under the Semi-Adjustable and Fully-Adjustable cables.

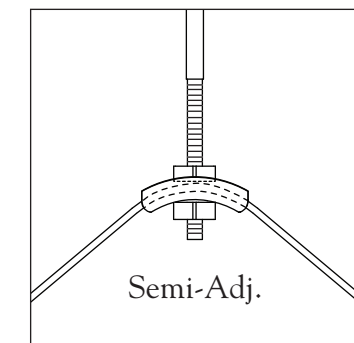

Semi-Adj.

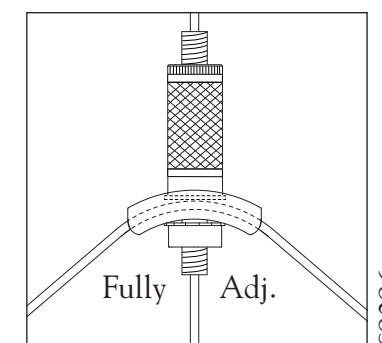

Fully Adj.

89450 Fully Adjustable Cable Installation Instructions

89450 Fully Adjustable Cable Assembly

DO NOT attempt to join fixtures together on the floor. Damage may result when lifted. Follow these instructions.

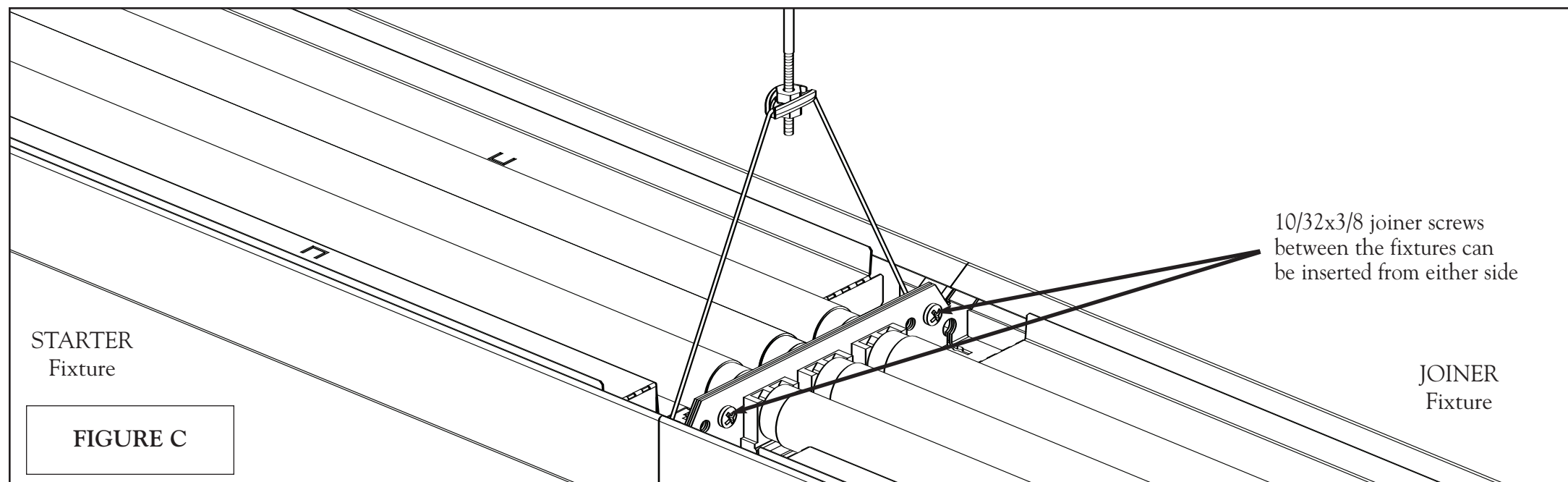
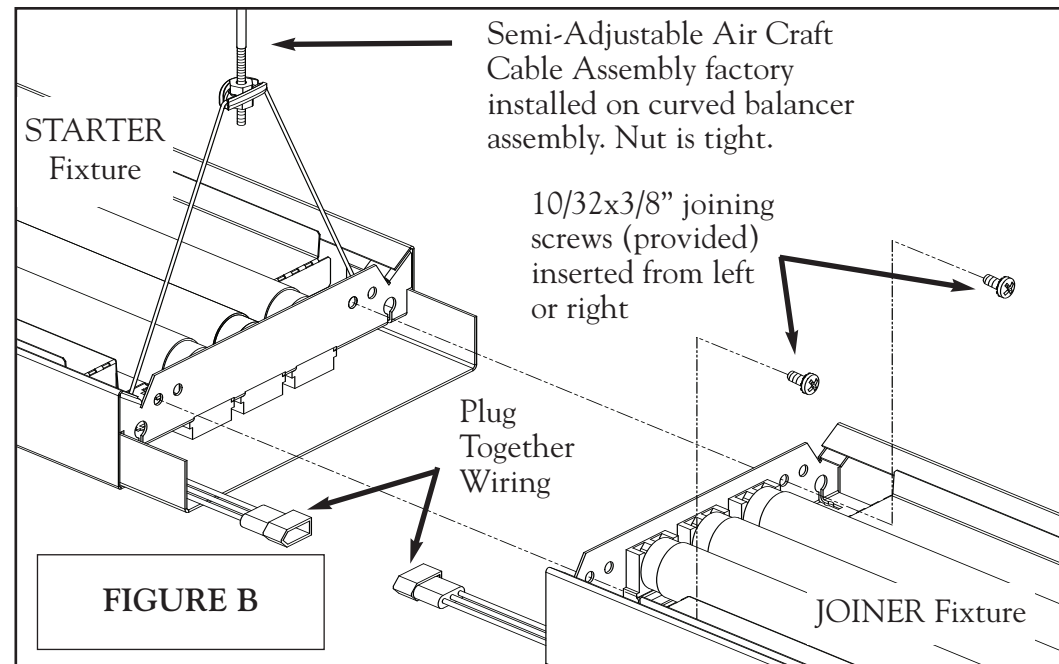
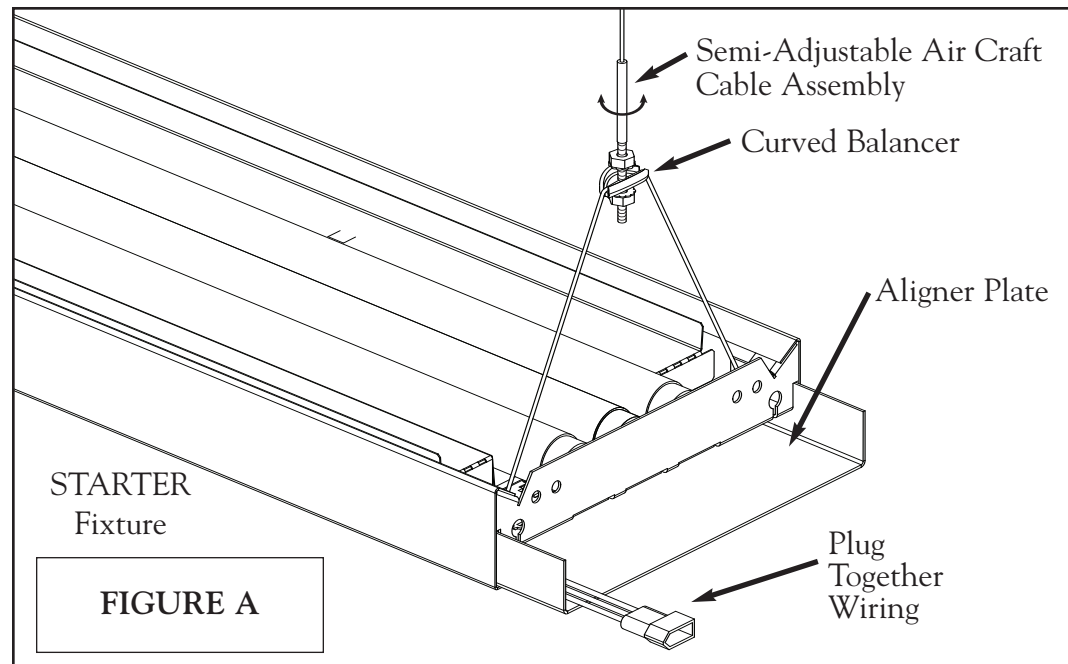

INSTRUCTIONS

STEP 1. Hang STARTER fixture at both ends by inserting threaded end of Semi-Adjustable hardware into curved balancer assembly, turn to adjust height. Adjust slider to ensure side to side leveling, screw nut down to lock. **FIGURE A.**

STEP 2. Hang far end of JOINER fixture while supporting both ends. Connect plug together wiring between STARTER fixture and JOINER fixture. Slide JOINER fixture onto aligner plate. Push fixtures together. Secure fixtures together with **two** 10/32x3/8" screws (provided). (Screws may be inserted from left or right). **FIGURE B.**

FINAL CHECK—FIGURE C.

- Air Craft Cable Assembly sits securely on curved balancer assembly, nut is tight.
- Plug together wiring is connected.
- **Two** 10/32x3/8" joiner screws have been installed between fixtures.

Repeat for remaining JOINER and ENDER fixtures to complete row.

* Pictured with Semi-Adjustable Air Craft Cable Assembly. See additional instructions for Fully Adjustable Air Craft Cable hardware.