

# FINELITE

**DO NOT** attempt to join fixtures together on the floor. Damage may result when lifted. Follow these instructions.

## SURFACE MOUNT & MOUNTING BRACKET

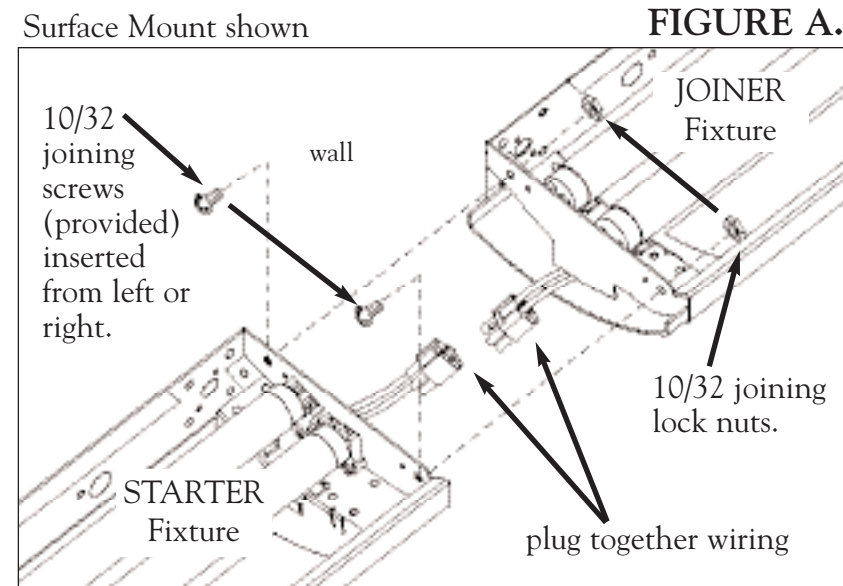

**STEP 1.** Follow Finelite S12WM Surface Mount or Mounting Bracket instructions to install STARTER fixture.

**STEP 2. Surface Mount** - Hold JOINER fixture up to wall. Connect plug-together wiring. **FIGURE A.**

**Mounting Bracket** - Hold JOINER fixture up to wall. Raise JOINER slightly above mounting bracket and holding fixture parallel to wall, slide fixture straight down to engage top and bottom edges in mounting bracket. Connect plug-together wiring.

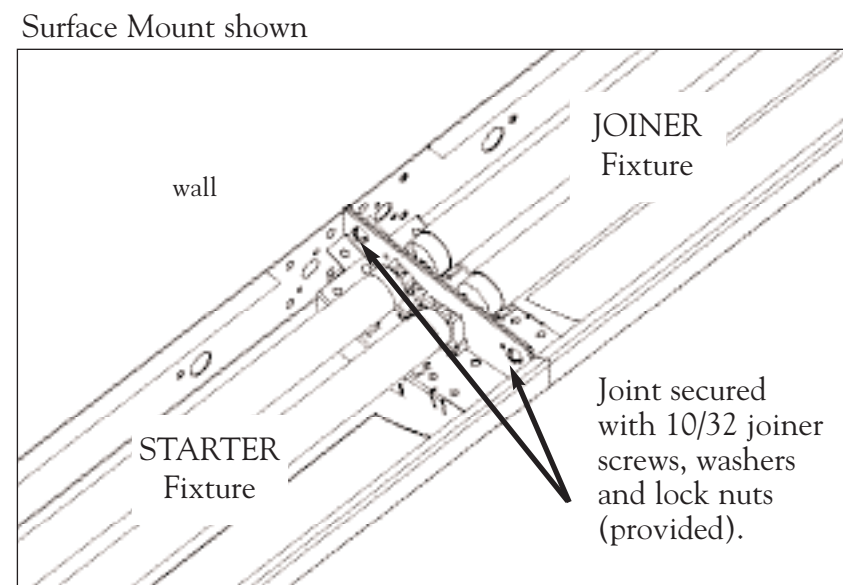

**STEP 3.** Slide JOINER into STARTER fixture.

**STEP 4.** Secure fixtures together with two joiner 10/32 screws and lock nuts (provided) to complete connection. **FIGURE B.**

**Mounting Bracket** - Insert one 8/32 rack adjustment screw (provided) on each side of joint and thread into Mounting Bracket. Tighten/loosen to level fixture. Refer to S12WM Mounting Bracket instructions for more information.

**STEP 5. Surface Mount** - Secure JOINER fixture to wall studs as described in installation instructions.

**Repeat for remaining JOINER and ENDER fixtures to complete row.**

### FINAL CHECK - FIGURE B.

- Plug together wiring is connected.
- Two 10/32 screws have been installed between fixtures and rack adjustment screws installed - (Mounting Bracket only).

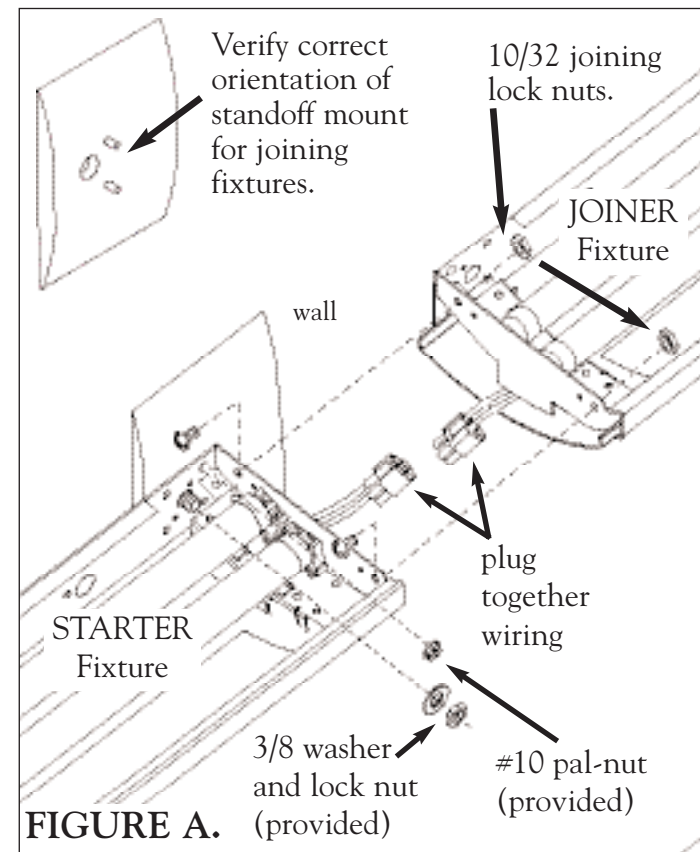

## STANDOFF MOUNT

**STEP 1.** Follow Finelite S12WM Standoff Mount instructions to install STARTER fixture. **Verify correct orientation of standoff mount for joining fixtures.**

**STEP 2.** Hold JOINER fixture up to wall. Connect plug-together wiring. Slide JOINER into STARTER fixture. Install (1) 3/8" washer, (1) 3/8" lock nut and #10 pal-nut (provided) to standoff mount. **FIGURE A.**

**STEP 3.** Secure fixtures together with two joiner 10/32 screws and lock nuts (provided) to complete connection. The fixture is supported ever 48", regardless of fixture length. The last mounting is 1.125" in from fixture end of fixture body. **FIGURE B.**

**NOTE** - Orientation of standoff mount on last support location. Standoff mount might need to be rotated 180° depending on if you are using a flat or curved endcap. Refer to S12WM Standoff instructions for more information.

### FINAL CHECK - FIGURE B.

- Verify correct orientation of standoff mount.
- Plug together wiring is connected.
- 3/8" washer, lock nut and #10 pal-nut installed.
- Two 10/32 screws have been installed between fixtures.

**Repeat for remaining JOINER and ENDER fixtures to complete row.**

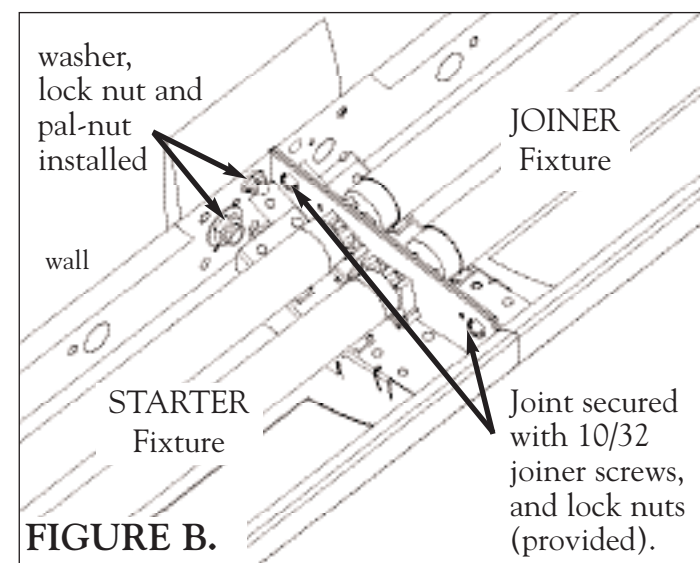

### Series 12 Wall Mount Joining Instructions