

FINELITE

Series 12WM Instructions - Surface Mount (SUR)

INSTRUCTIONS

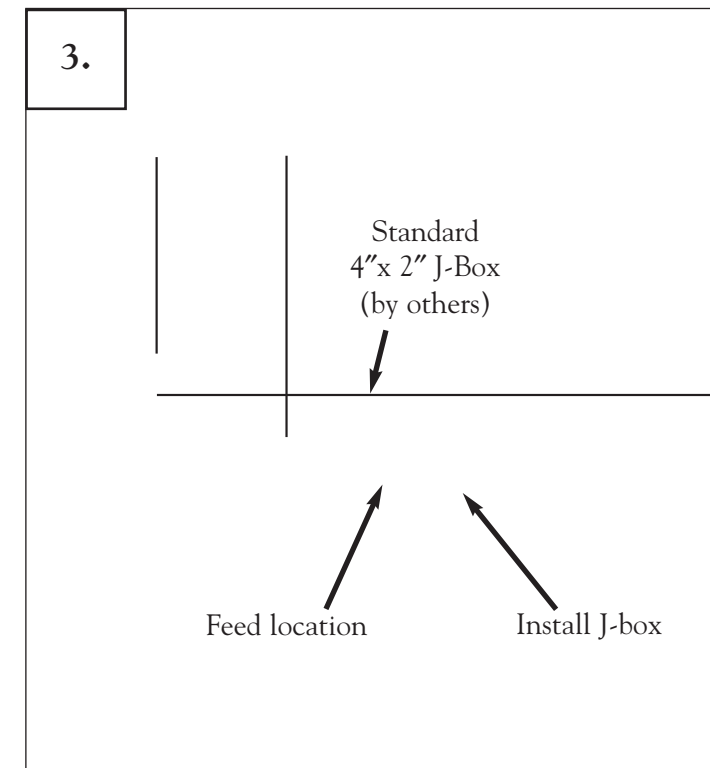
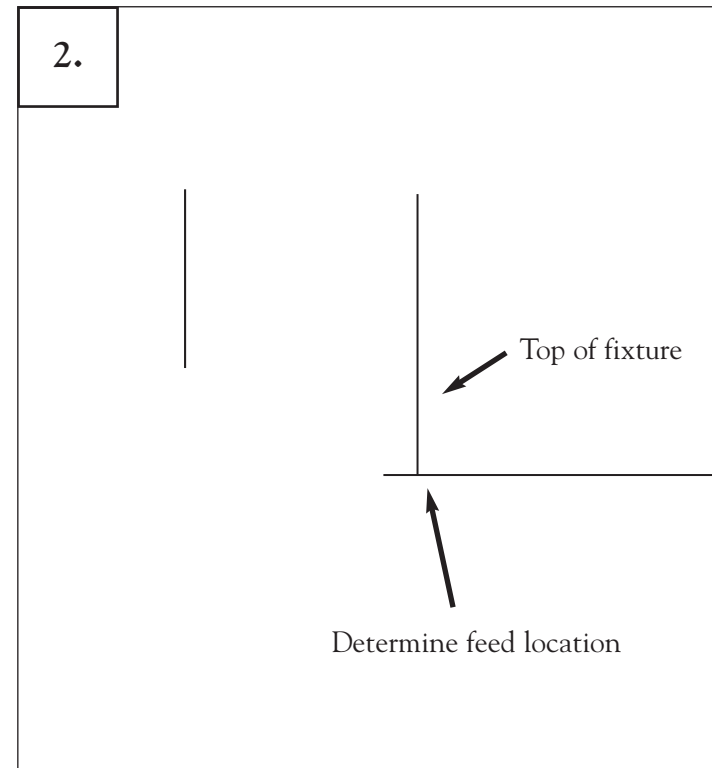
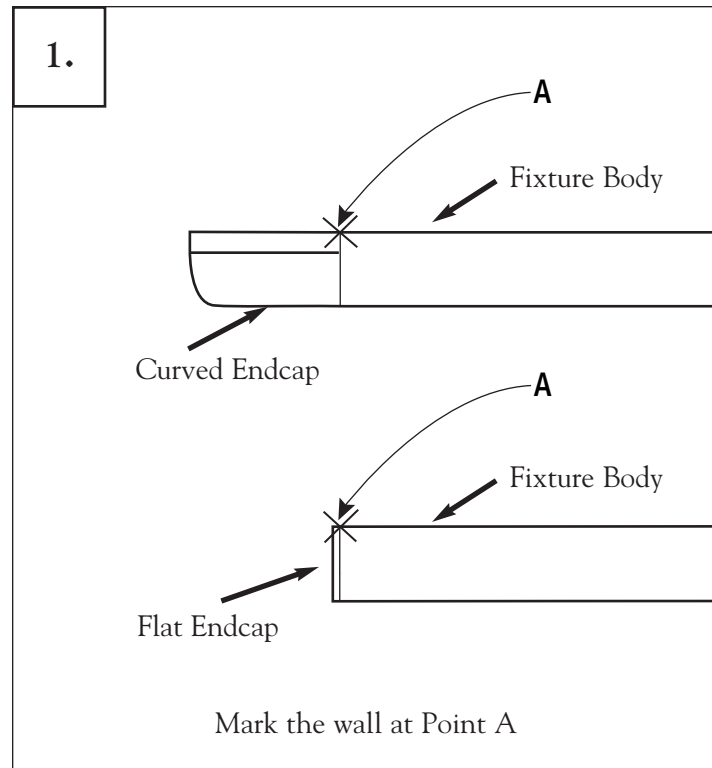

1. Position fixture on wall in desired location. Mark on wall the point where the endcap and the fixture body meet. This is Point A. Remove fixture.
2. Determine feed location by measuring a horizontal line 4.5" from Point A toward center of fixture, then 1.25" downward. Mark this spot for feed.
3. Install 4"x2" J-Box centering box over feed location and align top of box with Point A. Leave 8-10" of power wire exposed.

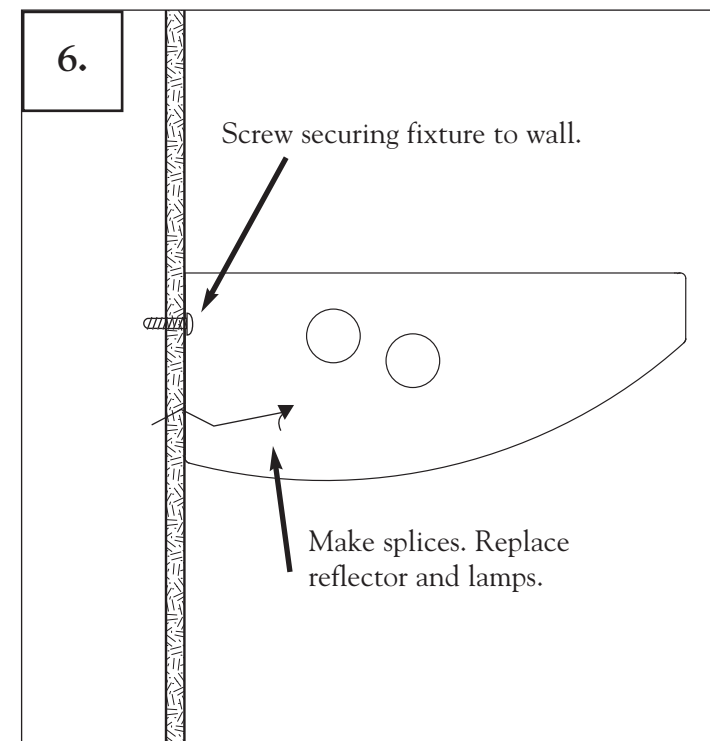
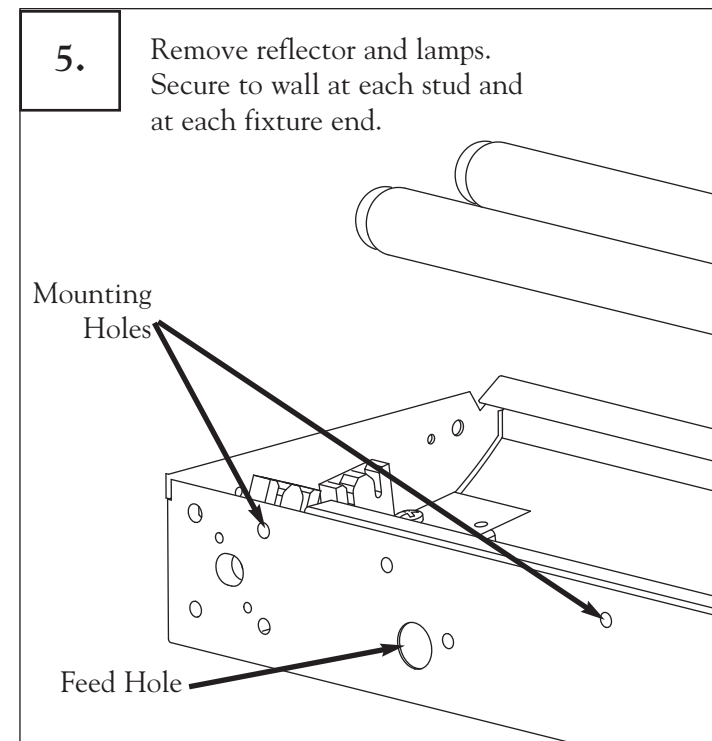
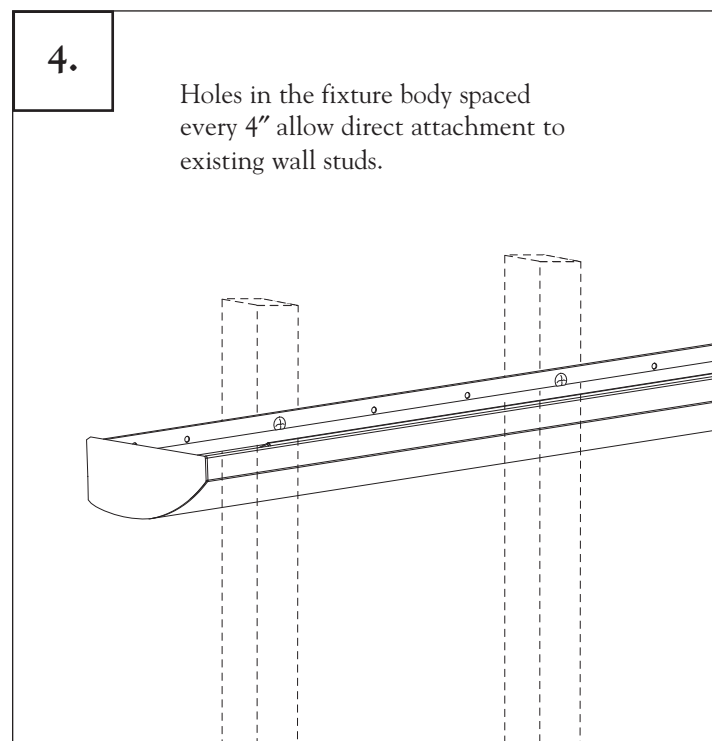

4. Attach fixture to stud and level. At each support location that is not secured into a stud (usually fixture ends) drill hole 1.25" down from Point A. Backing as required.
5. Remove reflector and lamps. Position fixture on wall level and secure to wall at each end and at each stud.
6. Make splices, reinstall reflector and lamps.

NOTE: All power connections to be installed to local/national codes by a Certified Electrician.

Series 12 Wall Mount (Surface) Installation Instructions