

# FINELITE

## Series 12-ID Joining Instructions (Semi-Adjustable Cable)\*

DO NOT attempt to join fixtures together on the floor. Damage may result when lifted. Follow these instructions.

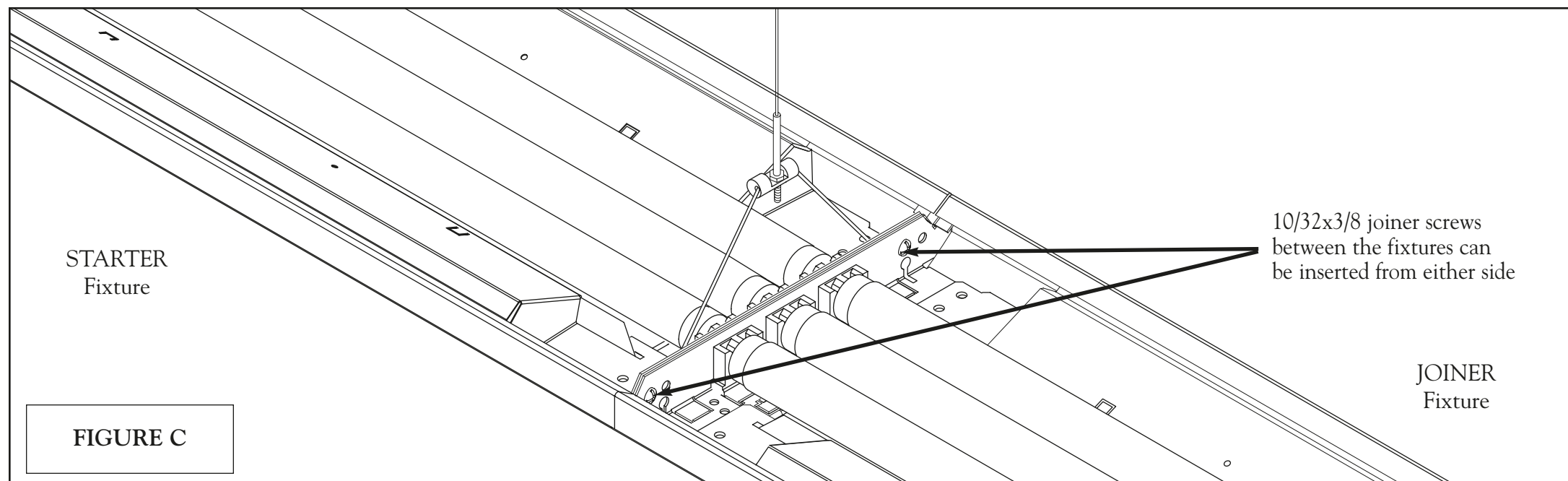
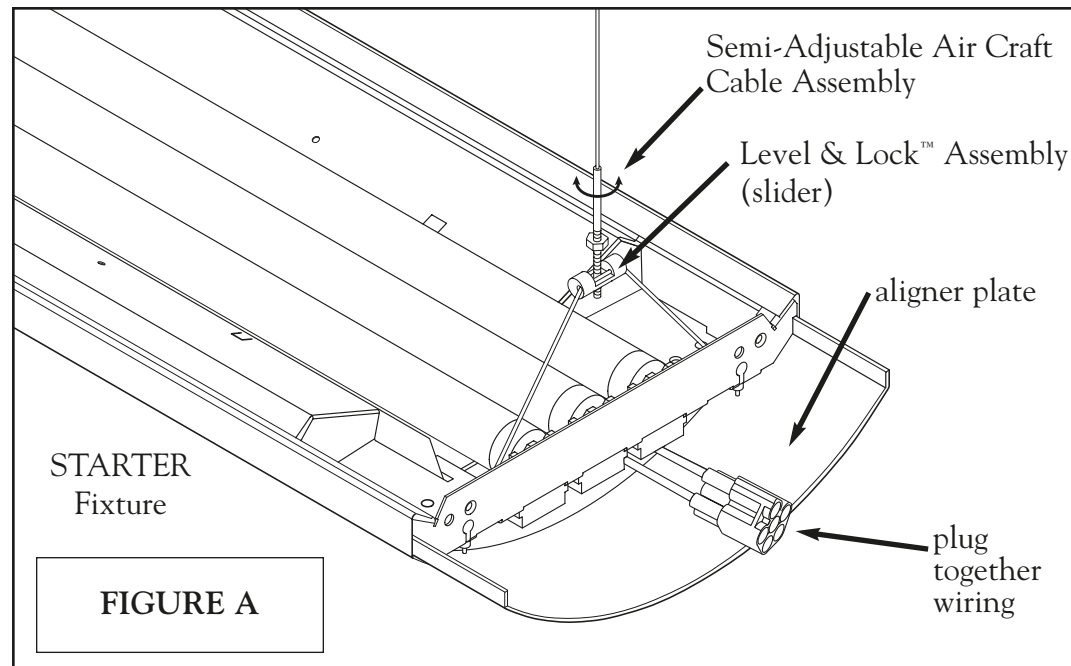

### INSTRUCTIONS

**STEP 1.** Hang STARTER fixture at both ends by inserting threaded end of Semi-Adjustable hardware into Level & Lock™ assembly, turn to adjust height. Adjust slider to ensure side to side leveling, screw nut down to lock. **FIGURE A.**

**STEP 2.** Hang far end of JOINER fixture while supporting both ends. Connect plug together wiring between STARTER fixture and JOINER fixture. Slide JOINER fixture onto aligner plate. Push fixtures together. Secure fixtures together with **two** 10/32x3/8 screws (provided). (Screws may be inserted from left or right). **FIGURE B.**

### FINAL CHECK—FIGURE C.

- Air Craft Cable Assembly sits securely on Level & Lock™ assembly, nut is tight.
- Plug together wiring is connected.
- **Two** 10/32x3/8 joiner screws have been installed between fixtures.

Repeat for remaining JOINER and ENDER fixtures to complete row.

\* Pictured with Semi-Adjustable Air Craft Cable Assembly. See additional instructions for Fully Adjustable Air Craft Cable hardware.