

FINELITE

Series 12-ID Instructions Fully Adjustable Cable*

ADJUST & LEVEL

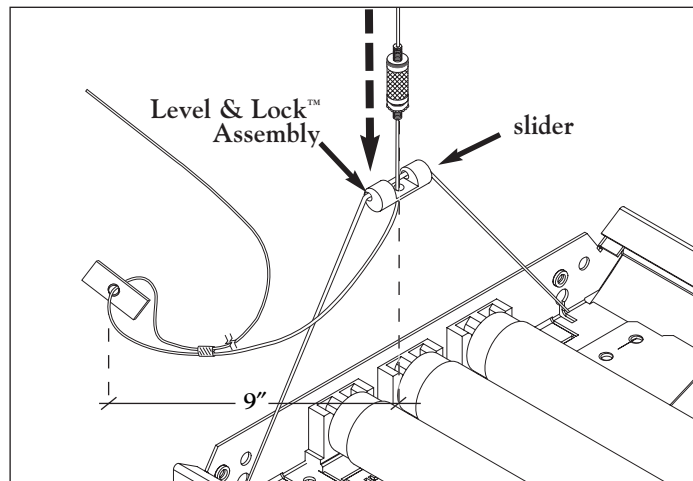

1. Position the adjustable cable gripper over the Level & Lock™ Assembly, turn to engage threads. Move slider for side to side leveling. Lock by turning cable gripper securely until serrated keps nut fits tightly against slider.

SECURE & TRIM

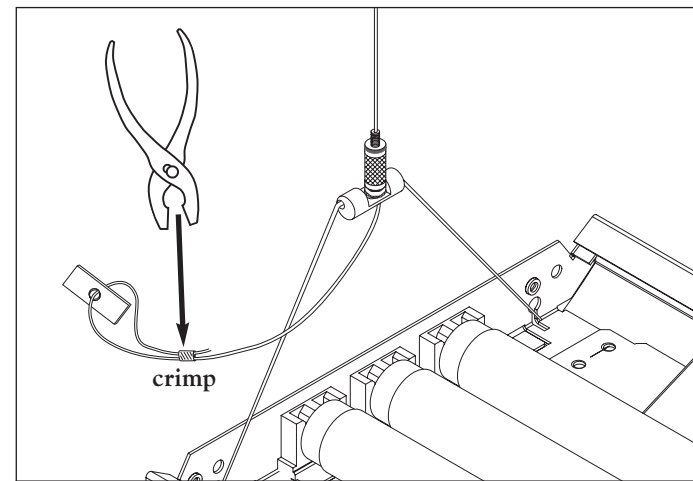

2. Unscrew release lock nut and depress to adjust cable height, turn to lock. Slide Safety Stop and Safety Crimp up to cable to within 9" of cable gripper. Secure Safety Crimp with crimping tool. Trim excess cable. Lower Safety Stop.

INSERT TO COMPLETE (joint detail)

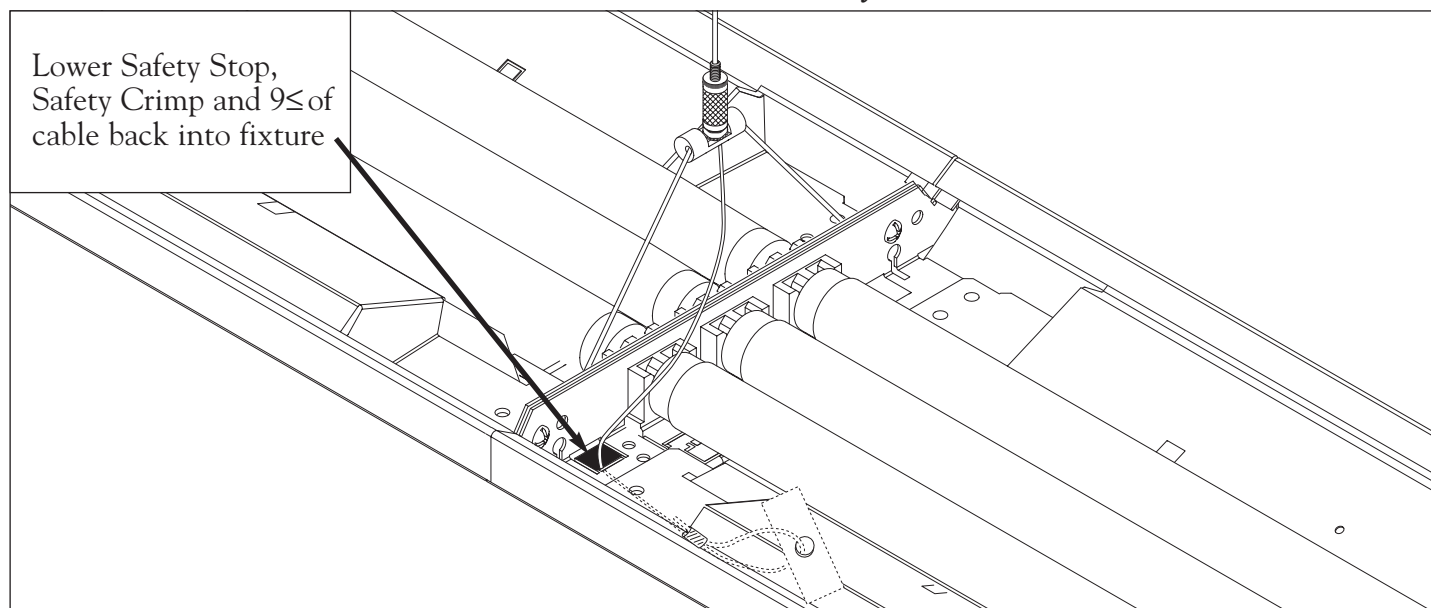

FINAL CHECK: In completed installation the Release Lock Nut is screwed down, serrated keps nut is tight against slider and crimp has been secured. Safety Stop, Safety Crimp and 9" of aircraft cable are securely inside fixture body.

89450 Fully Adjustable Cable Installation Instructions

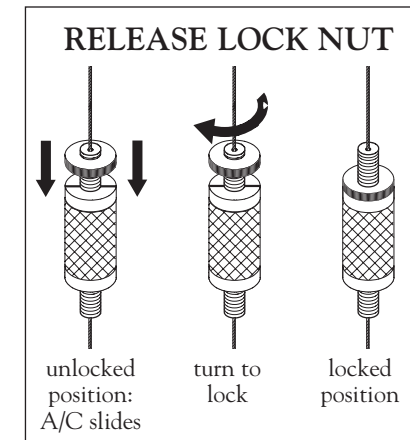

Serrated keps nut sits tightly against slider (secures cable side to side position)

LEVEL AND LOCK™ SLIDER

SAFETY CRIMP (securely crimp with crimping tool)

SAFETY STOP
1.5" x 0.5" x 0.125"

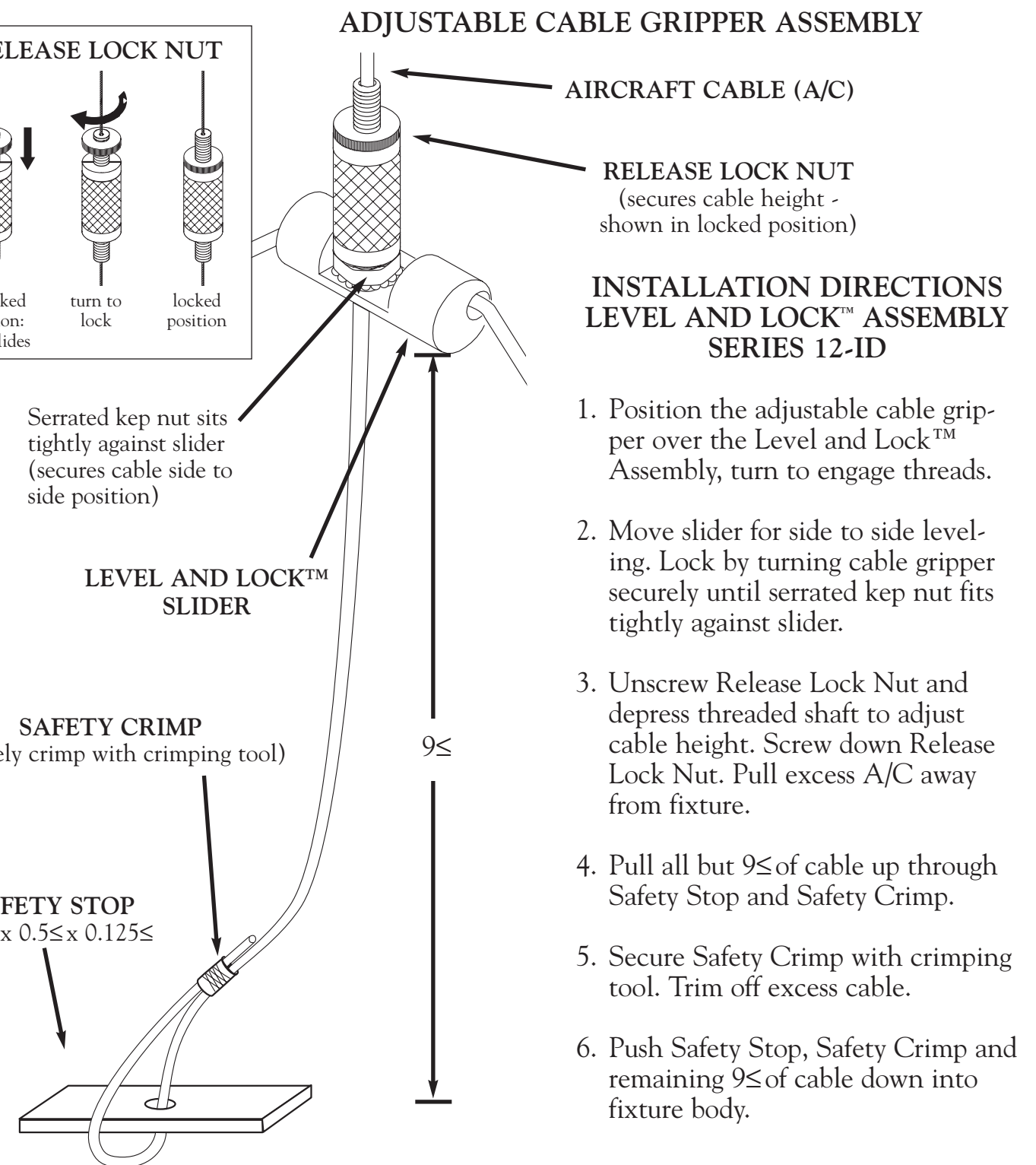

ADJUSTABLE CABLE GRIPPER ASSEMBLY

AIRCRAFT CABLE (A/C)

RELEASE LOCK NUT
(secures cable height - shown in locked position)

INSTALLATION DIRECTIONS
LEVEL AND LOCK™ ASSEMBLY
SERIES 12-ID

1. Position the adjustable cable gripper over the Level and Lock™ Assembly, turn to engage threads.
2. Move slider for side to side leveling. Lock by turning cable gripper securely until serrated keps nut fits tightly against slider.
3. Unscrew Release Lock Nut and depress threaded shaft to adjust cable height. Screw down Release Lock Nut. Pull excess A/C away from fixture.
4. Pull all but 9" of cable up through Safety Stop and Safety Crimp.
5. Secure Safety Crimp with crimping tool. Trim off excess cable.
6. Push Safety Stop, Safety Crimp and remaining 9" of cable down into fixture body.

89450 Fully Adjustable Cable Assembly