

E3 Driver Replacement Instructions

Overview

NOTES | • All power connections should be installed according to local/national codes by a Certified Electrician.

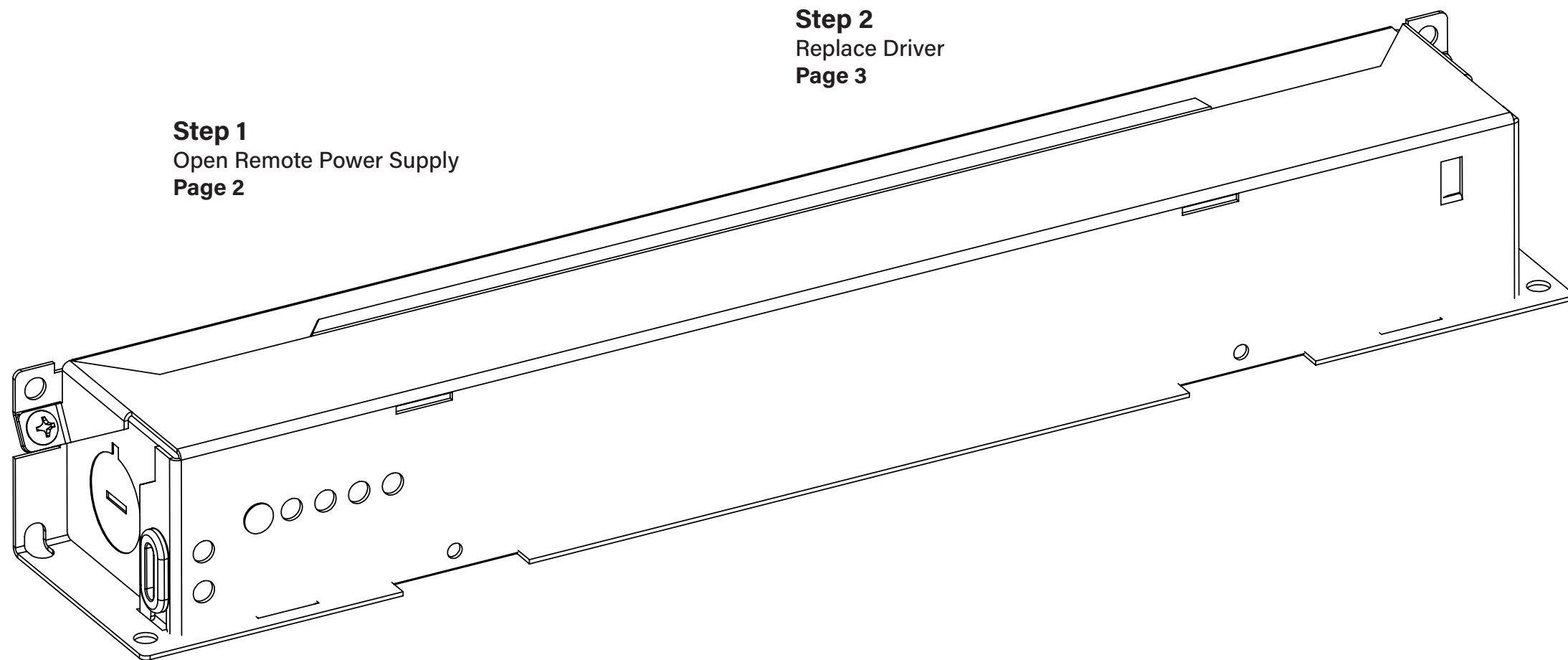

Step 1
Open Remote Power Supply
Page 2

Step 2
Replace Driver
Page 3

E3 Driver Replacement Instructions

Step 1 - Open Remote Power Supply

A. Remove Screws

Note to Turn off Power

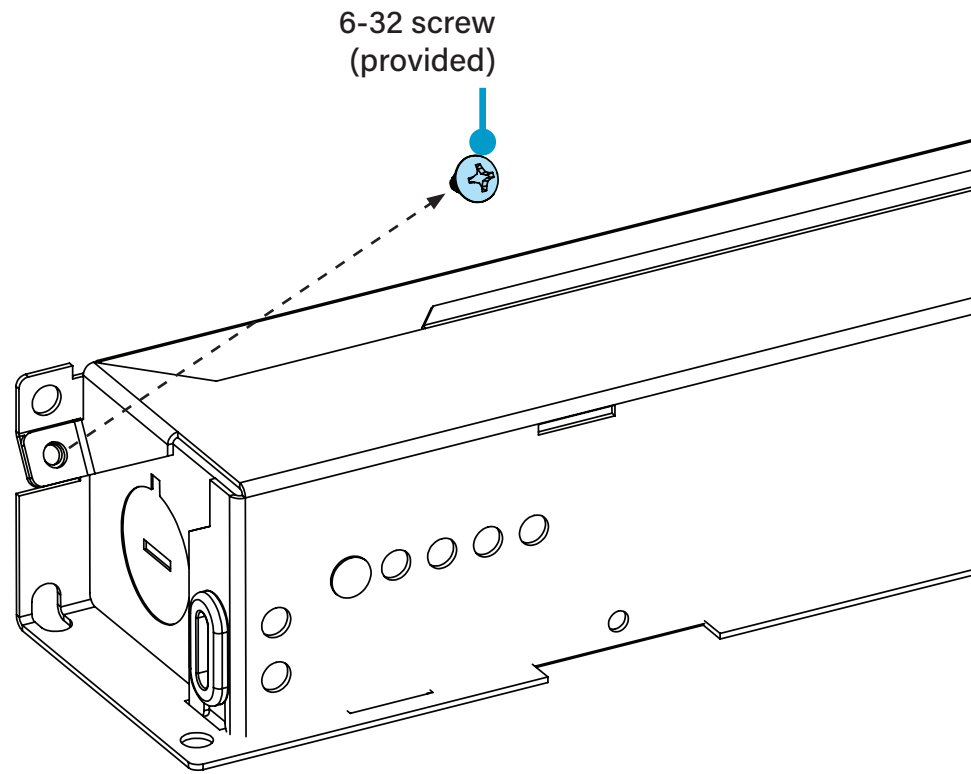

- Unscrew 2x 6-32 screws with #2 Philips to remove the cover with driver attached.

B. Remove Wires

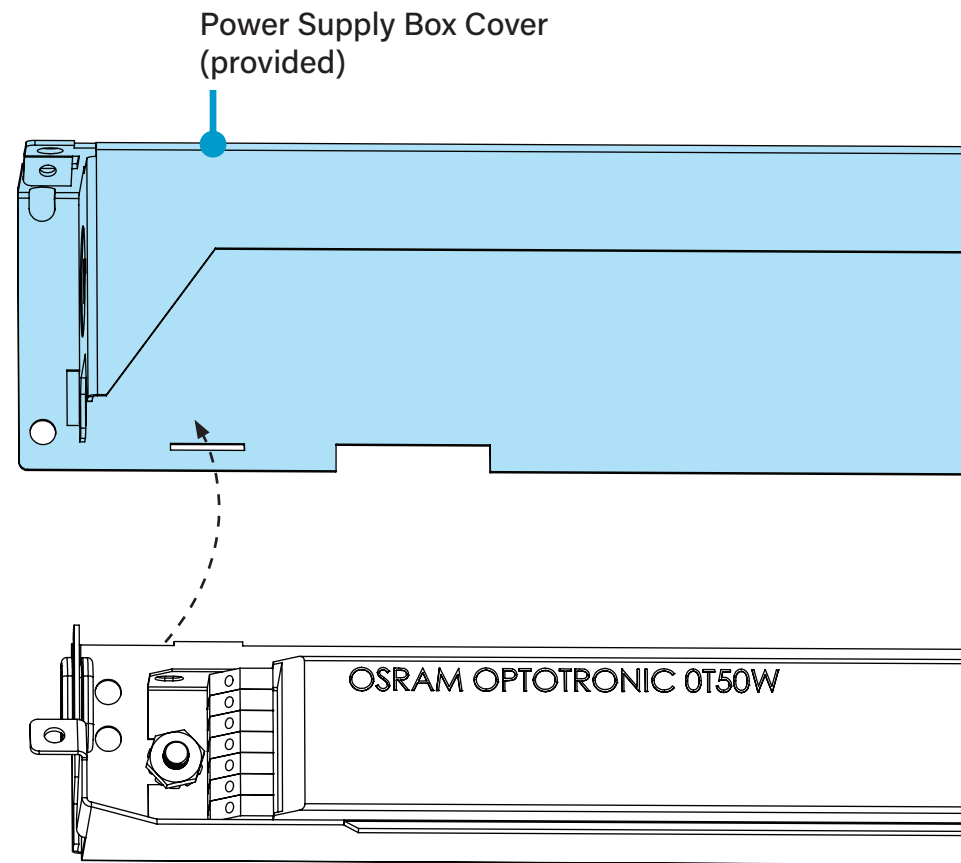

- Remove wires from driver by depressing driver terminal block with tip of small slotted screw driver.

C. Release Driver

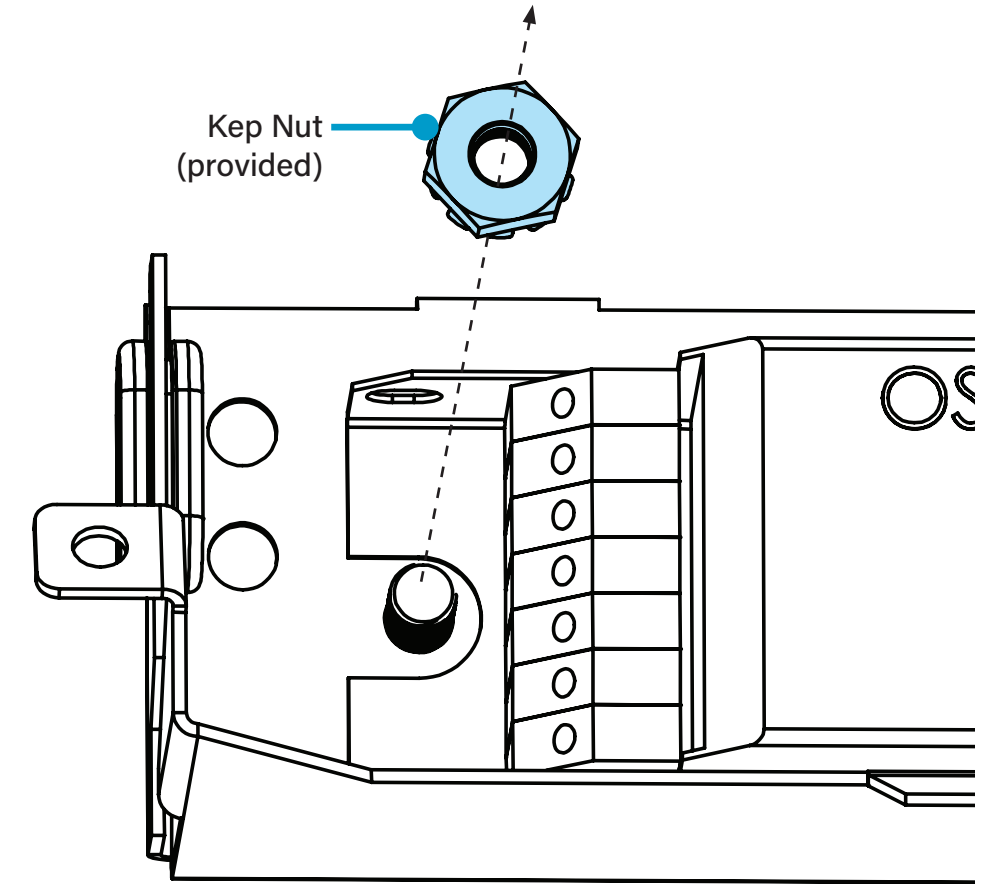

- Remove kep nut to release the driver (use 3/8" nut driver).

E3 Driver Replacement Instructions

Step 2 - Replace Driver

D. Replace Driver

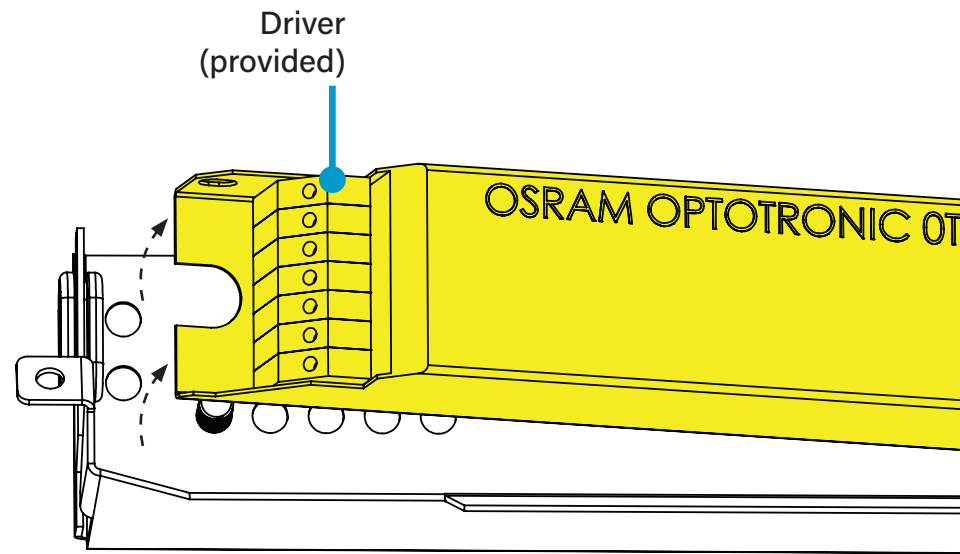

- Tip driver out, and tip in new driver in the same orientation as old driver, hook in one end and then re-secure driver using kep nut.

E. Re-attach Wires

WIRING LEGEND		
AC WIRING		
Black	Hot	Line Voltage
White	Neutral	Line Voltage
Green	Ground	
Pink	Dimming	0-10V DC
Purple	Dimming	0-10V DC
DC WIRING		
Red	Positive (+)	DC Voltage
Black	Negative (-)	DC Voltage

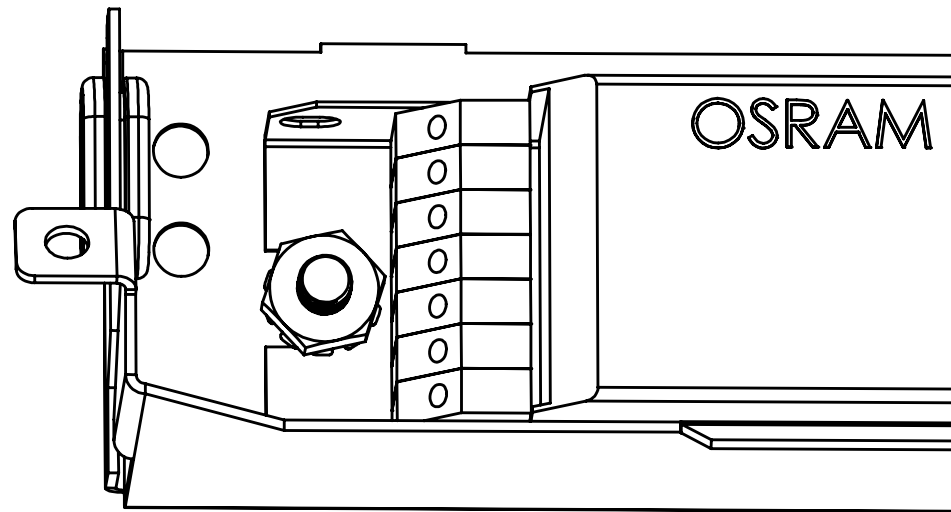

- Re-attach all the wires to their correct location matching the color coded terminal block on the driver.

F. Return Cover

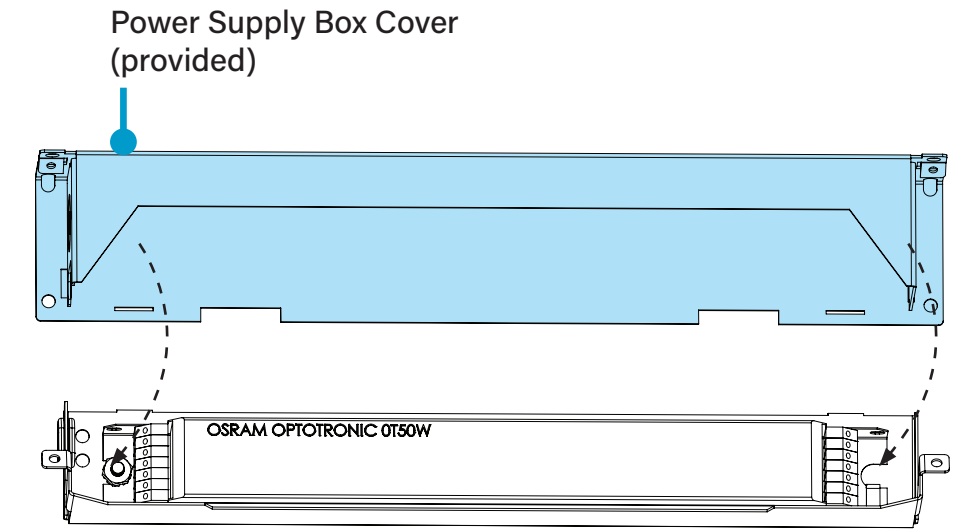

- Rotate driver and cover back into position, carefully tuck in wires to avoid any pinched wires.

E3 Driver Replacement Instructions

Step 2 - Replace Driver

G. Replace Cover

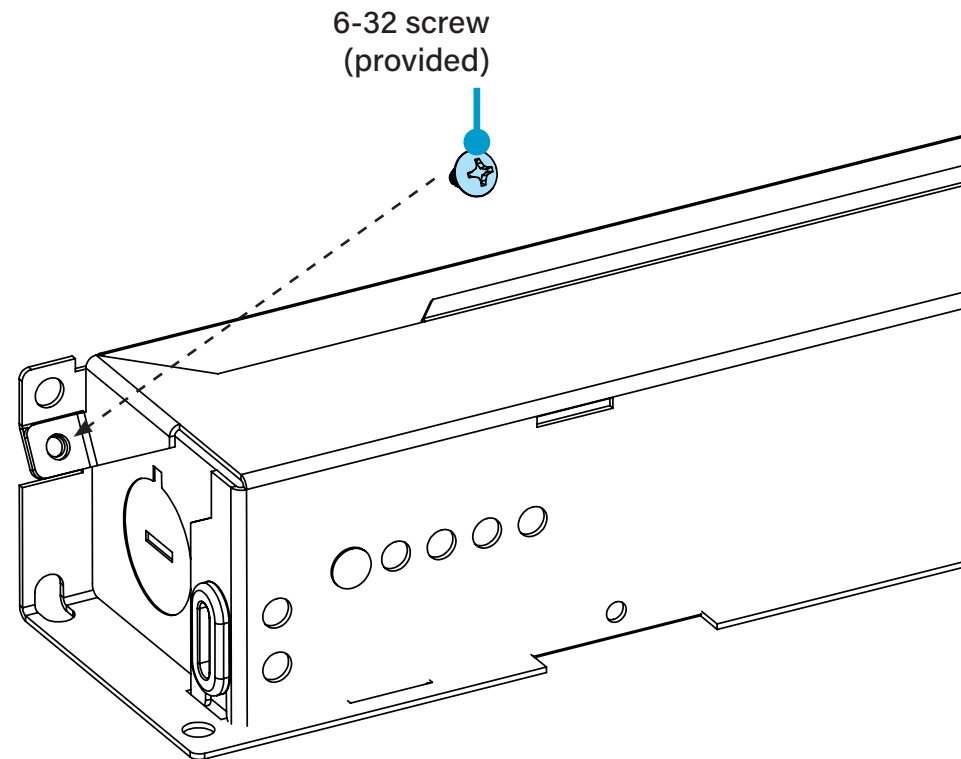

- Secure 2x 6-32 screws to secure cover.

H. Turn Power On

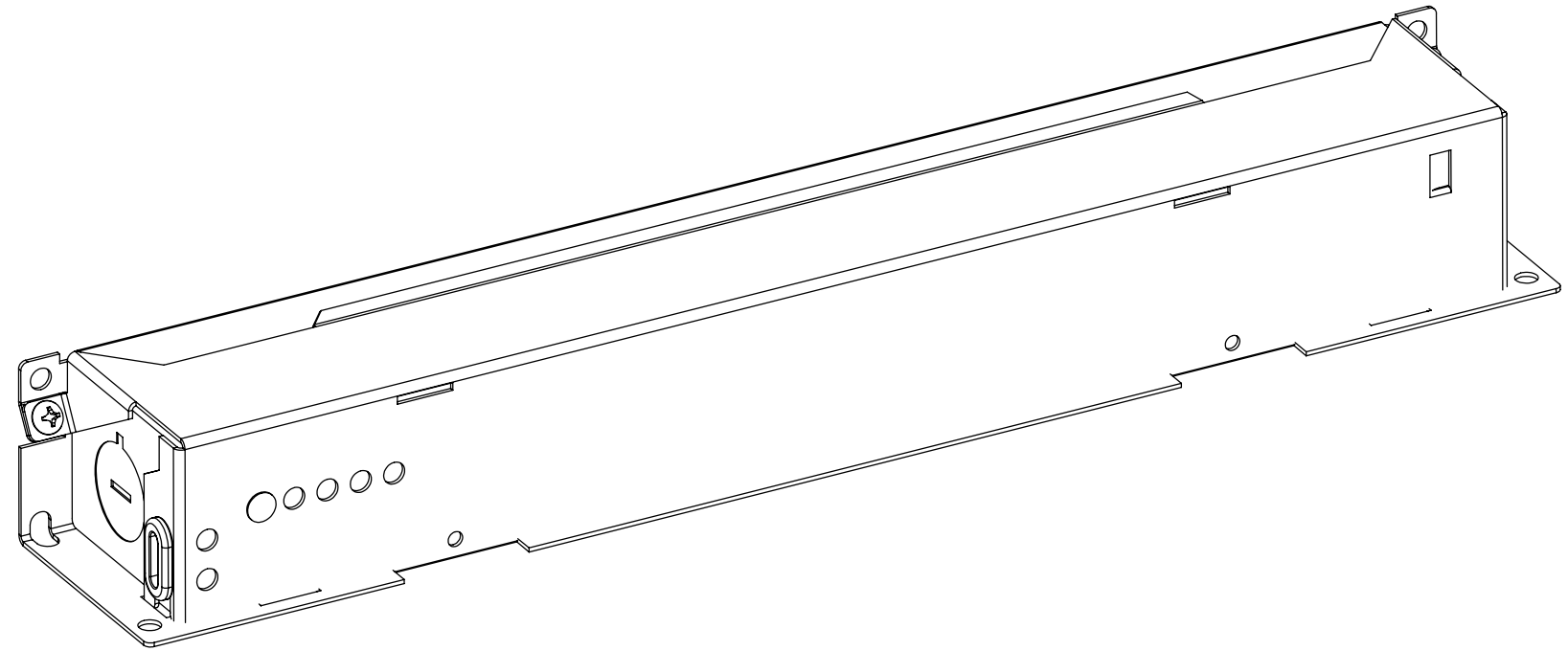

- Turn power back on and test luminaire to ensure it is working.