

Remove #6-32 x 3/16" screw (provided) from the back of the fixture.

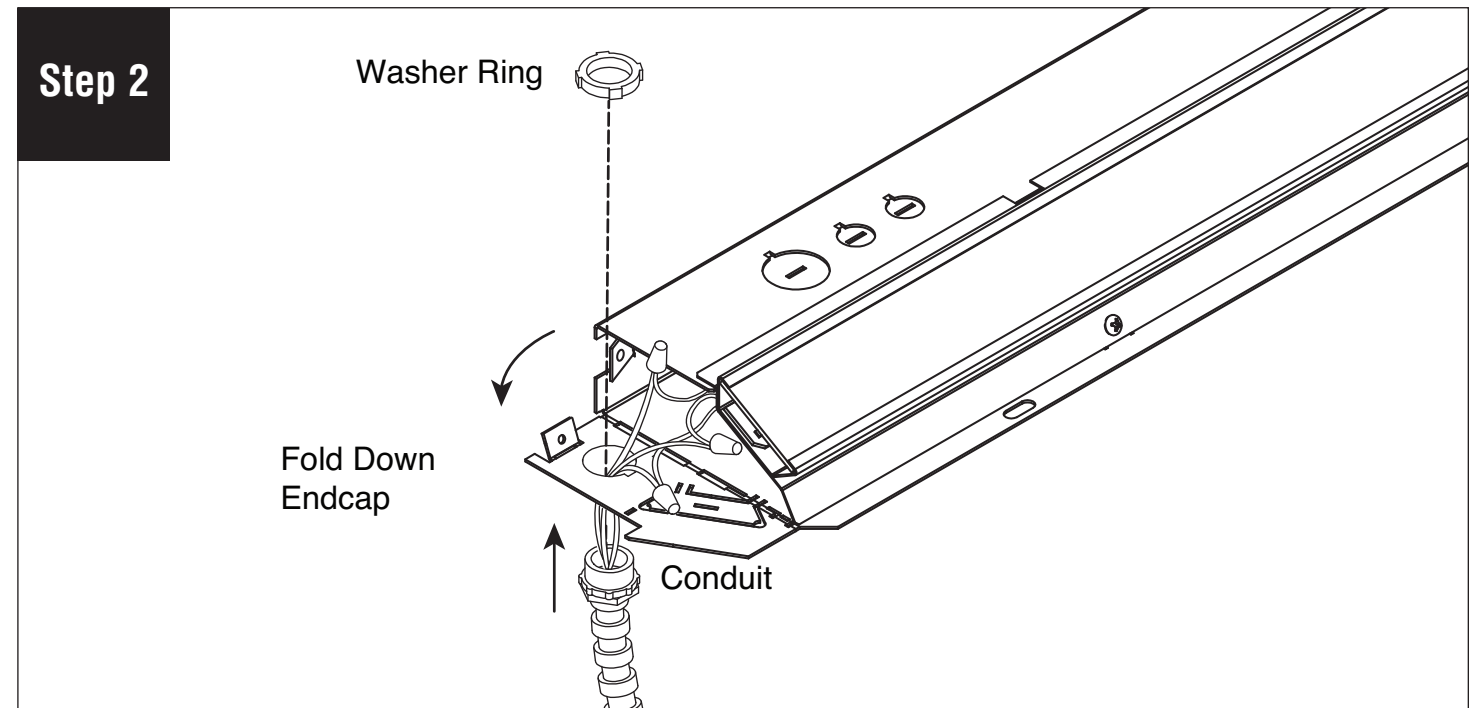

Fold down endcap. Remove knockout, make electrical connection, and install conduit per electrical code.

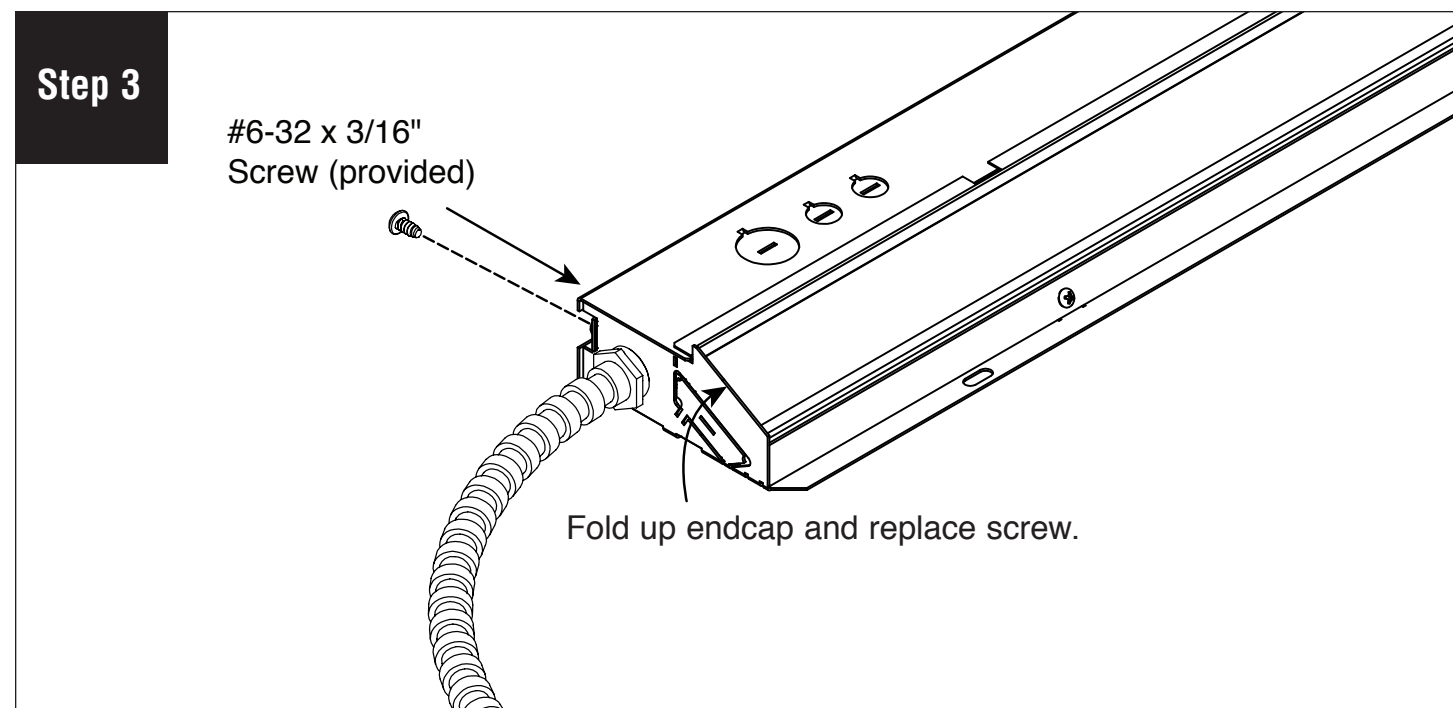

Fold up endcap and replace #6-32 x 3/16" screw (provided).

