

# HP-2 Indirect

## HP-2 Indirect Recycling Luminaire Breakdown

Luminaire breaks down easily for recycling at the end of usable life\*.

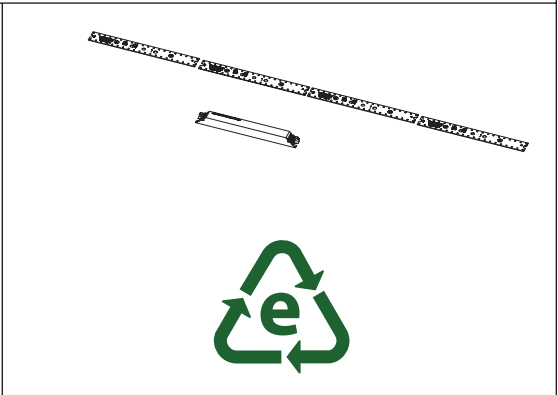
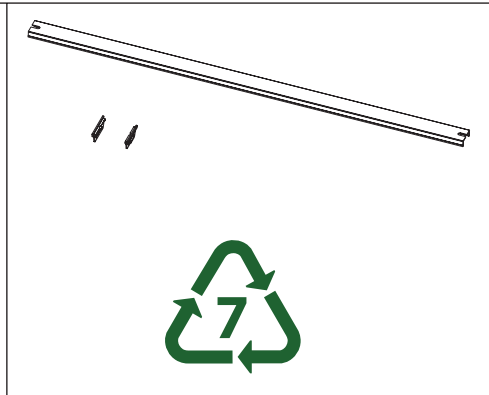
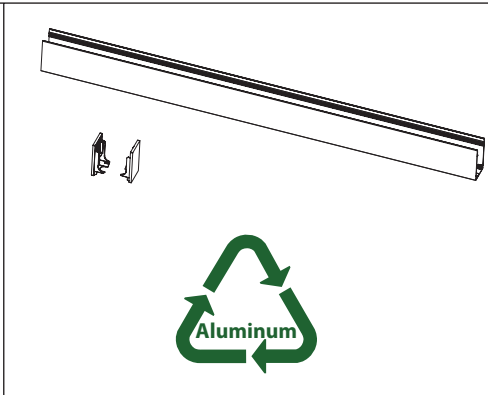
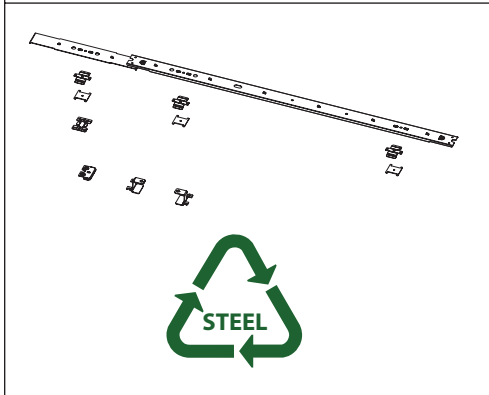
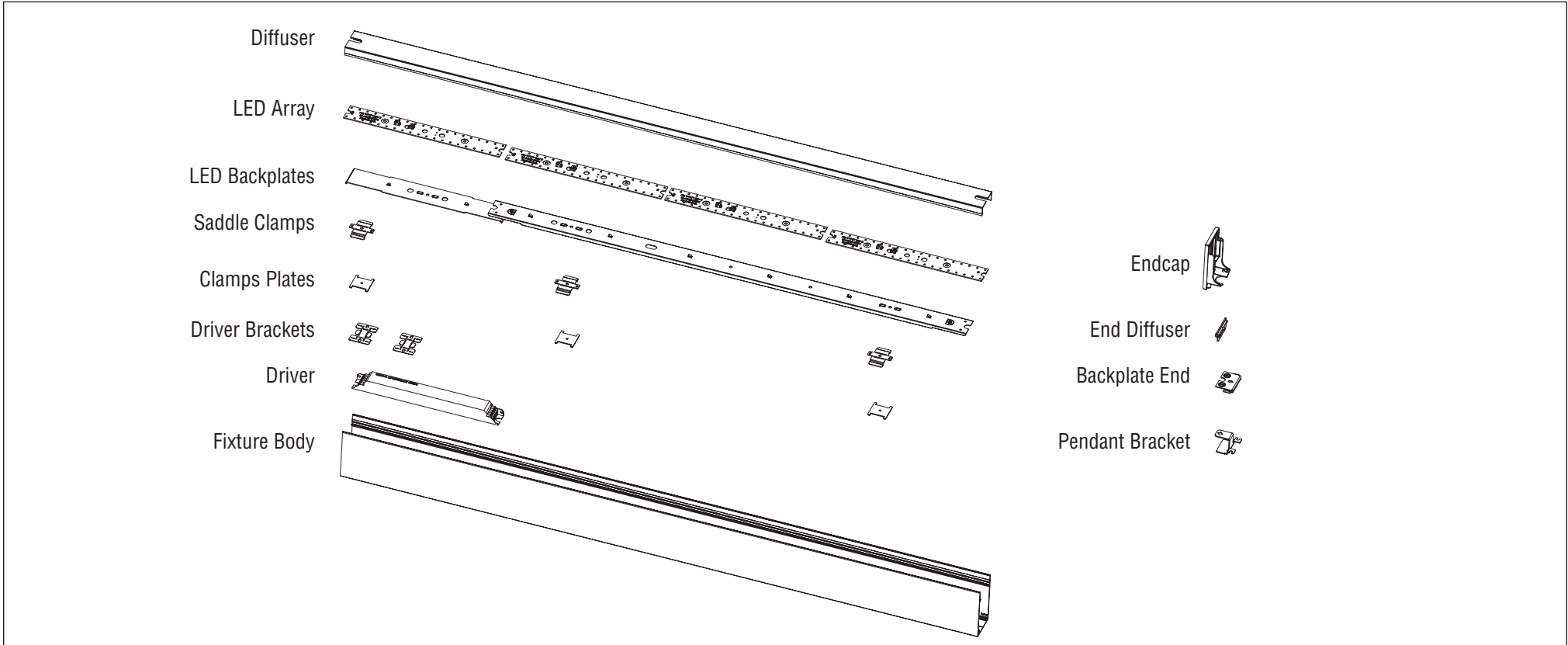

\*Recycling information typical for all luminaire sizes. Contact factory for more information.

Protected by one or more US Patents: 8915613; D702,391; D702,390; D700,732

Due to continuing improvements, Finelite reserves the right to change specifications without notice. Please visit [www.finelite.com](http://www.finelite.com) for most current data.

# HP-2 Indirect

## HP-2 Indirect Recycling Luminaire Breakdown

### 100% Recyclable

HP-2 I components are constructed from aluminum, steel, copper wire, e-waste, and plastic.  
HP-2 I is 100% recyclable at the end of useful life.

