

Series 16 4E LED Engine Replacement Installation Instructions

Step 1

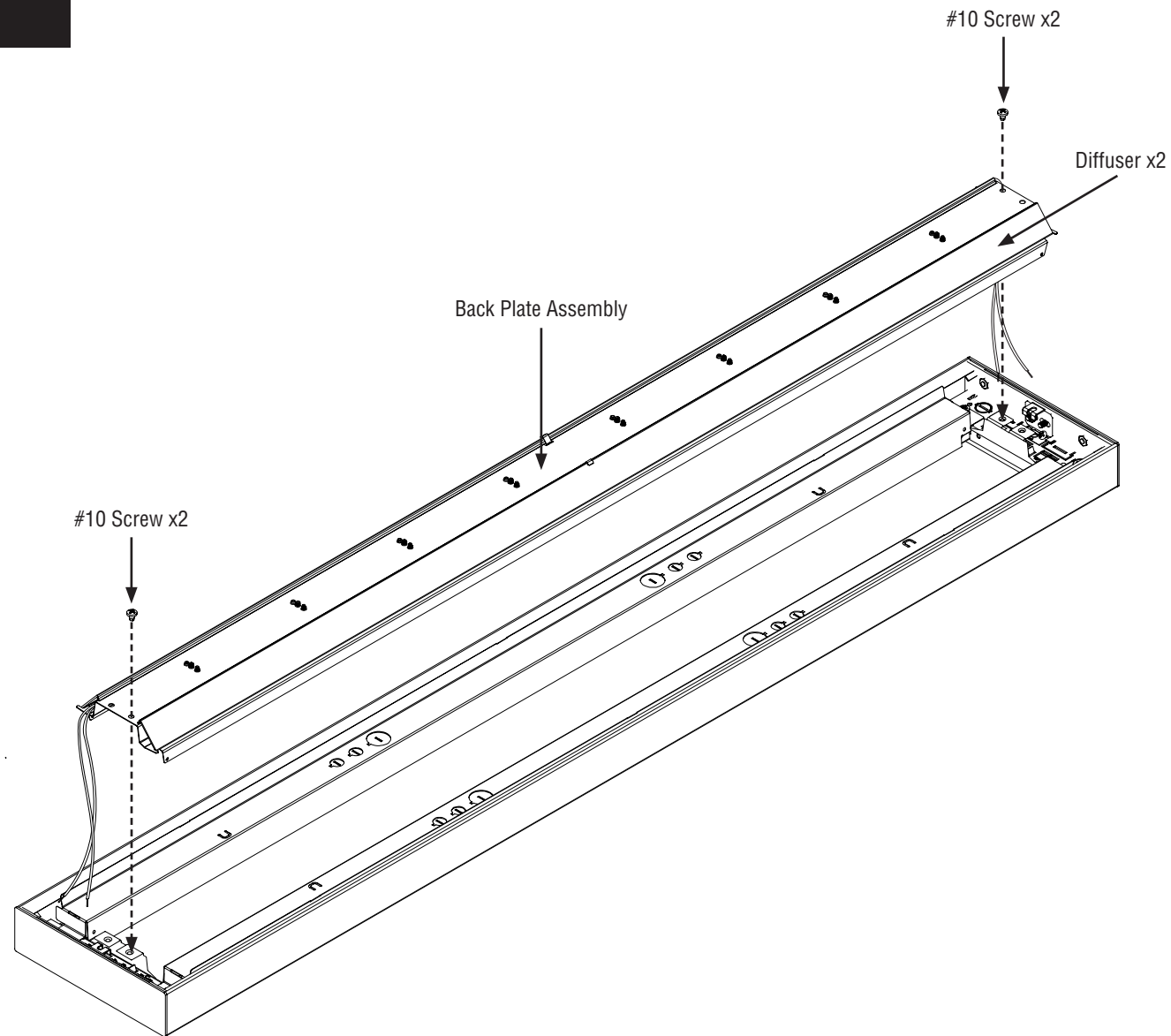

Remove #10 screws (2) from both ends of back plate assembly, then remove the back plate assembly. Remove diffusers (2) from back plate assembly.

Step 2

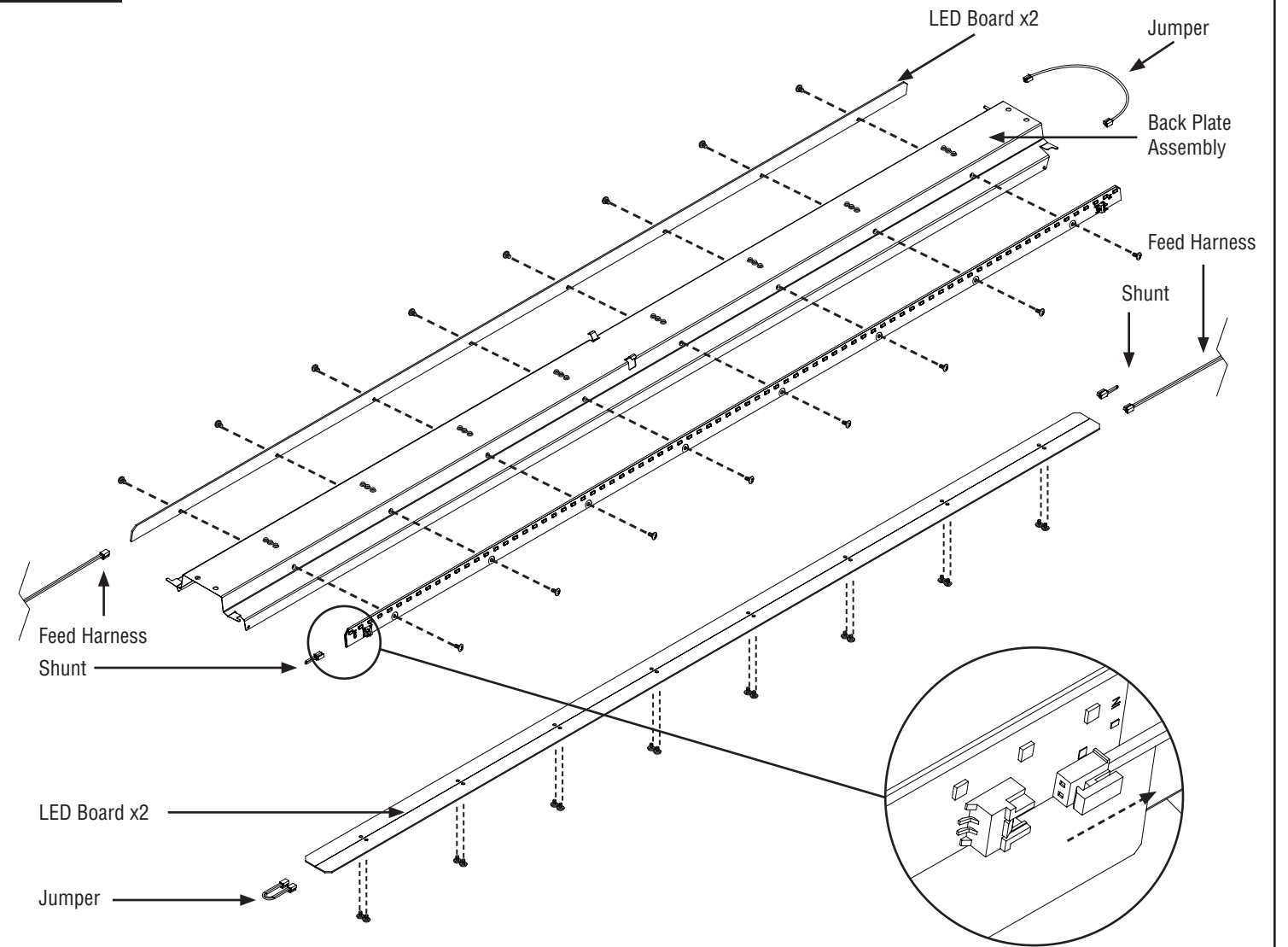

Disconnect all feed harnesses, jumpers, and shunts. Keep all cables and re-use with new LED engine. Remove #6 screws (24) from LED boards. Reassemble luminaire in reverse order. Turn power on to luminaire.