

# HP-4 Wall Wash Surface Mount T-Bar Starter/Independent Installation Instructions

Scan QR code for helpful video(s)



0 - 10V Dimming

### Step 1

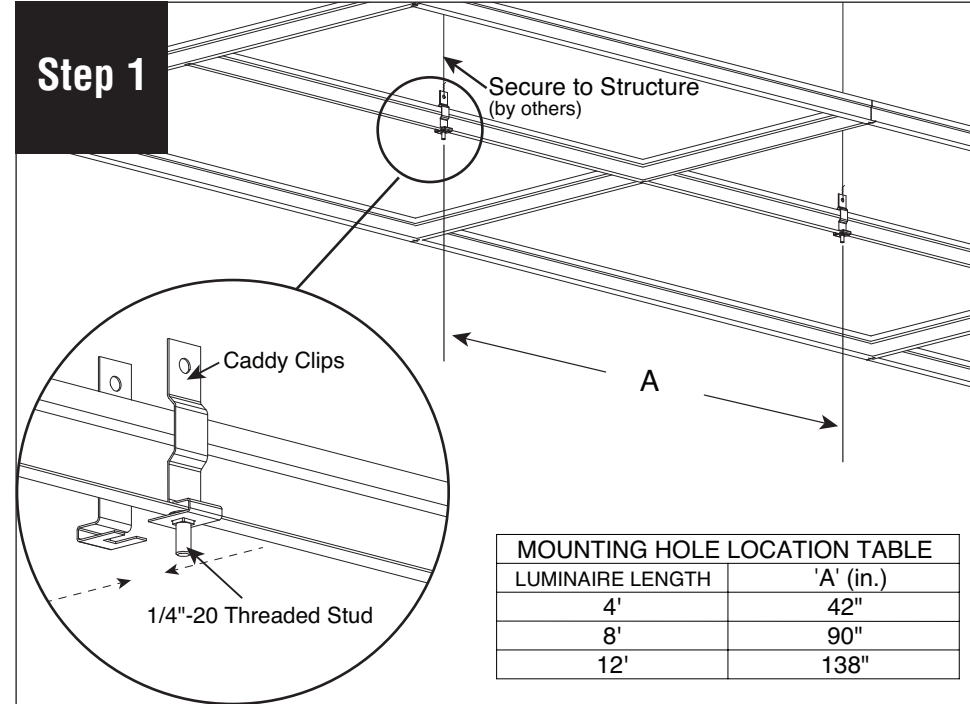

LUMINAIRE LENGTH	'A' (in.)
4'	42"
8'	90"
12'	138"

Install caddy clips accordingly. Secure luminaire to structure using tie-wire (by others) according to code.

### Step 2

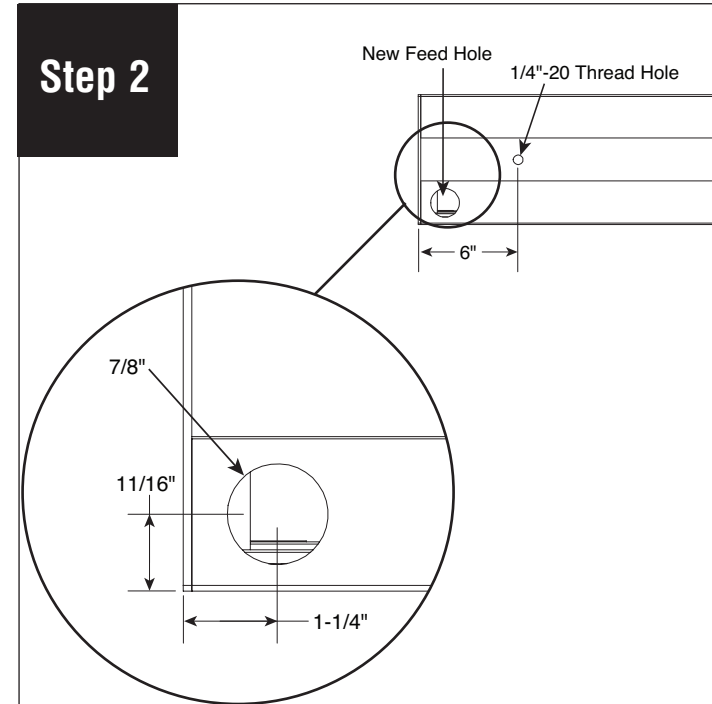

Note new feed hole on luminaire as indicated above.

### Step 3

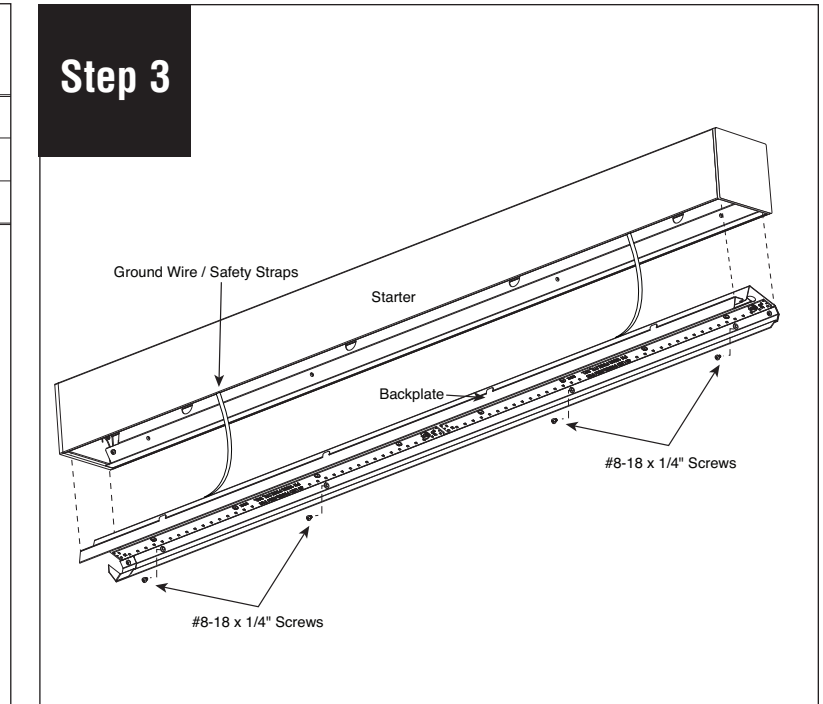

Remove diffuser from luminaire and set aside to prevent it from getting dirty or damaged. Remove backplate as a whole unit by removing 4 #8-18 x 1/4" screws.

### Step 4

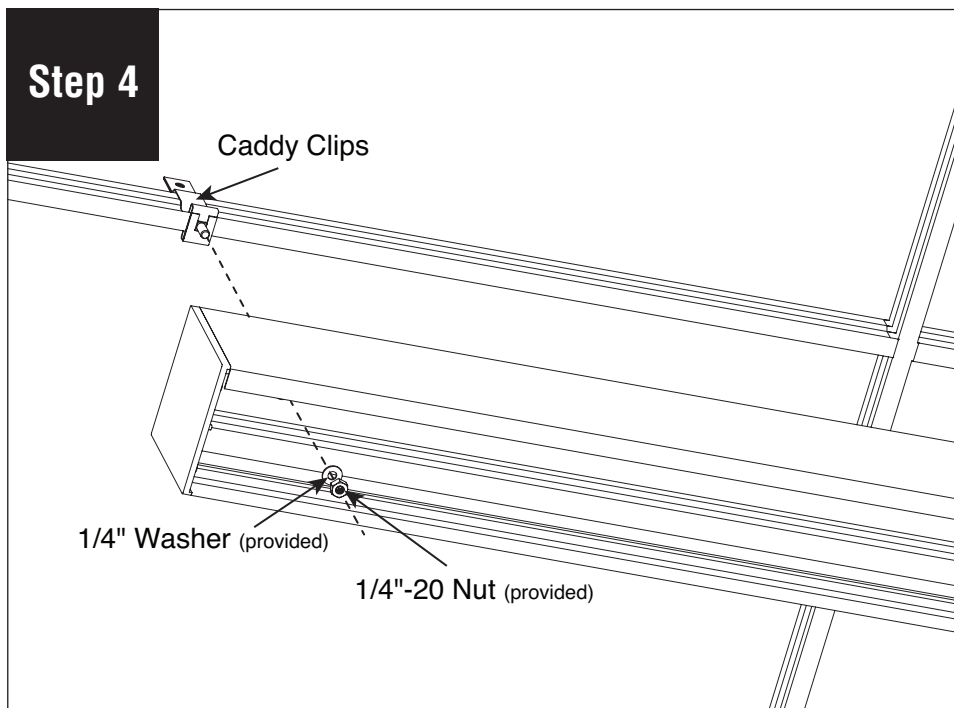

Install luminaire onto caddy clips using 1/4"-20 nut and 1/4" washer to attach to 1/4"-20 threaded stud. Repeat this step on the other end of the luminaire.

### Step 5

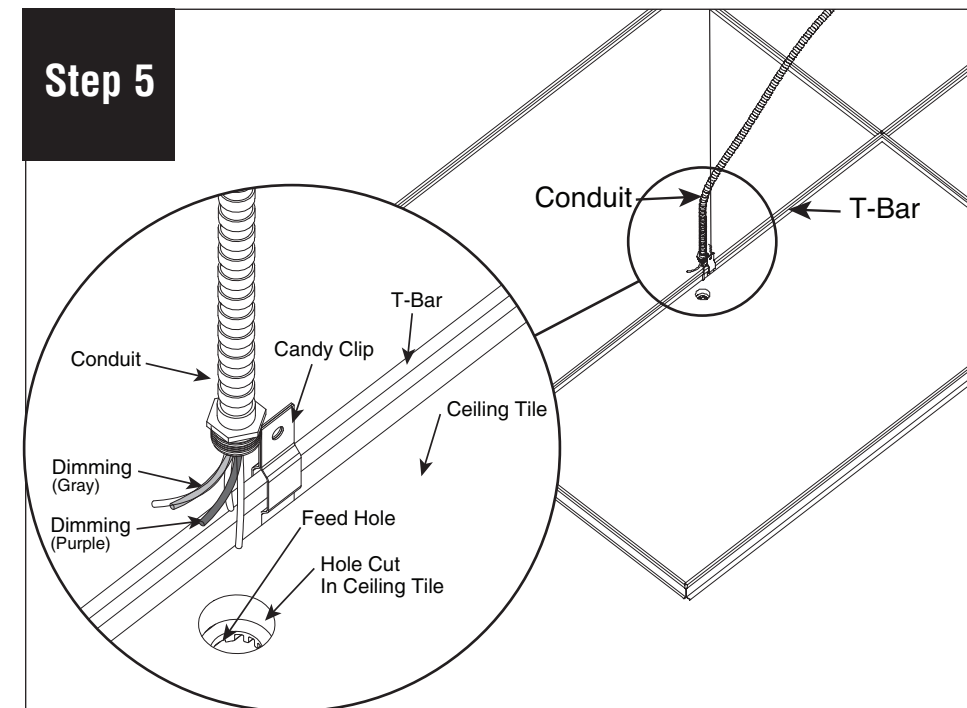

Cut hole in ceiling tile for conduit to pass through. Make sure hole aligns with feed hole shown in step 2. Insert wires and conduit through ceiling tile and into luminaire feed hole.

### Step 6

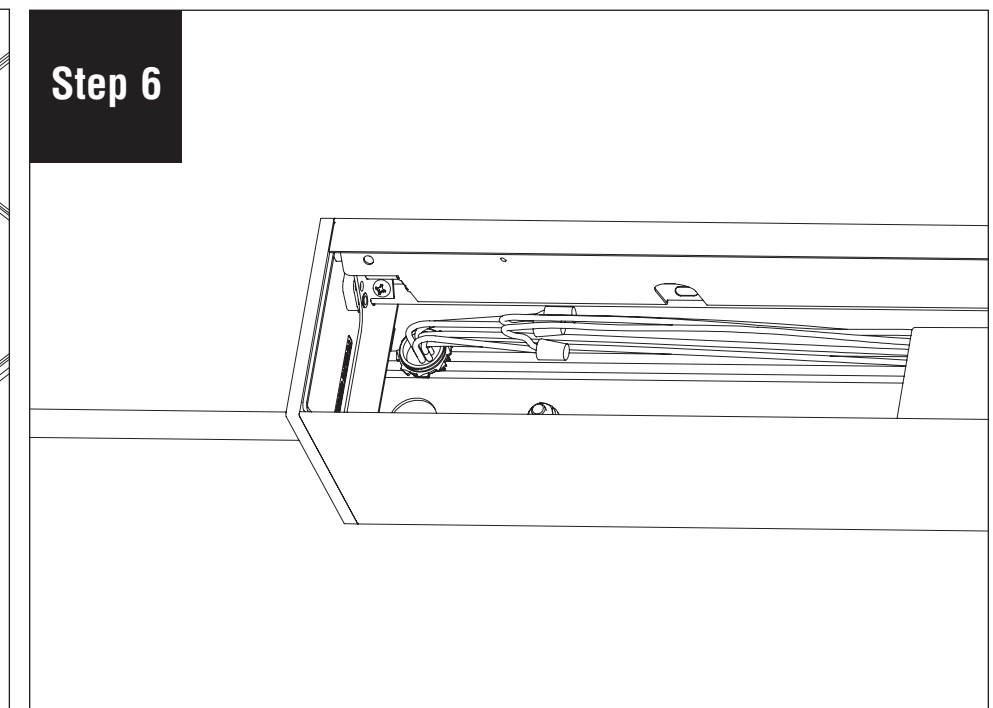

Make electrical connections.

**Note:** All power connections to be installed to local/national codes by a Certified Electrician.

# HP-4 Wall Wash Surface Mount T-Bar Starter/Independent Installation Instructions

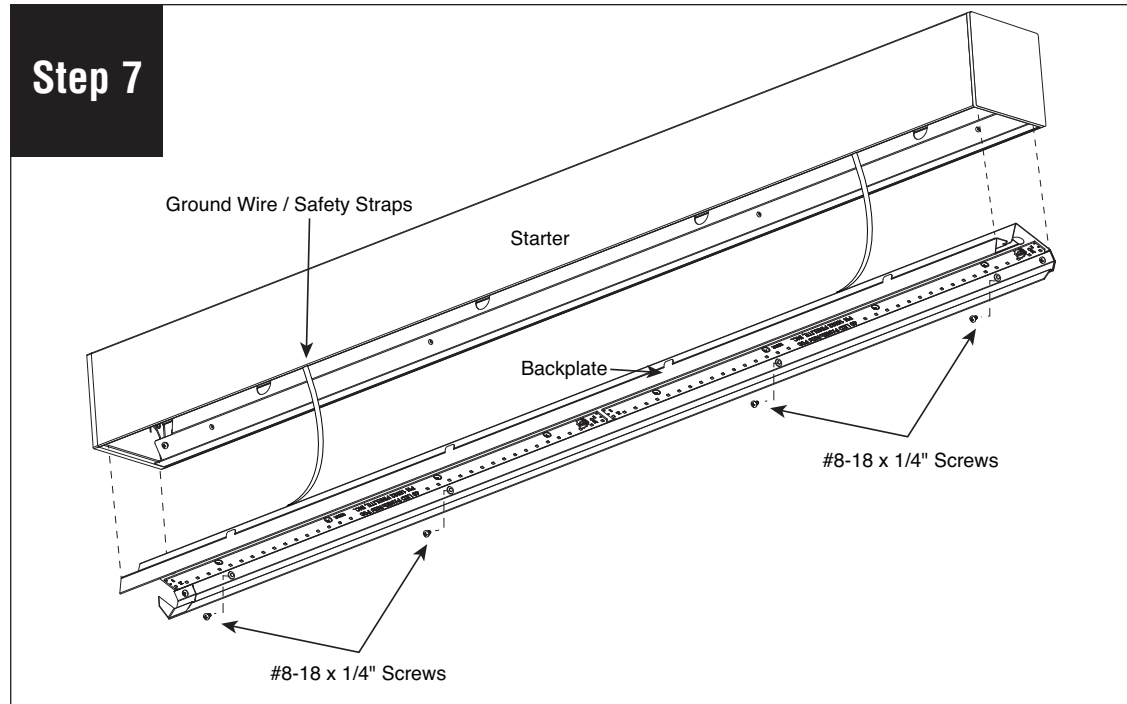

Replace backplate and secure with #8-18 x 1/4" screws.

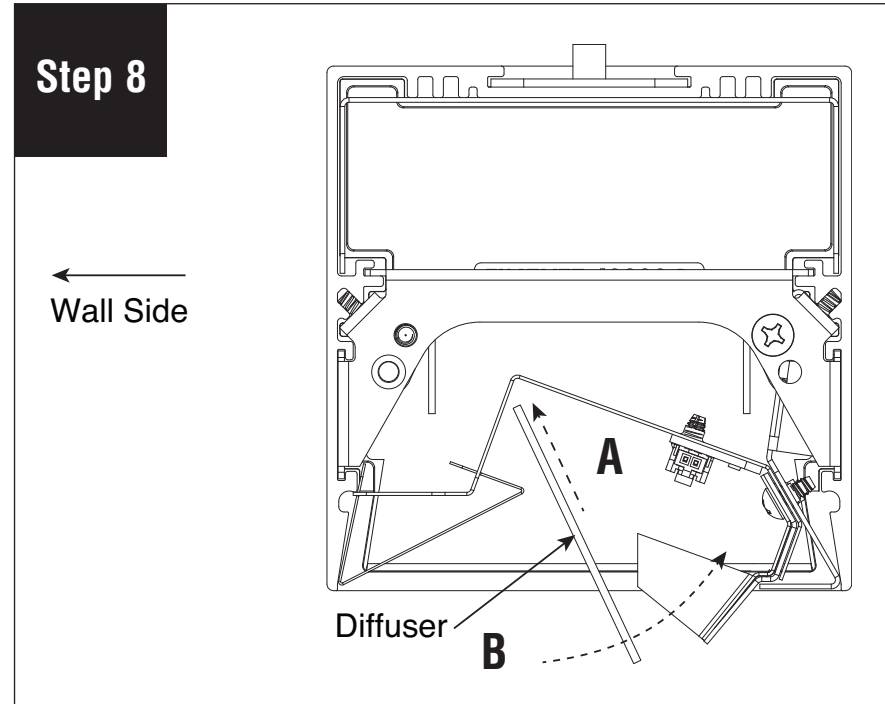

**A.** Slide diffuser into backplate. **B.** Push bottom edge of the diffuser into backplate. Turn power on to luminaire.

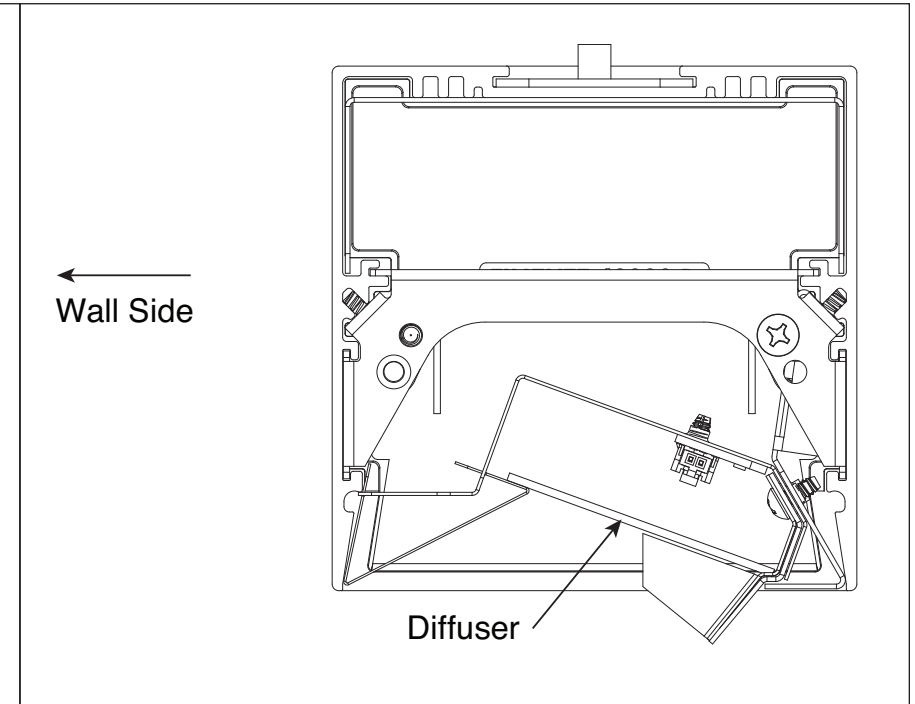

**Note:** All power connections to be installed to local/national codes by a Certified Electrician.

# HP-4 Wall Wash Surface Mount T-Bar Joiner/Ender Installation Instructions

Scan QR code for helpful video(s)



0 - 10V Dimming

## Step 1

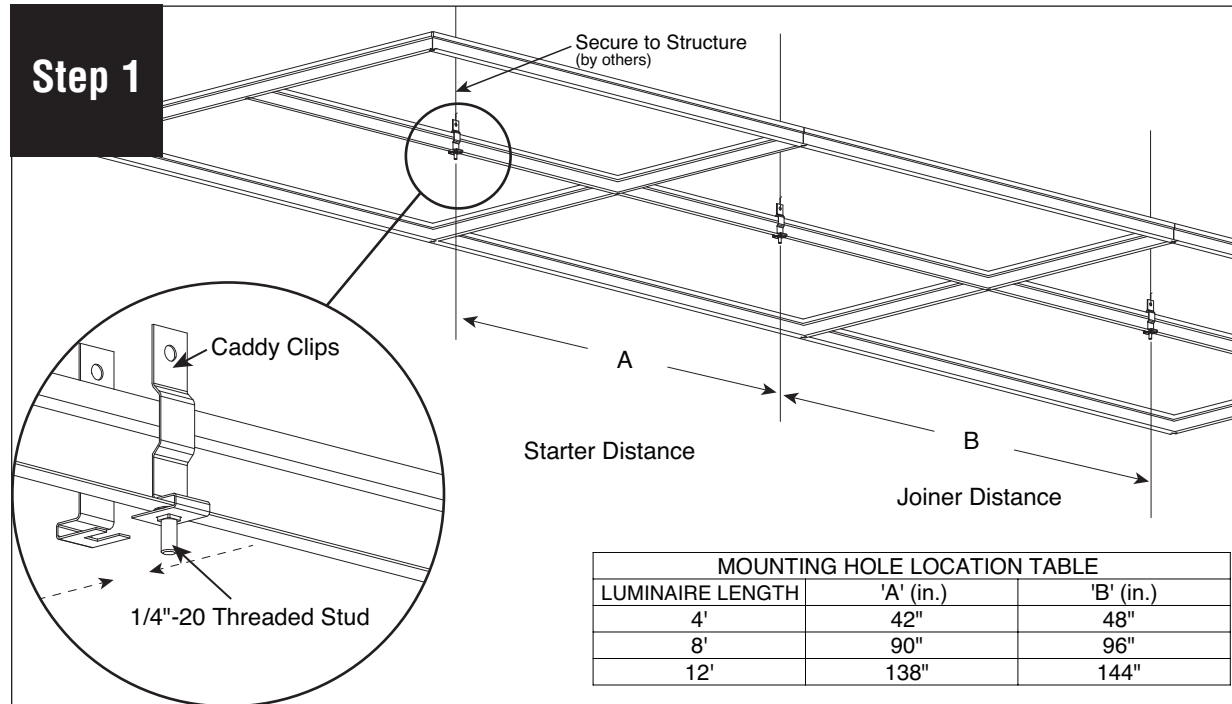

Install caddy clips accordingly. Secure luminaire to structure using tie-wire (by others) according to code.

## Step 2

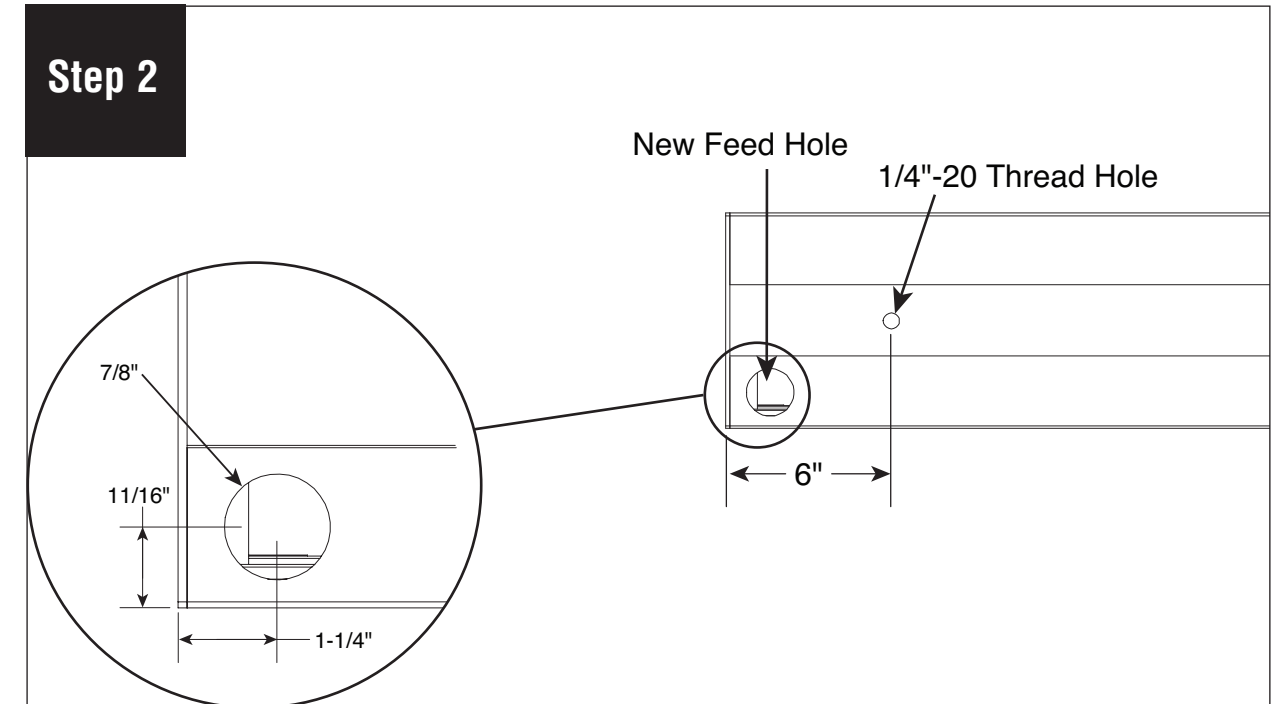

Note new feed hole on luminaire as indicated above.

## Step 3

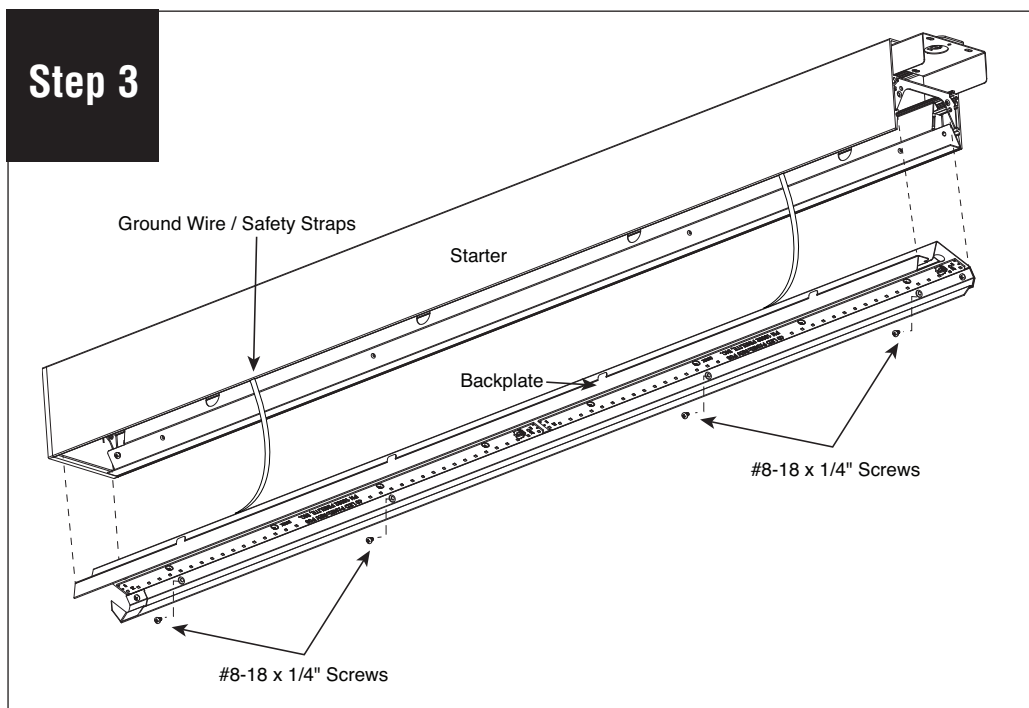

Remove diffuser from luminaire and set aside to prevent it from getting dirty or damaged. Remove backplate from starter as a whole unit by removing #8-18 x 1/4" screws (provided).

## Step 4

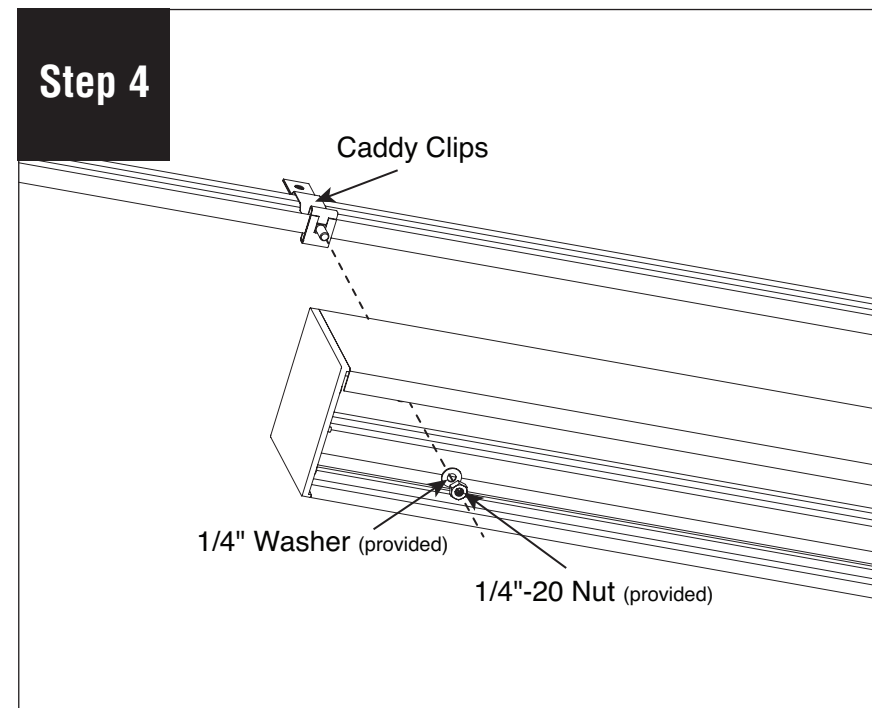

Install luminaire onto caddy clips using 1/4"-20 nut and 1/4" washer to attach to 1/4"-20 threaded stud. Repeat this step on the other end of the luminaire.

## Step 5

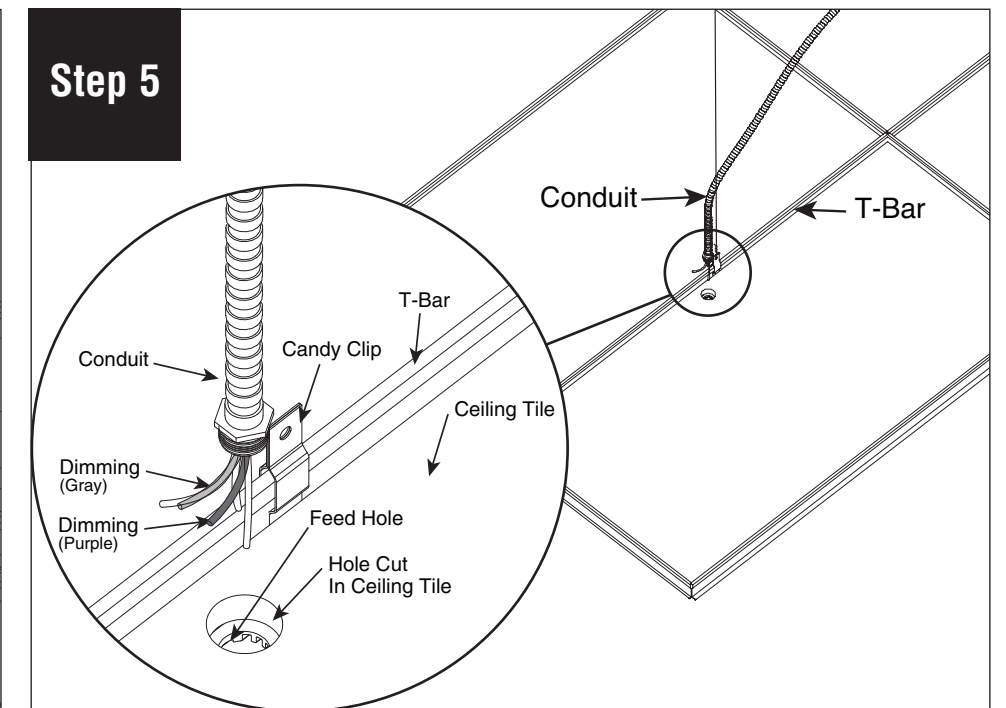

Cut hole in ceiling tile for conduit to pass through. Make sure hole aligns with feed hole shown in step 2. Insert wires and conduit through ceiling tile and into luminaire feed hole.

**Note:** All power connections to be installed to local/national codes by a Certified Electrician.

# HP-4 Wall Wash Surface Mount T-Bar Joiner/Ender Installation Instructions

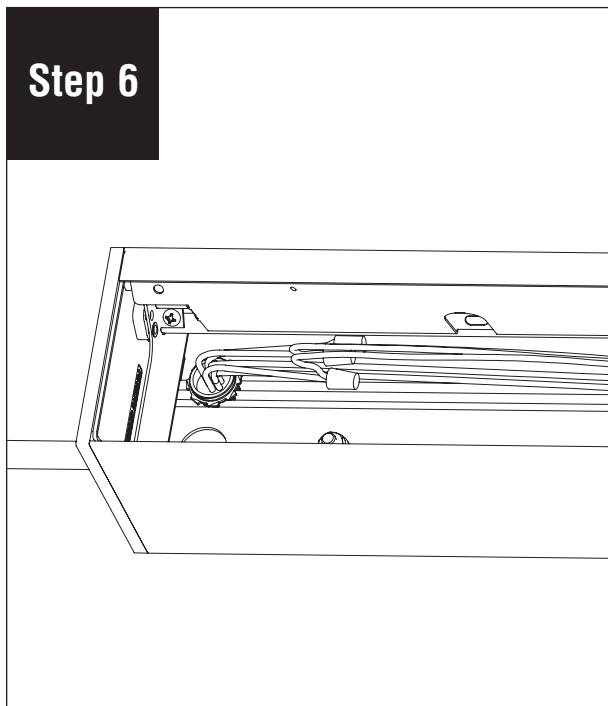

Step 6  
Make electrical connections.

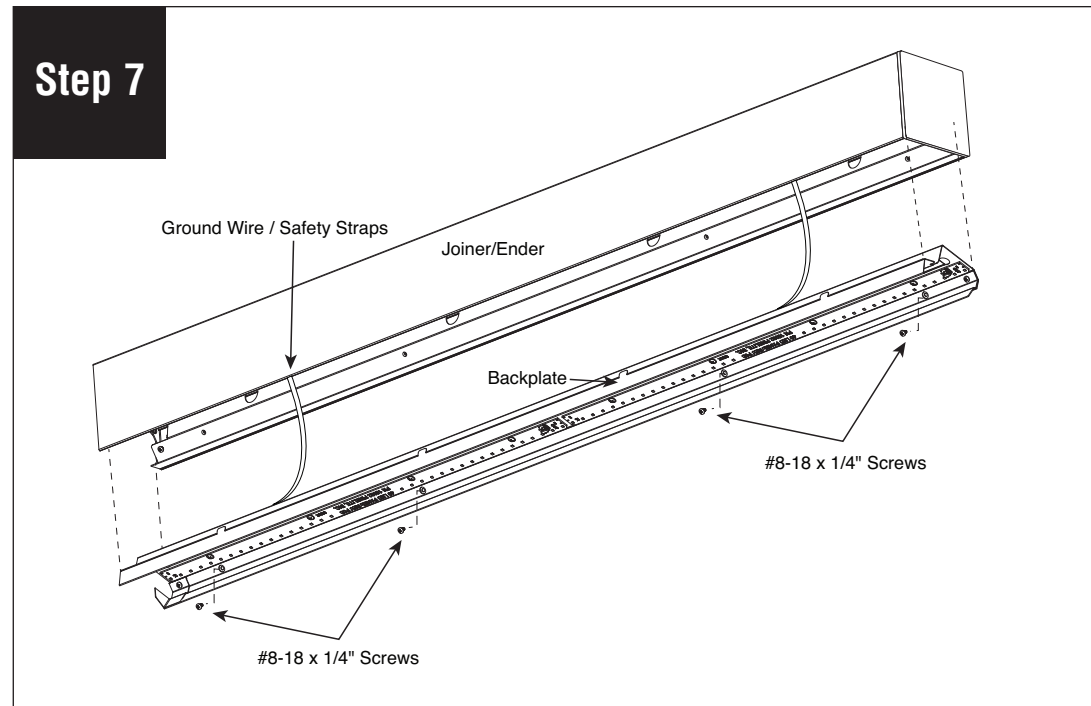

Step 7  
Remove backplate from joiner/ender as a whole unit by removing #8-18 x 1/4" screws (provided).

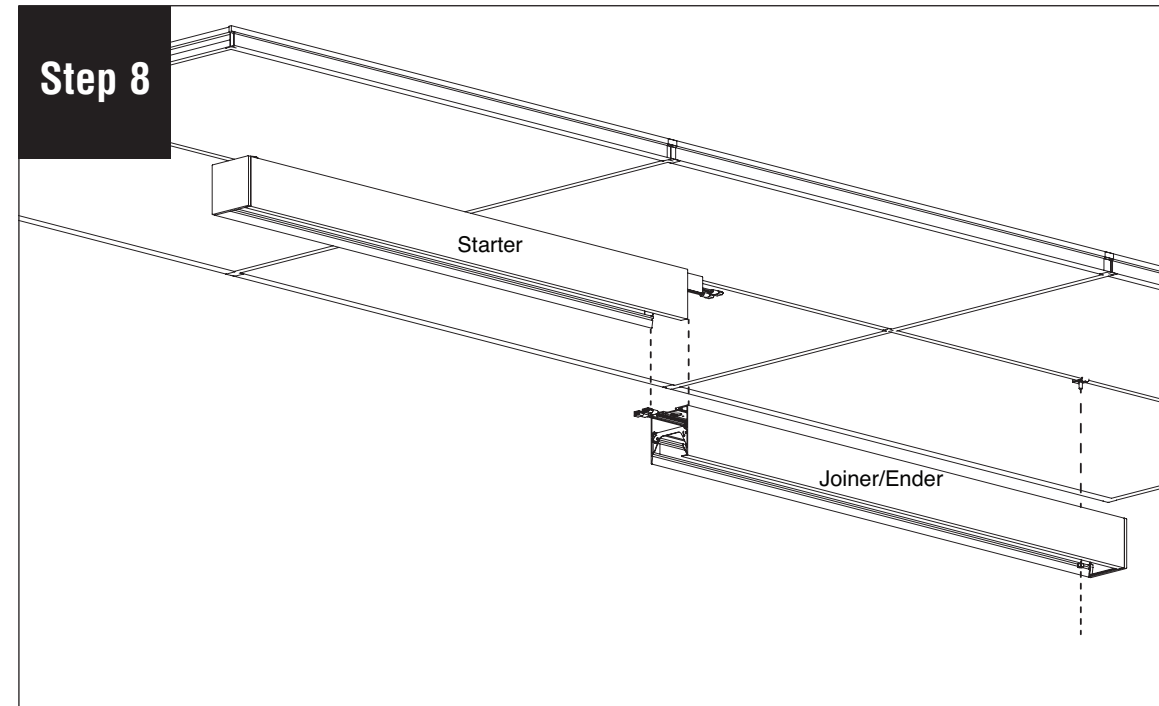

Step 8  
Align starter and joiner/ender.

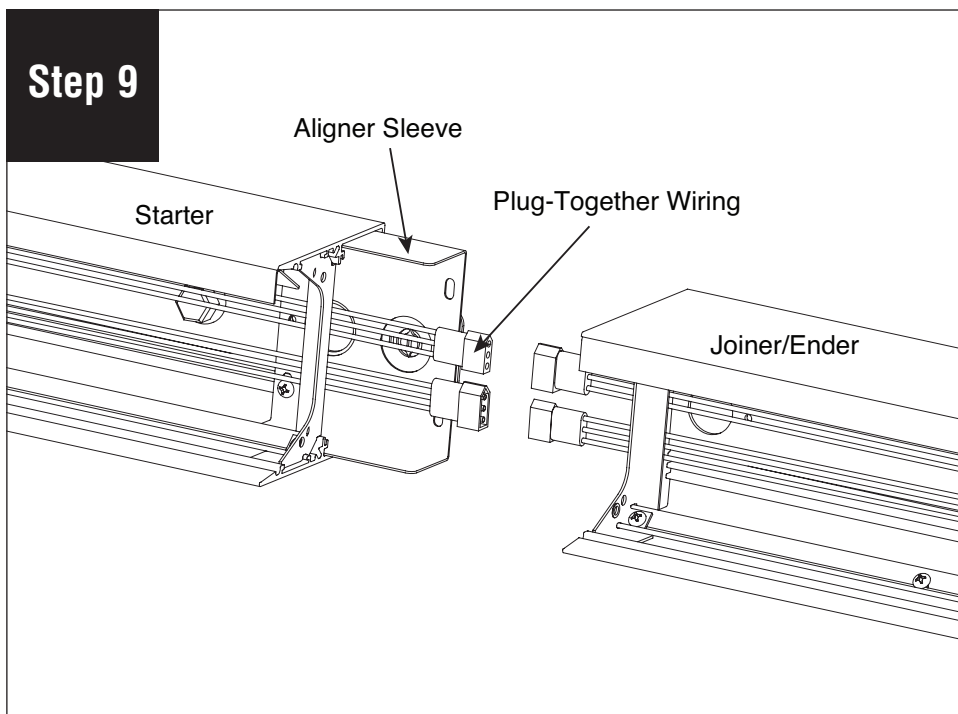

Step 9  
Connect plug-together wiring.

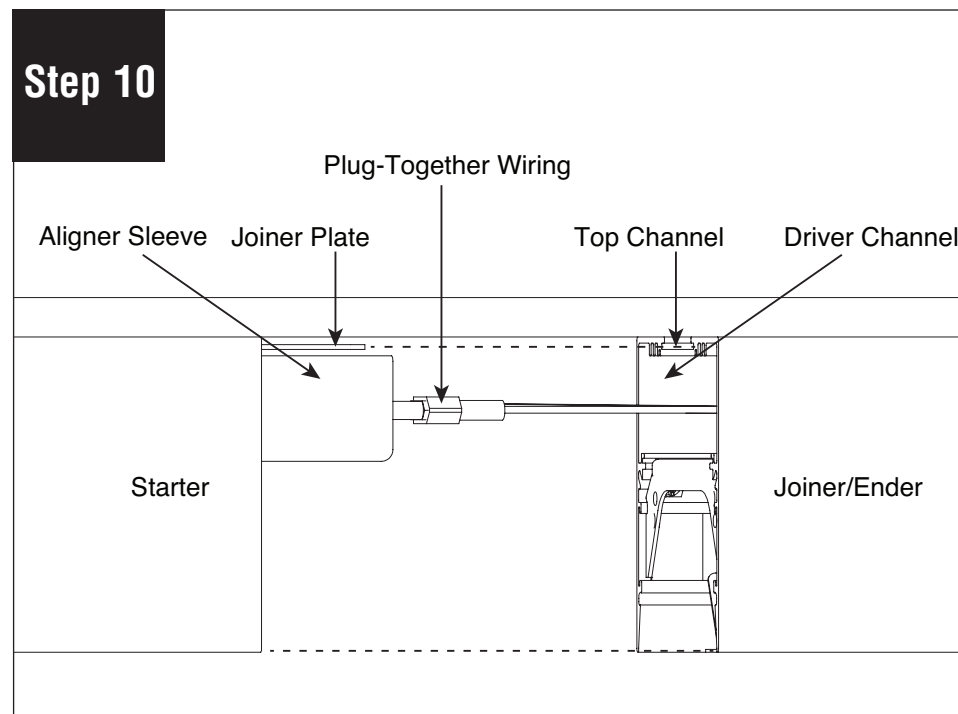

Step 10  
Line up aligner sleeve with driver channel and joiner plate with top channel then slide joiner/ender toward starter. Be careful not to damage any wiring.

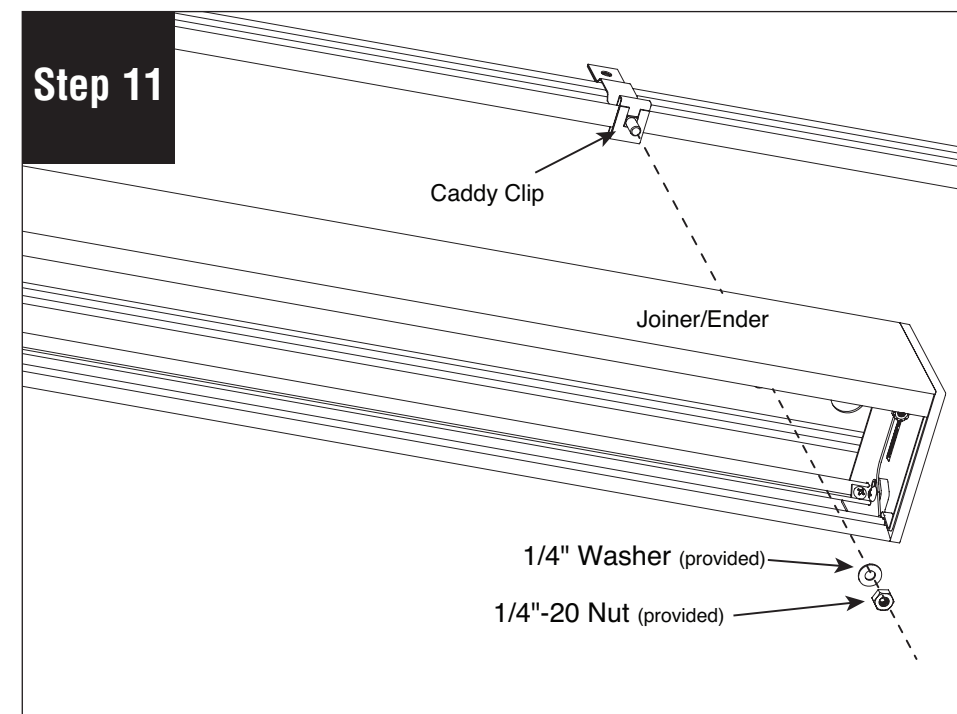

Step 11  
Install 1/4" washers and 1/4"-20 nuts onto 1/4"-20 threaded stud in caddy clip.

Protected by one or more US Patents: 8915613; D702,391; D702,390; D700,732

**Note:** All power connections to be installed to local/national codes by a Certified Electrician.

# HP-4 Wall Wash Surface Mount T-Bar Joiner/Ender Installation Instructions

Step 12

**IMPORTANT STEP**

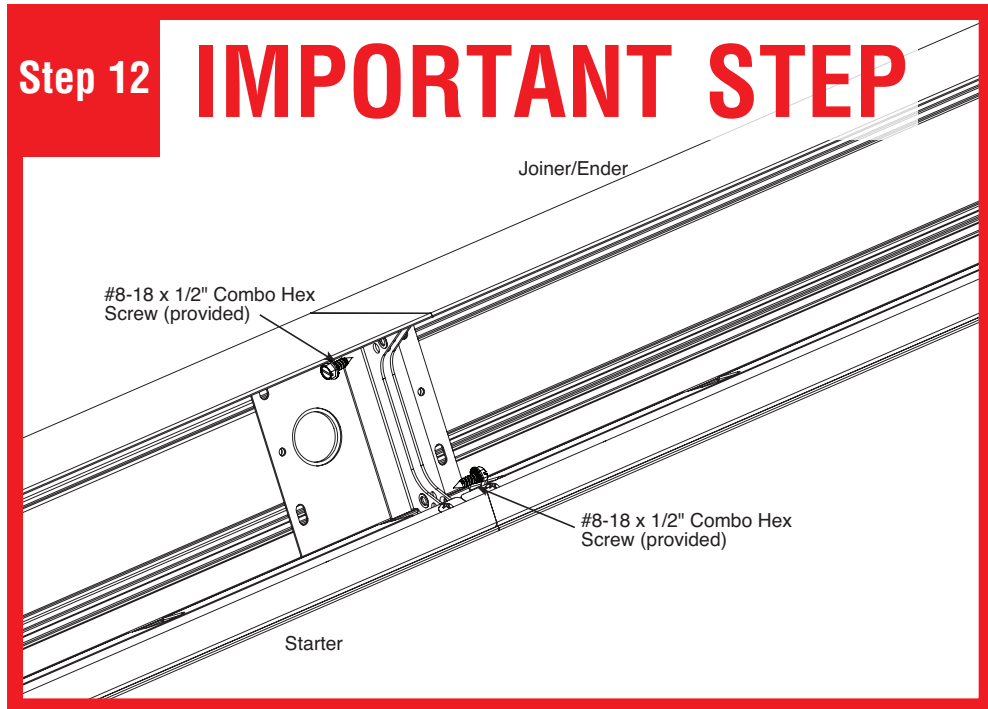

**IMPORTANT STEP:** Secure joint with two #8-18 x 1/2" combo hex screws (provided) as shown. Screws can be installed from the left or right. **CAUTION: Do not over-tighten.**

Step 13

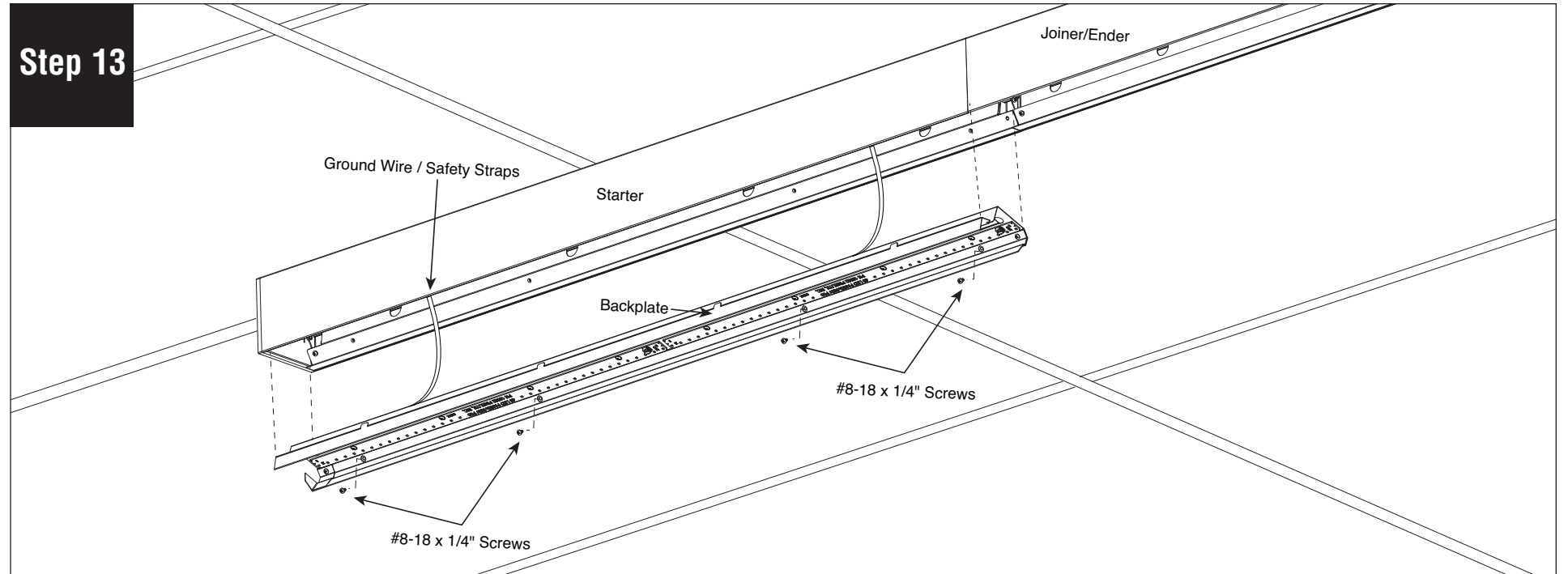

Replace backplates to starter and joiner/ender and secure with #8-18 x 1/4" screws (provided).

Step 14

**IMPORTANT STEP**

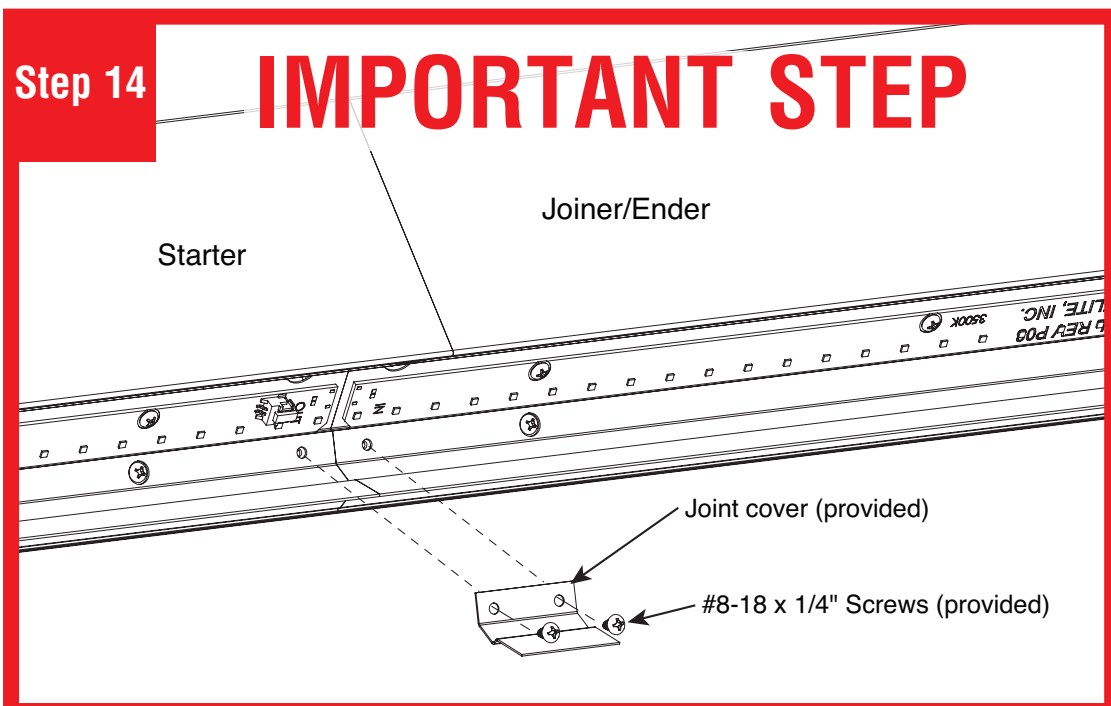

Install joint cover (provided) between starter and joiner/ender backplates with #8-18 x 1/4" screws.

Step 15

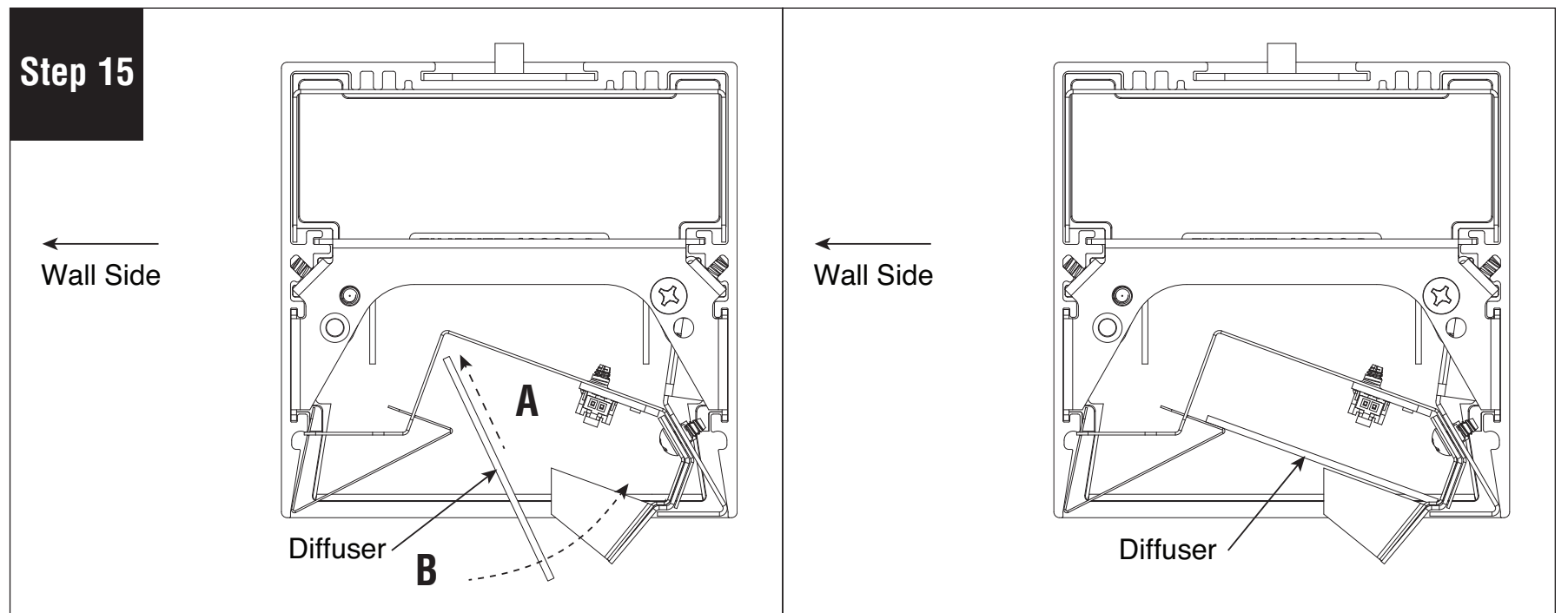

**A.** Slide diffuser into backplate. **B.** Push bottom edge of the diffuser into backplate. Turn power on to luminaire.

**Note:** All power connections to be installed to local/national codes by a Certified Electrician.