

H04 Uplight/Downlight

H04-UD Recycling Luminaire Disassembly Instructions

Luminaire breaks down easily for recycling at the end of usable life*.

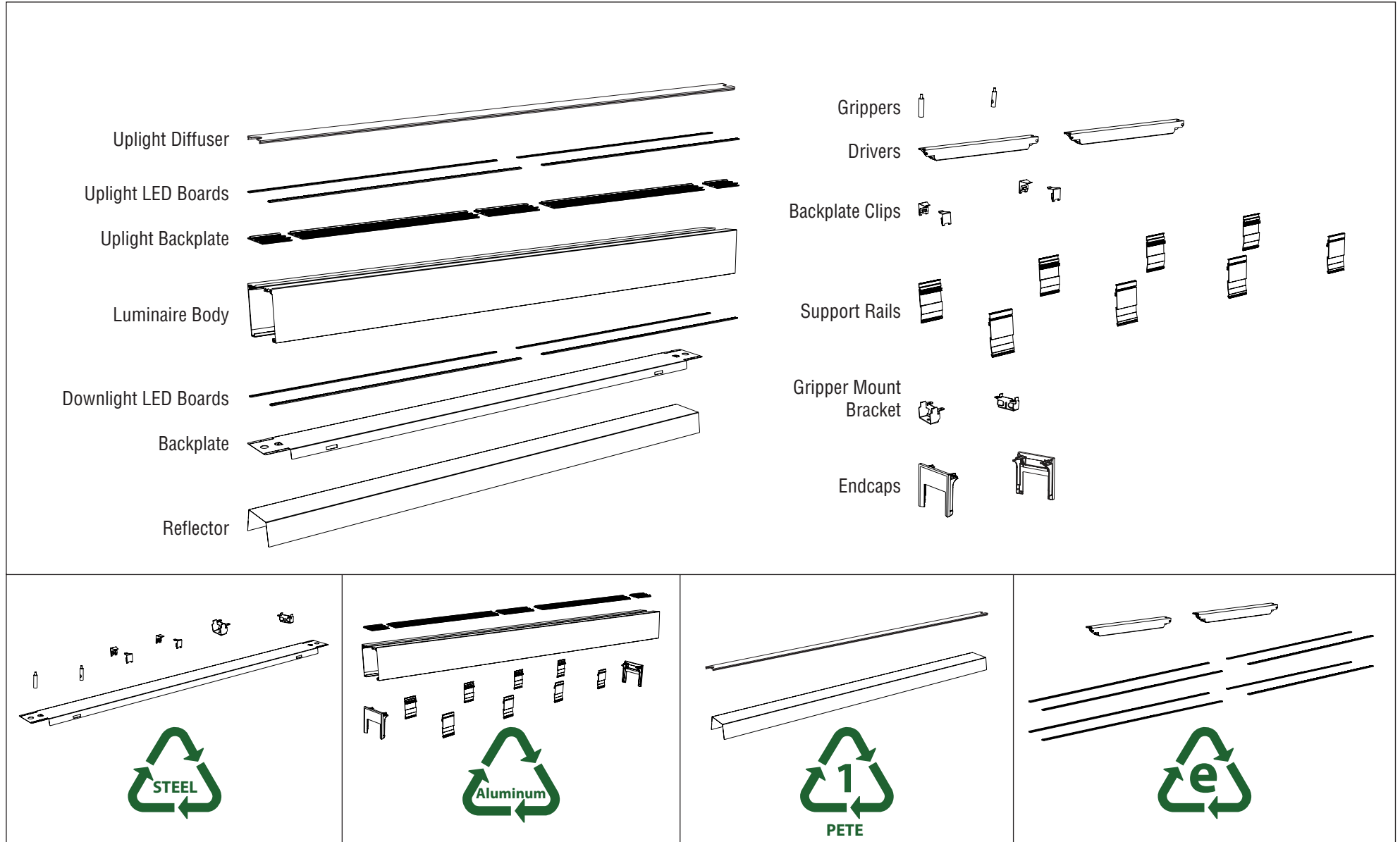

*Recycling information typical for all luminaire sizes. Contact factory for more information.

Due to continuing improvements, Finelite reserves the right to change specifications without notice. Please visit www.finelite.com for most current data.

H04 Uplight/Downlight

H04-UD Recycling Luminaire Breakdown

100% Recyclable

H04-UD components are constructed from aluminum, steel, e-waste, and plastic. H04-UD is 100% recyclable at the end of useful life.

