

# HP-WG Wall Bracket Mount Spackle Flange Installation Instructions

## Overview

### NOTES

- All power connections should be installed according to local/national codes by a Certified Electrician.
- This installation requires **proper support** as each luminaire is being installed.
- **DO NOT attempt to join luminaires together on the floor.** Damage may result when lifted.



HELPFUL  
VIDEO



0-10V  
Dimming



Simple  
Plug-Together  
Wiring

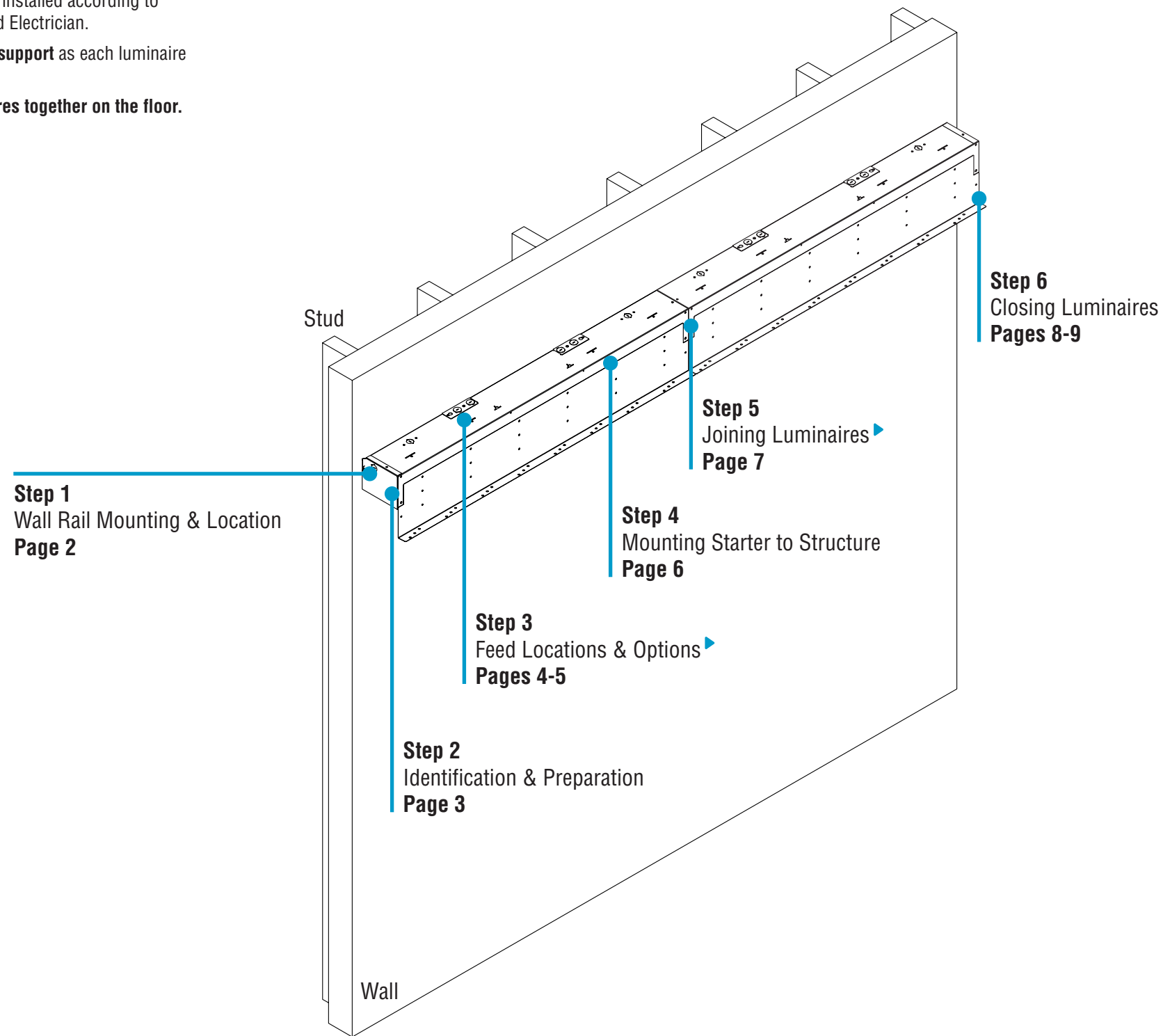

# HP-WG Wall Bracket Mount Spackle Flange Installation Instructions

## Step 1 - Wall Rail Mounting & Location

### A. Wall Rail Location Front View

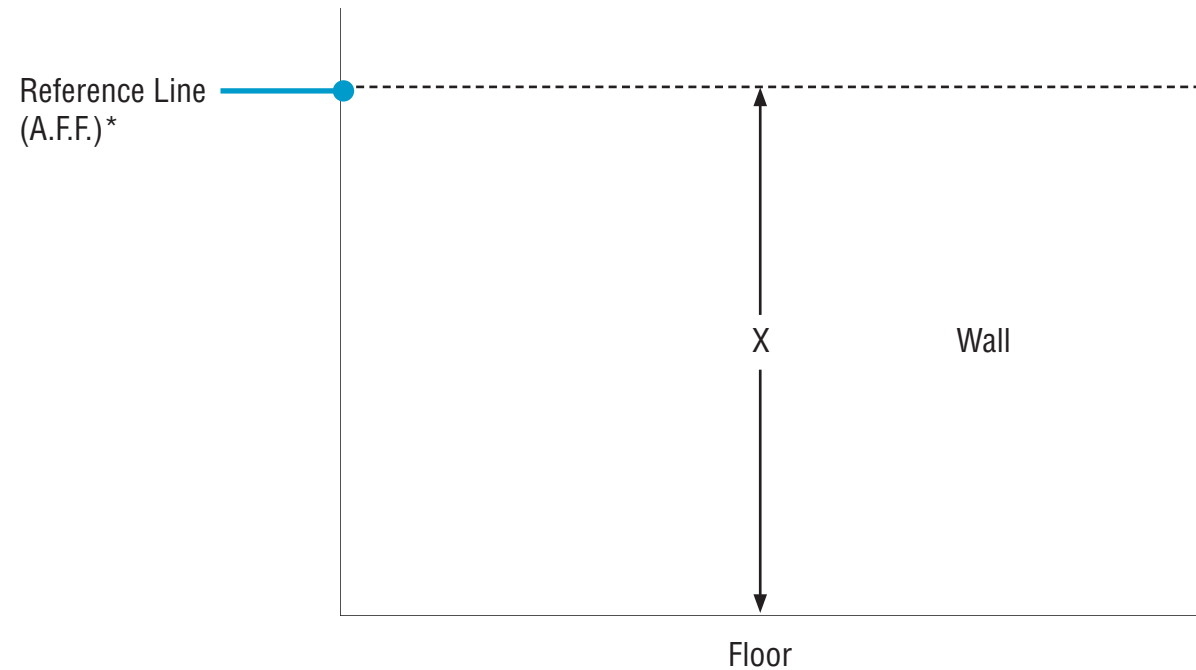

	Height from Bottom of the Wall Rail
Luminaire Depth	X (in)
2"	Ceiling Height A.F.F. + 2-1/8
4"	Ceiling Height A.F.F. + 4-1/8
6"	Ceiling Height A.F.F. + 6-1/8

- **NOTE:** Tolerances on dimensions are  $\pm 1/16"$
- Use provided table to measure wall rail height and mark it on all walls.

\*A.F.F.: Above Finished Floor

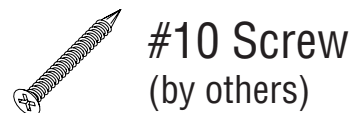

### B. Mounting Wall Rail Side View

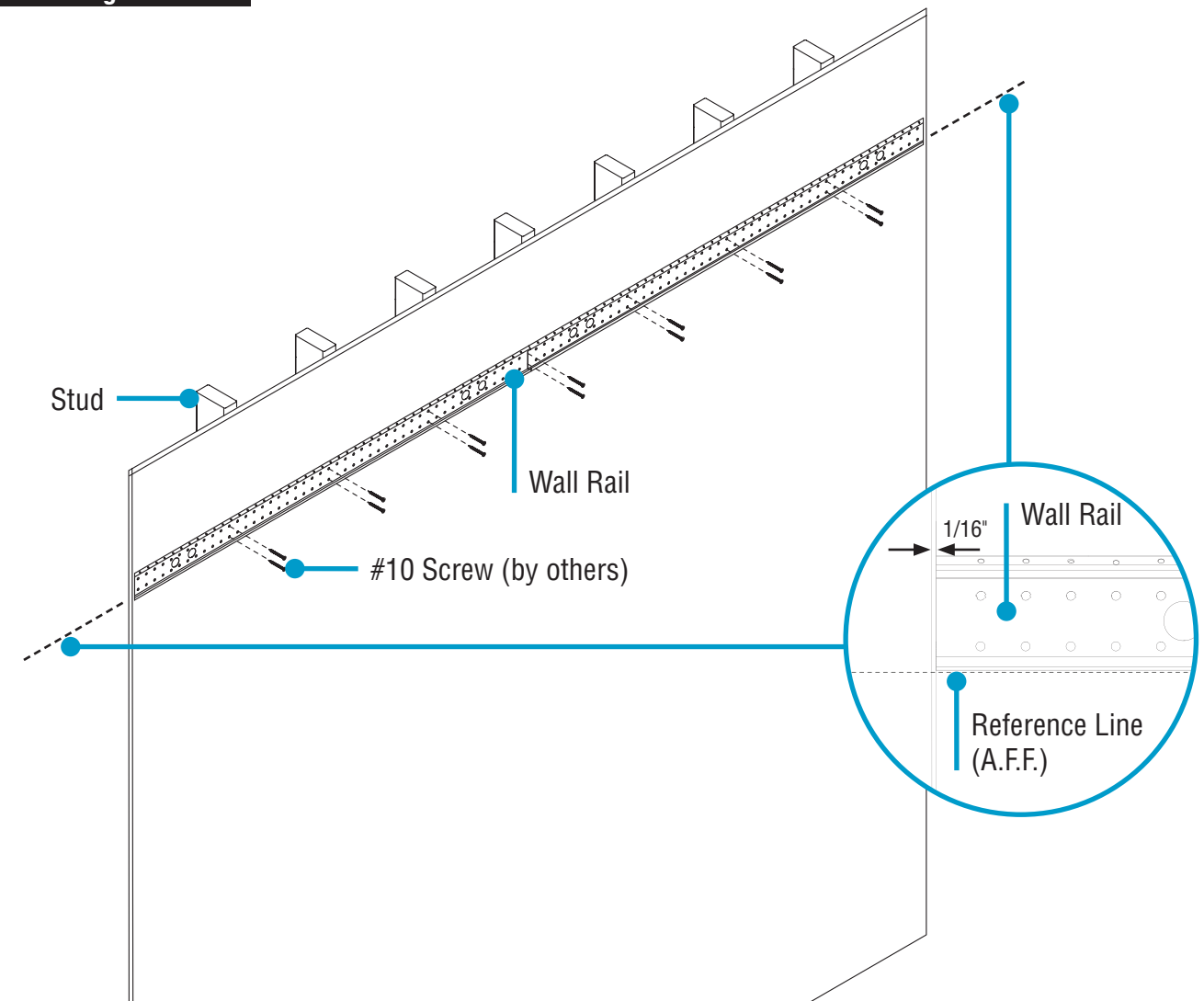

- Use appropriate #10 screws to secure wall rails to wall studs.

# HP-WG Wall Bracket Mount Spackle Flange Installation Instructions

## Step 2 - Identification & Preparation

### A. Identify Luminaires



**CAUTION**

Arrange luminaires in order according to ID# at their install locations.

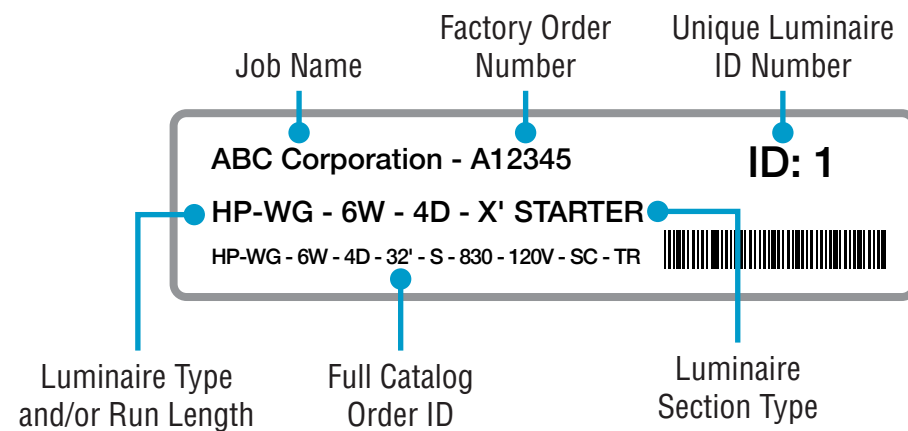

Bottom-Up View

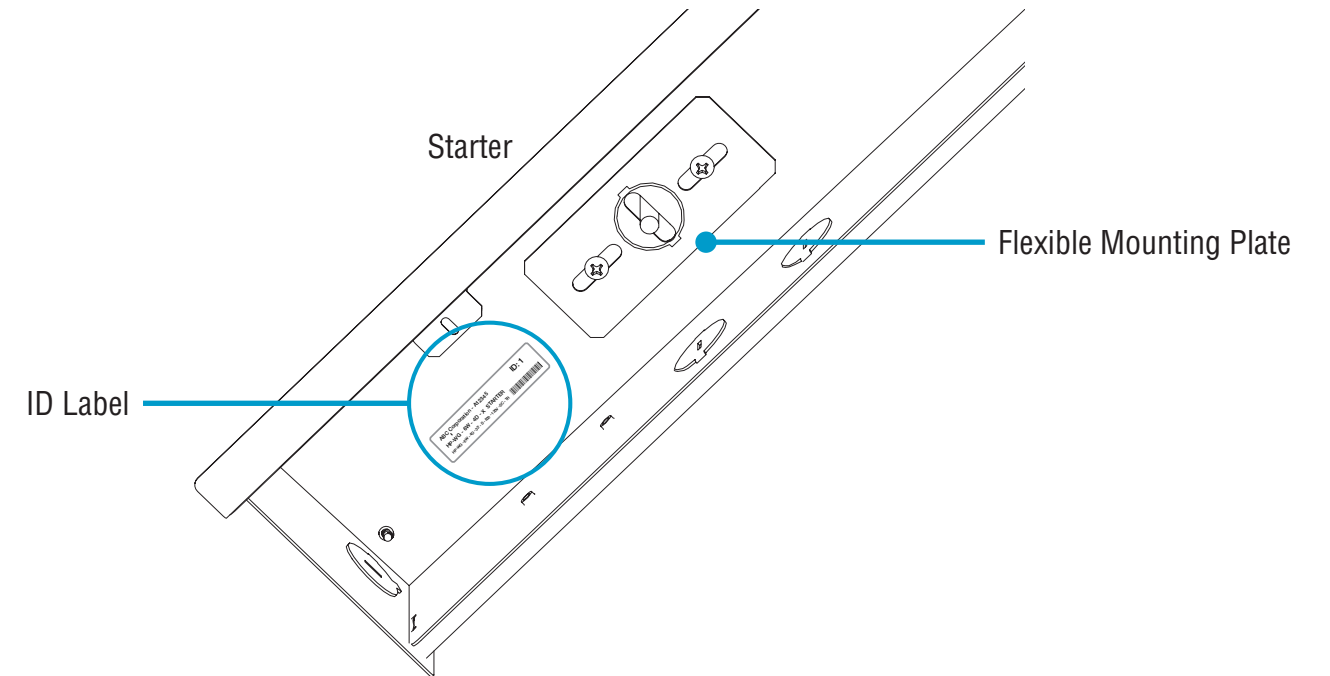

- Identify all luminaires by their ID label that can be found on the box and inside the luminaire.
- **NOTE:** Exact location of labels in these areas may vary.
- Remove all luminaires from their box.
- Refer to Record Drawings that can be found in the hardware kit.

### Kitted Hardware

- Finelite has provided items listed here, with their Finelite part numbers. These items can be found in separate boxes shipped with the luminaire.
- Account for all parts and set aside until they are needed.
- All other hardware needed for this installation will be by others.



**#8-18 x 1/4" Screw**  
Part# 69026  
Feed Locations & Options  
p. 4, Step 3  
Mounting Starter to Structure  
p. 6-7, Step 4  
Joining Luminaires  
p. 8, Step 5  
Closing Luminaires  
p. 9, Step 6



**#10-32 Screw**  
Part# 94144  
Feed Locations & Options  
p. 4, Step 3





**Cover Sleeve**  
Part# 10719  
Closing Luminaires  
p. 9, Step 6

# HP-WG Wall Bracket Mount Spackle Flange Installation Instructions

## Step 3 - Feed Locations & Options

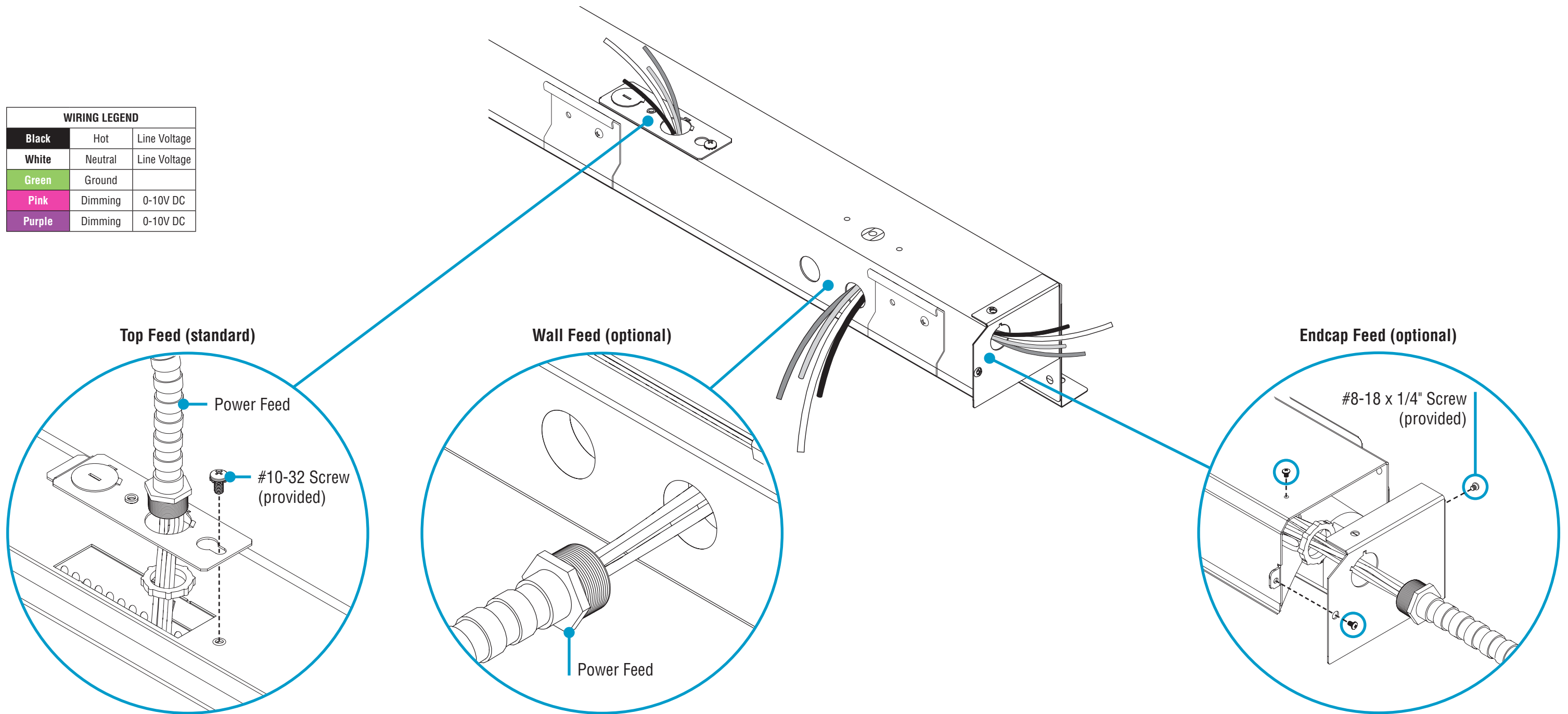
WIRING LEGEND		
Black	Hot	Line Voltage
White	Neutral	Line Voltage
Green	Ground	
Pink	Dimming	0-10V DC
Purple	Dimming	0-10V DC



 #8-18 x 1/4" Screw (provided)

 #10-32 Screw (provided)

CONTINUED



0-10V Dimming

# HP-WG Wall Bracket Mount Spackle Flange Installation Instructions

## Step 3 - Feed Locations & Options

**Top Feed** Top View

Luminaire Length	C (in)
2'	5
3'	5
4'	12
8'	12

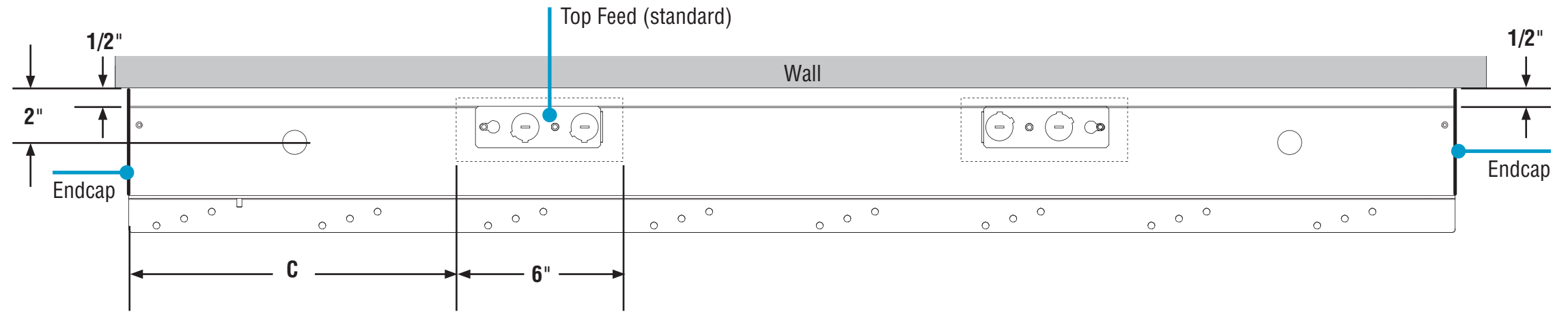

**Top Feed Location (standard)**

- Use chart above to find measurement of C for feed location.
- **NOTE:** For tailored length luminaire power feed locations, contact factory.

**Wall Feed** Back View

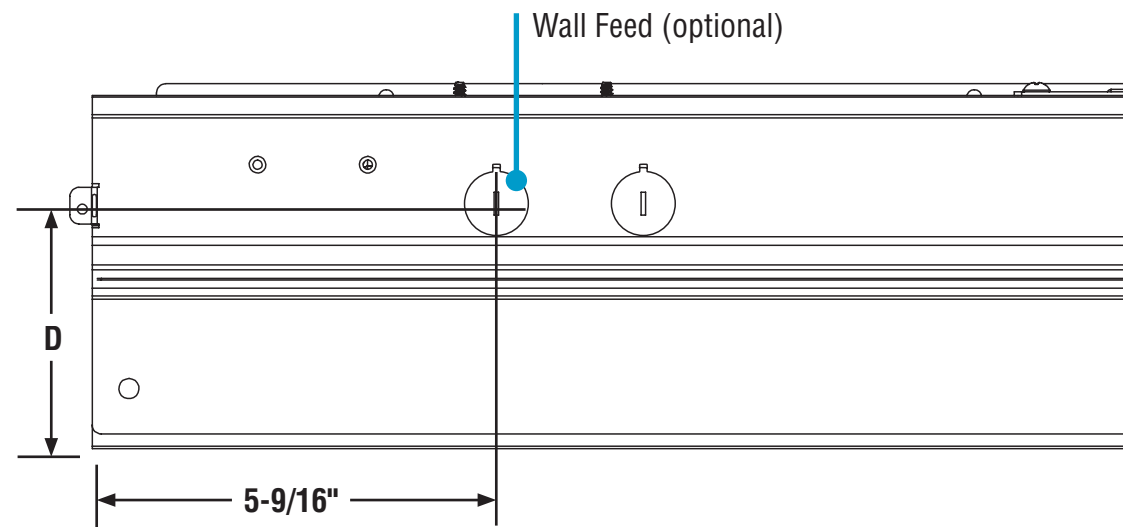

Luminaire Depth	D (in)
2"	3-5/16
4"	5-5/16
6"	7-5/16

**Endcap Feed** Side View

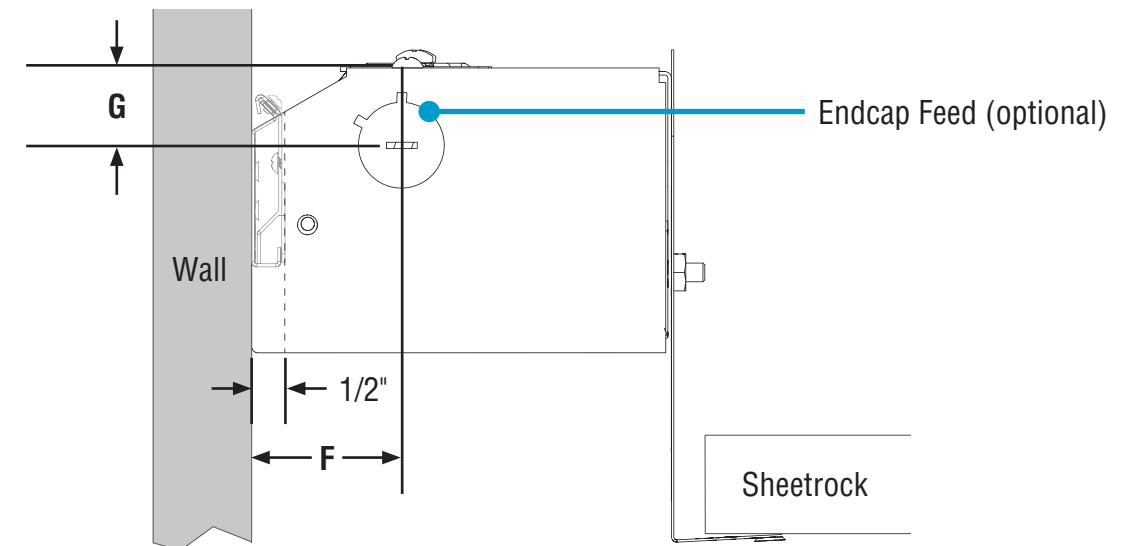

Luminaire Width	F (in)	G (in)
6"	2	13/16

# HP-WG Wall Bracket Mount Spackle Flange Installation Instructions

## Step 4 - Mounting Starter to Structure

### A. Mount Luminaire Side View

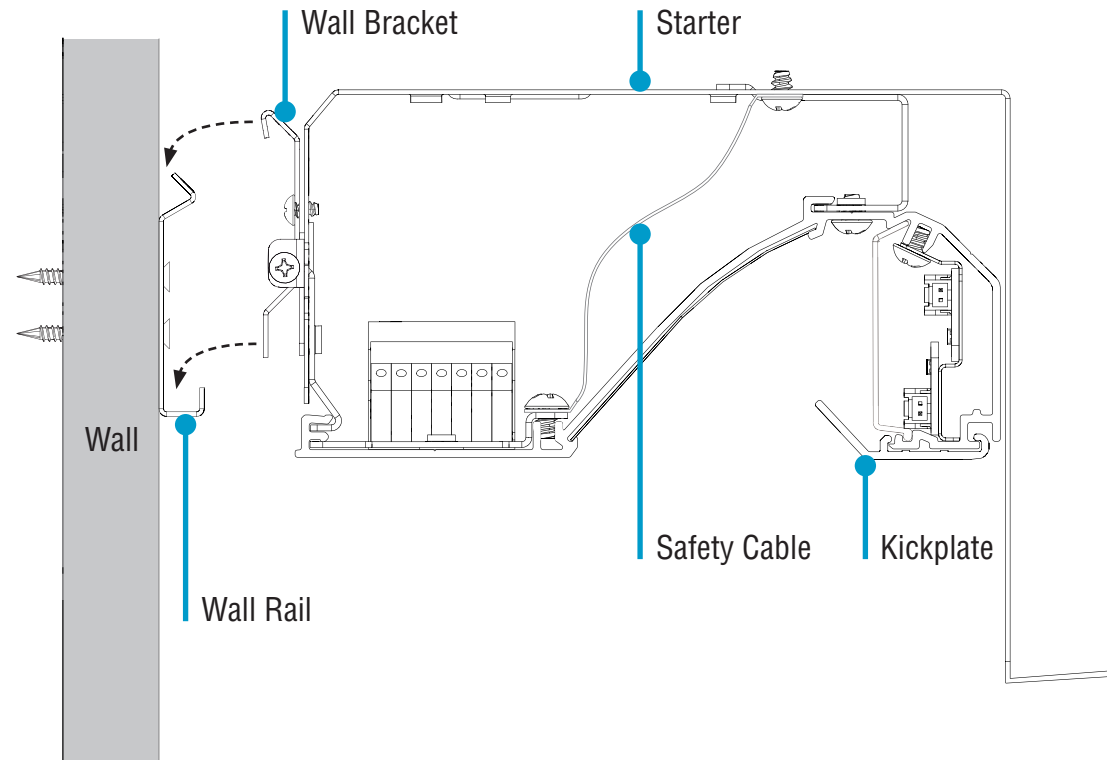

- Make electrical connections according to feed location and options.
- Mount starter luminaire to wall rail by ensuring wall bracket grabs top of wall rail.
- Align end of starter luminaire to start of main wall rail.

### B. Secure Luminaire Side View

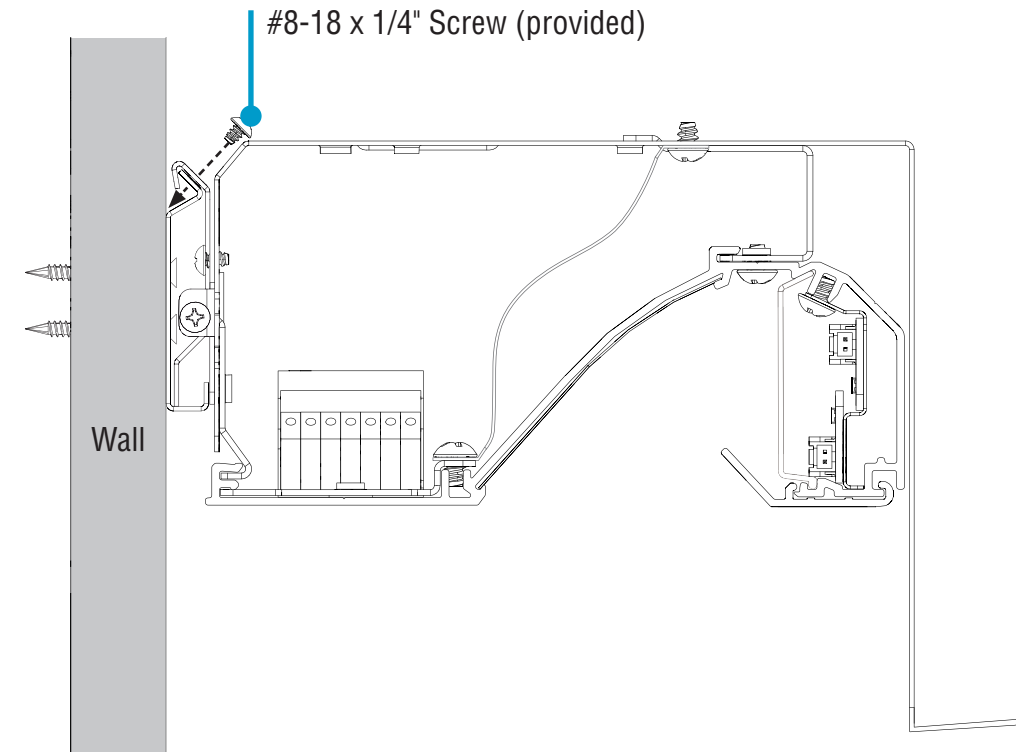

- Secure starter luminaire to wall rail with #8-18 x 1/4" screw through wall bracket.
- If there is no joiner/ender, then tighten fully. **PROCEED TO STEP 6.**

 #8-18 x 1/4" Screw  
(provided)

# HP-WG Wall Bracket Mount Spackle Flange Installation Instructions

## Step 5 - Joining Luminaires

### A. Align Starter and Joiner/Ender Top View



**CAUTION**

**DO NOT** attempt to join luminaires together on the floor. Damage may result when lifted. Follow these instructions.

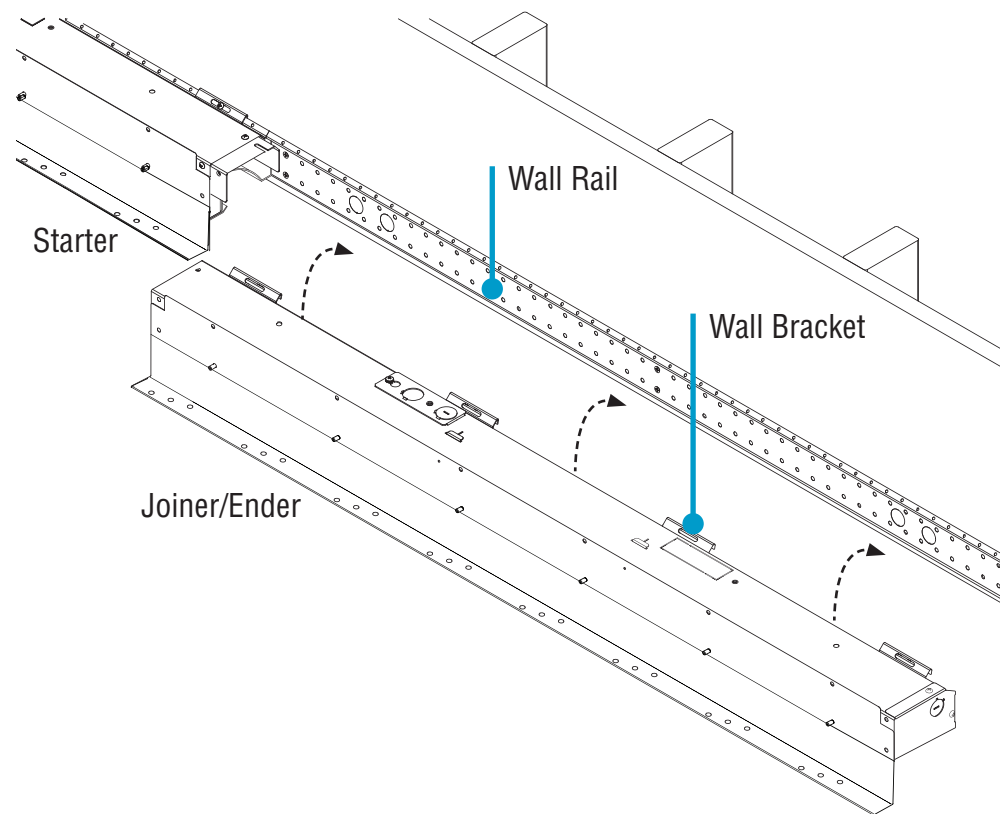

- Mount joiner/ender luminaire to wall rail by ensuring wall bracket grabs top of wall rail.
- Align end of starter luminaire to start of main wall rail.

### B. Plug-Together Wiring Top View

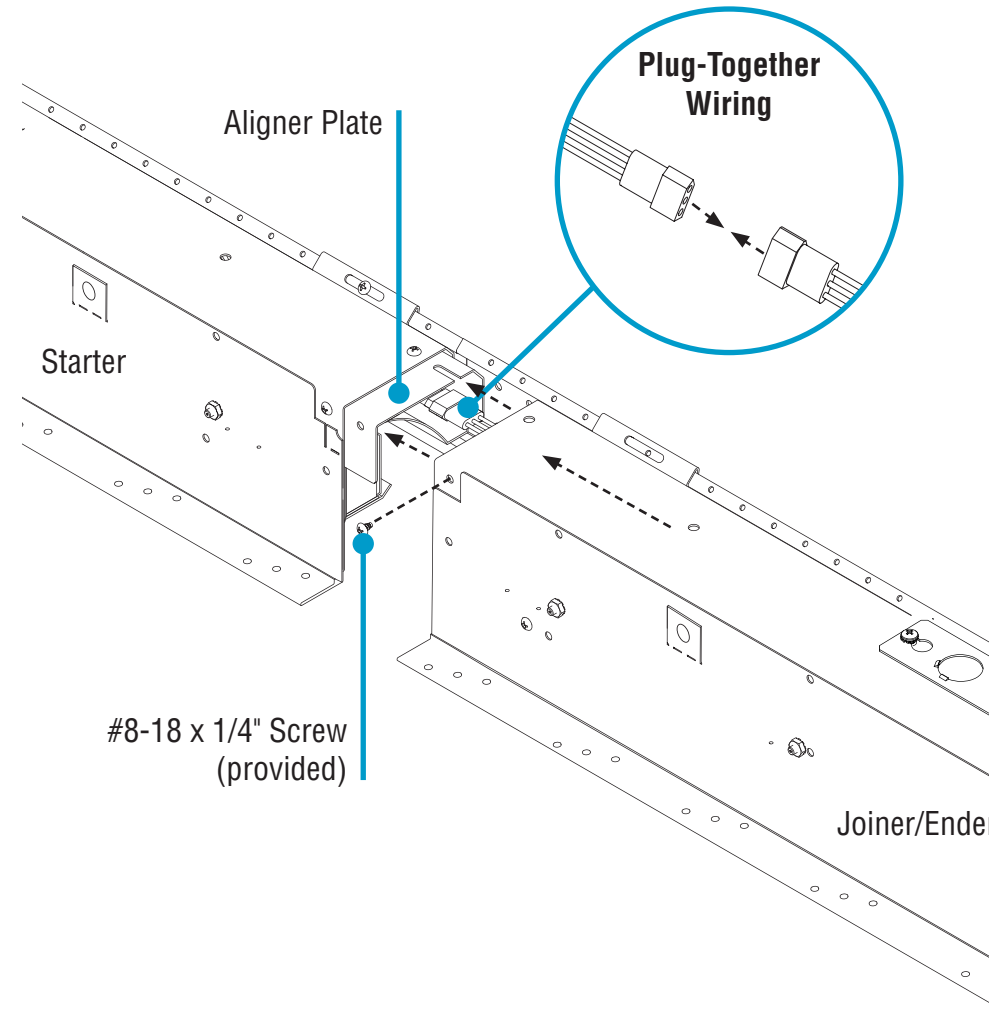

- Connect plug-together wiring.
- Slide joiner/ender luminaire over aligner plate on starter luminaire and align holes.
- Secure joiner/ender luminaire to aligner plate using #8-18 x 1/4" screws.

### C. Secure Joiner/Ender Top View

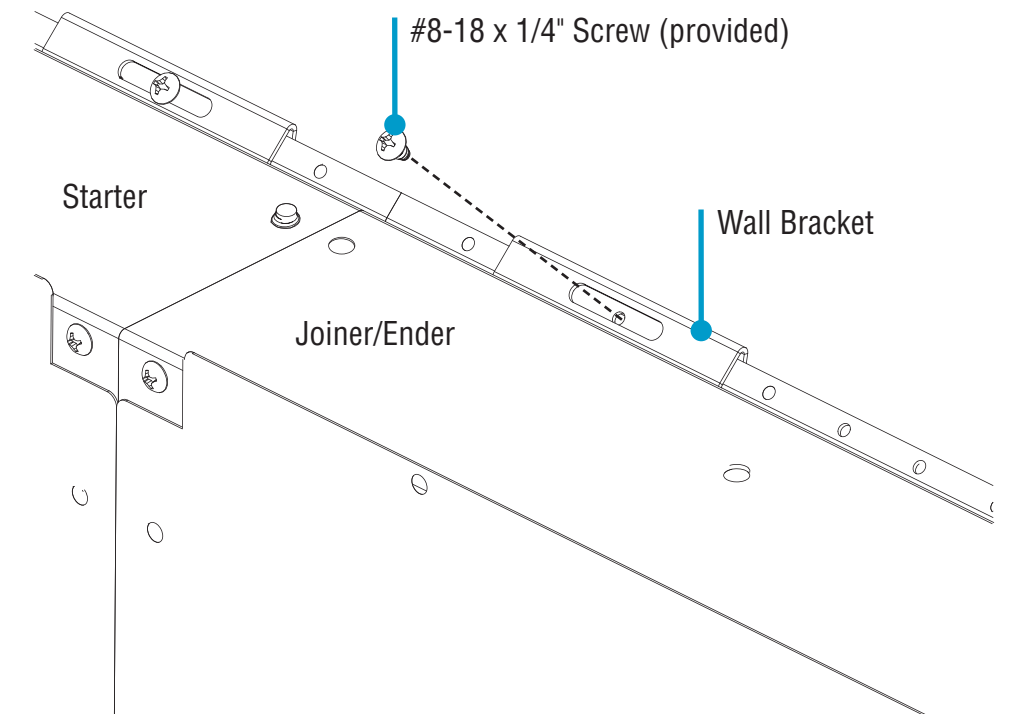

- Secure joiner/ender luminaire to wall rail with #8-18 x 1/4" screws through wall brackets.
- Repeat this step if you have a long run with additional luminaires on the same wall.

 #8-18 x 1/4" Screw (provided)



Simple Plug-Together Wiring

# HP-WG Wall Bracket Mount Spackle Flange Installation Instructions

## Step 6 - Closing Luminaires

### A. Structural Blocking Side View

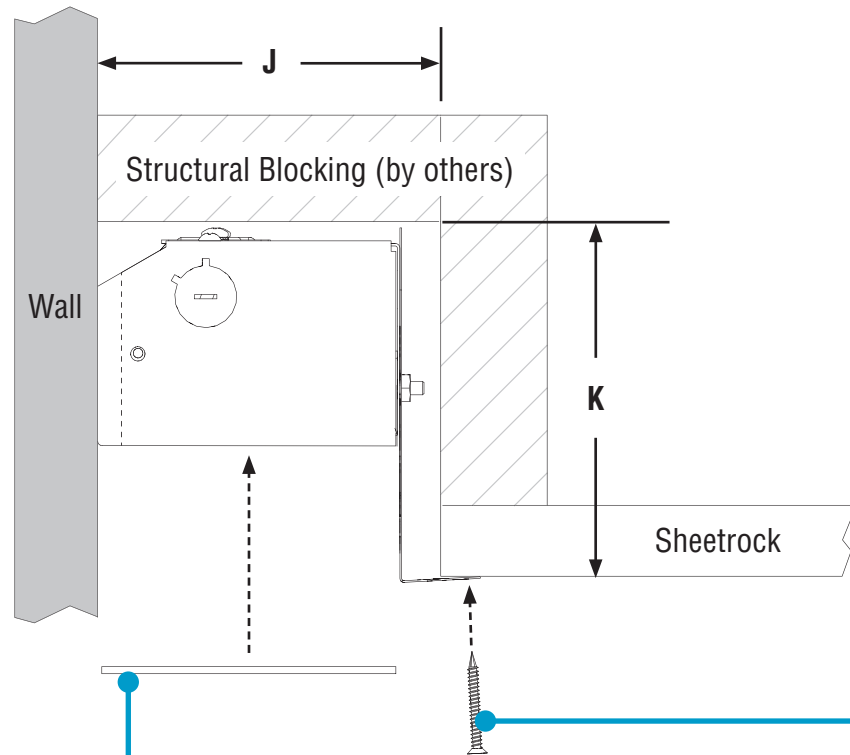

Mud Guard Cardboard Insert (provided)

Use additional appropriate hardware (by others) to secure luminaire to support blocking.

Luminaire Depth	J (in)	K (in)
2"	6-5/8	5-1/8
4"	6-5/8	7-1/8
6"	6-5/8	9-1/8

- Provide appropriate support blocking for proper drywall installation using the table above.
- **NOTE:** Make sure to leave ample space around wiring conduit.

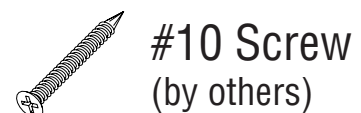

### B. Secure Spackle Flange Bottom-Up View

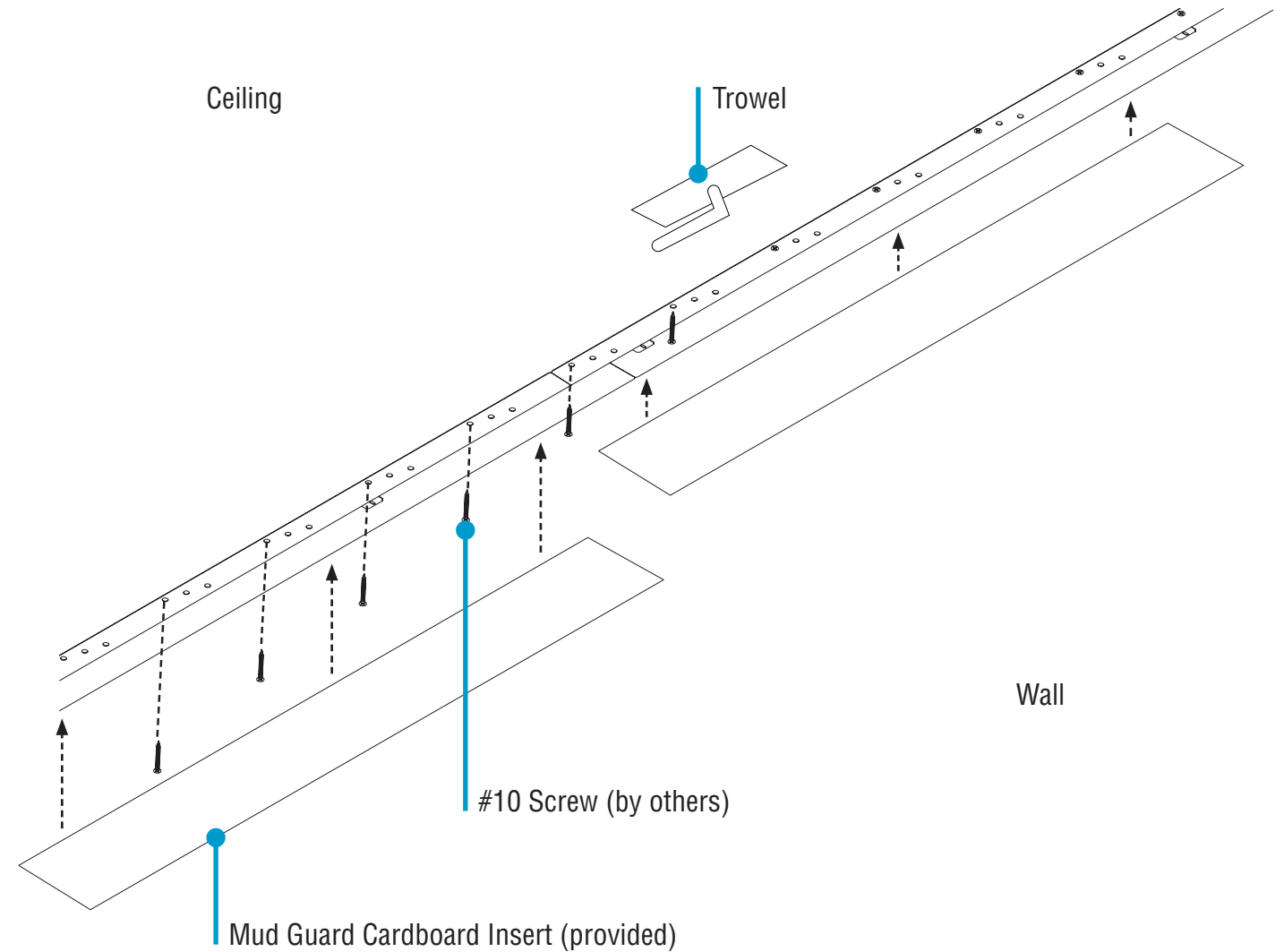

- Mount spackle flange to drywall ceiling using appropriate #10 screws.
- Install mud guard cardboard inserts to help prevent spackle and paint from getting into the luminaire.
- Spackle to cover the flange.
- Perform all spackling and painting to walls and ceiling before removing mud guards.

CONTINUED



# HP-WG Wall Bracket Mount Spackle Flange Installation Instructions

## Step 6 - Closing Luminaires

**C. Final Step - Install Cover Sleeve** Side View

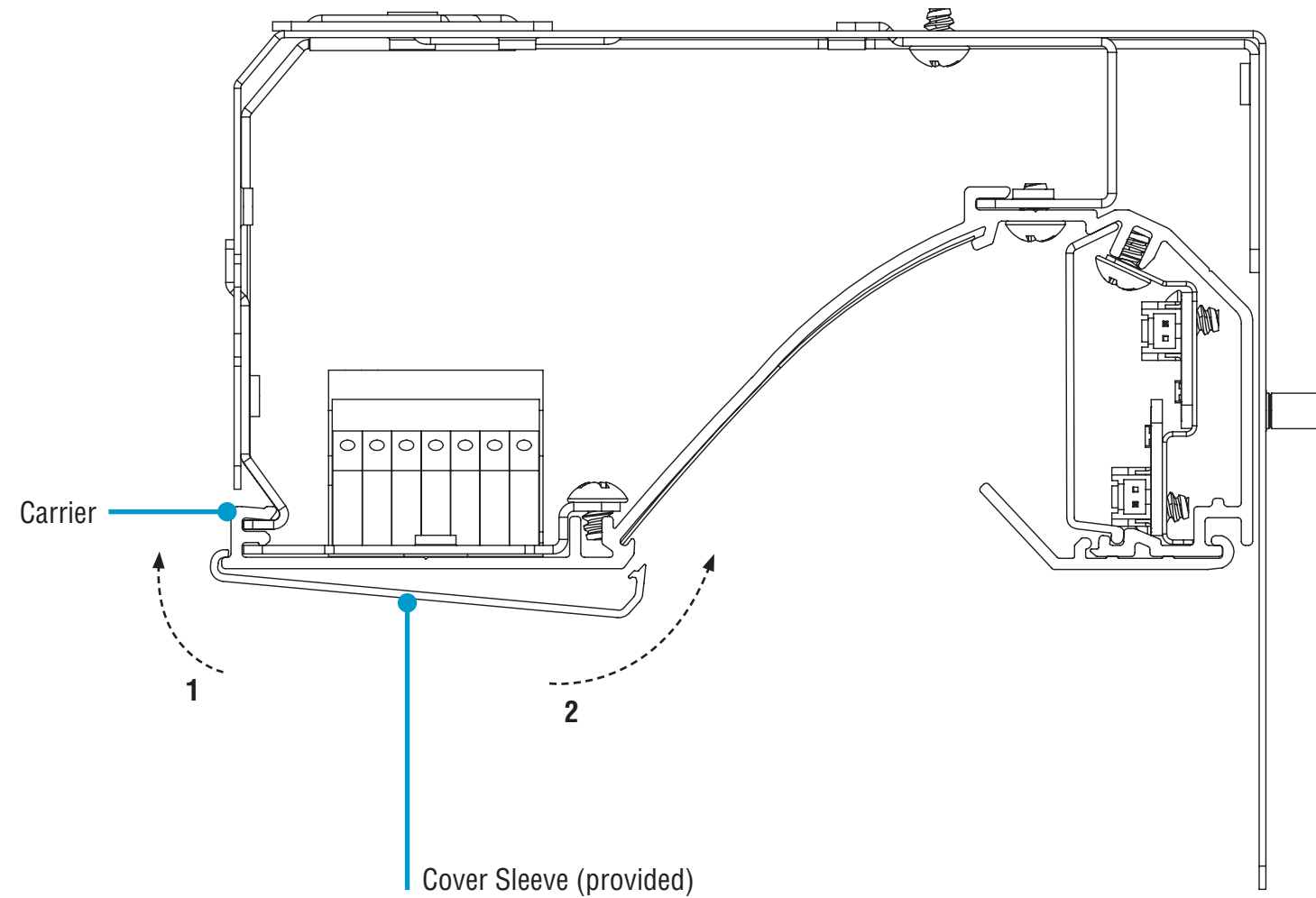

- 1. Hook back edge of cover sleeve over edge of carrier.
- 2. Snap front edge of cover sleeve in place along the whole length of the luminaire (about every 6").
- Once cover sleeve is in place, turn power on to luminaire.



**Cover Sleeve**  
(provided)