

Acoustic Baffle Unlit Installation Instructions

Overview

NOTES

- All power connections should be installed according to local/national codes by a Certified Electrician.
- This installation requires **proper support** as each luminaire is being installed.



HELPFUL
VIDEO



Full Installation
Video

Step 1
Mounting & Suspension
Page 2

Step 2
Identification & Preparation
Page 3

Step 3
Mounting Illuminated Unit to Structure
Pages 4

Step 3
Join Acoustic Baffle
Pages 5 & 6

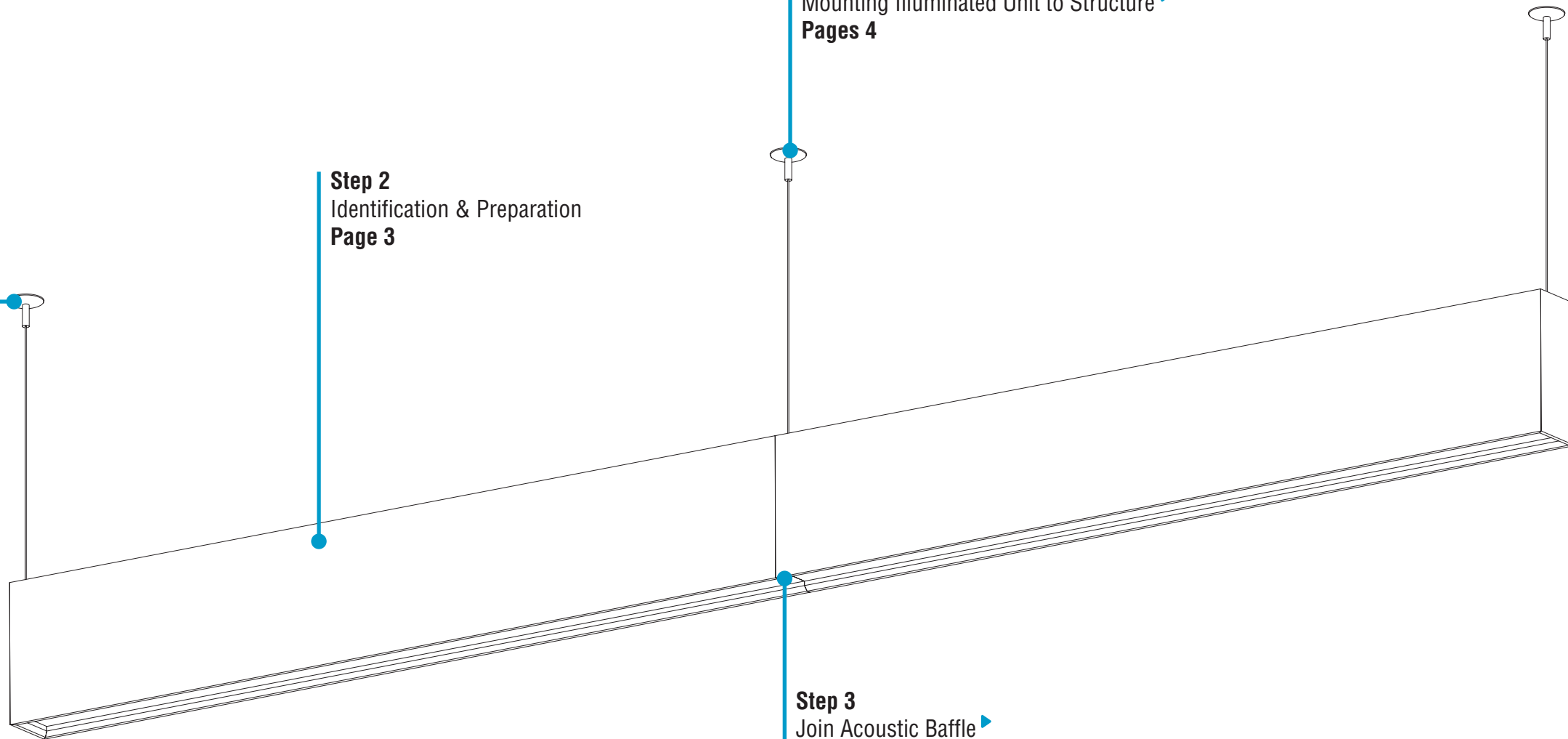

Acoustic Baffle Unlit Installation Instructions

Step 1 - Mounting & Suspension

Mounting Options

Option 1 T-Bar Mounting - Caddy Clips

- Install caddy clips at mounting point locations.
- All caddy clips are to be secured to structure, per local building codes.

Option 2 Drywall (C4) or other hard surfaces* - Anchor Bolts

- Install anchor bolts at mounting point locations.
- All anchor bolts are to be secured to structure, per local building codes.

* Other hard surfaces include: wood, sheet metal panels, steel beams, concrete, or masonry. Use hardware appropriate for each surface material type.

Suspension Locations

X = Suspension Dimensions

Refer to Record Drawings and building plans to determine exact mounting and suspension points.

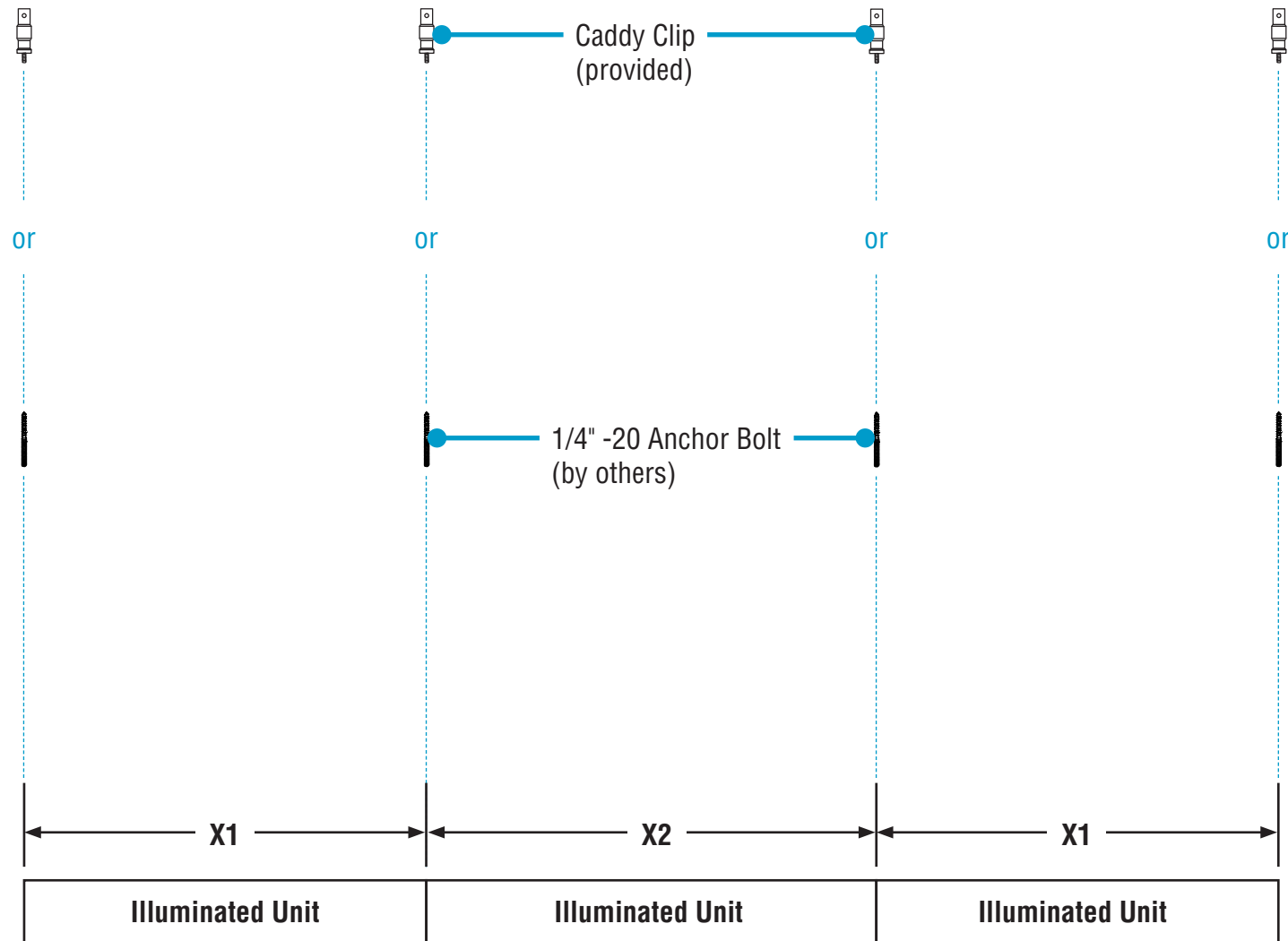

Mounting Option 1

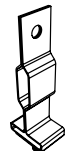

Caddy Clip
(provided)

Mounting Option 2



1/4\" -20 Anchor Bolt
(by others)

Acoustic Baffle Unlit Installation Instructions

Step 2 - Identification & Preparation

A. Identify Luminaires



Arrange luminaires in order according to ID# at their install locations.

CAUTION

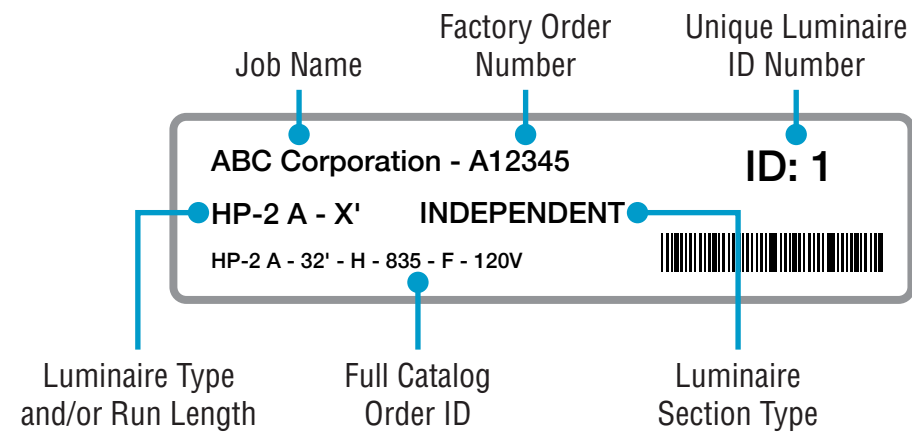

B. Prepare Acoustic Baffle Top-Down View

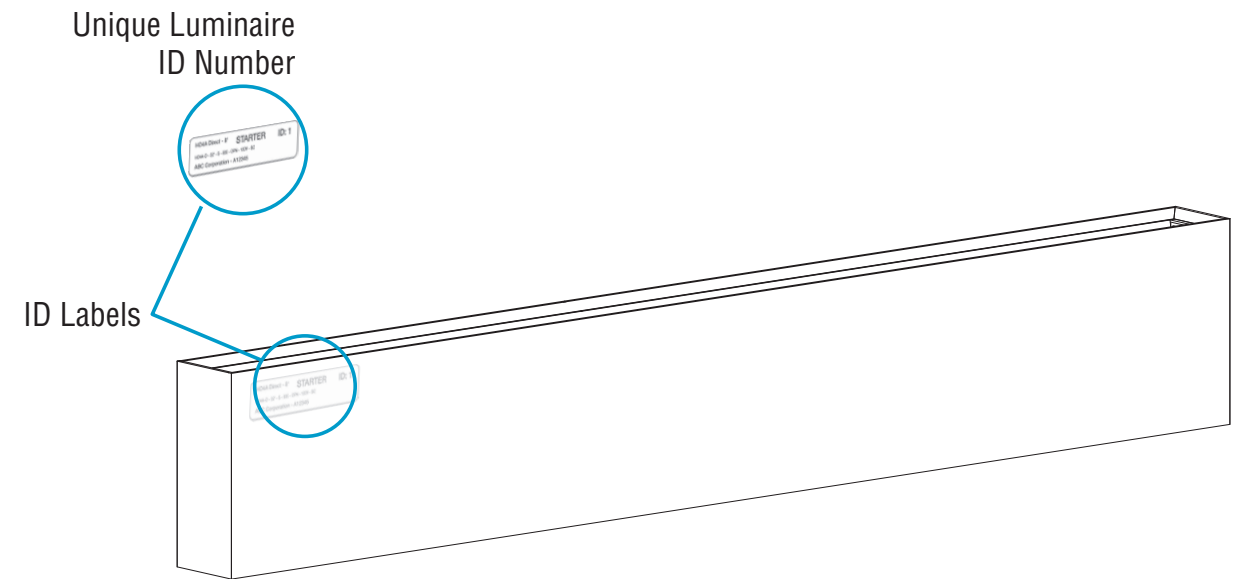

- Identify all Acoustic Baffle by their ID label that can be found on the box.
- **NOTE:** Exact location of labels in these areas may vary.
- Remove all Acoustic Baffle from their box.
- Refer to Record Drawings that can be found in the hardware kit.

Kitted Hardware

- Finelite has provided items listed here, with their Finelite part numbers. These items can be found in separate boxes shipped with the luminaire.
- Account for all parts and set aside until they are needed.
- All other hardware needed for this installation will be by others.

Mounting Option 1

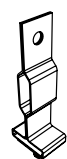

Caddy Clip

C1 Ceiling - Part# 94001
C2 Ceiling - Part# 94020
C3 Ceiling - Part# 94029
Mounting & Suspension
p. 2, Step 1

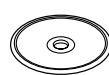

2" T-Bar Support Canopy

Part# 89193
Mounting Acoustic Baffle Unlit
p. 4, Step 3
p. 5, Step 4

Mounting Option 2



2" Drywall Support Canopy

Part# 94017
Mounting Acoustic Baffle Unlit
p. 4, Step 3
p. 5, Step 4



Gripper

Part# 68129
Mounting Acoustic Baffle Unlit
p. 4, Step 3
p. 5, Step 4

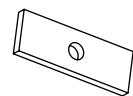

Safety Bar

Part# 93500
Mounting Acoustic Baffle Unlit
p. 4, Step 3

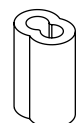

Safety Crimp

Part# 94514
Mounting Acoustic Baffle Unlit
p. 4, Step 3



Cable Bushing

Part# 94014

Aircraft Cable

50' - Part# 94515-12 (Std.)
100' - Part# 94515-14
150' - Part# 94515-18
Mounting Acoustic Baffle Unlit
p. 4, Step 3
p. 5, Step 4



Slip Ring w/ Set Screw

Part# 94015
Mounting Acoustic Baffle Unlit
p. 4, Step 3
p. 5, Step 4



1/4" Washer

Part# 92080
Mounting Acoustic Baffle Unlit
p. 4, Step 3
p. 5 & 6, Step 4



Screw

Part# 94126
Mounting Acoustic Baffle Unlit
p. 4, Step 3



Nut

Part# 94048
Join Acoustic Baffle
p. 5 & 6, Step 4

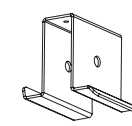

Joiner Support Bracket

Part# 29649
Join Acoustic Baffle
p. 5, Step 4

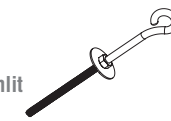

Joiner Bolt

Part# 92055
Join Acoustic Baffle
p. 5, Step 4

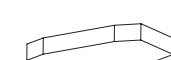

Felt Aligner Block

One included with each Acoustic Run Section (Not used for independents)
Join Acoustic Baffle
p. 5, Step 4

Acoustic Baffle Unlit Installation Instructions

Step 3 - Mounting Acoustic Baffle to Structure

Mount Acoustic Baffle Unit to Structure Bottom-Up View

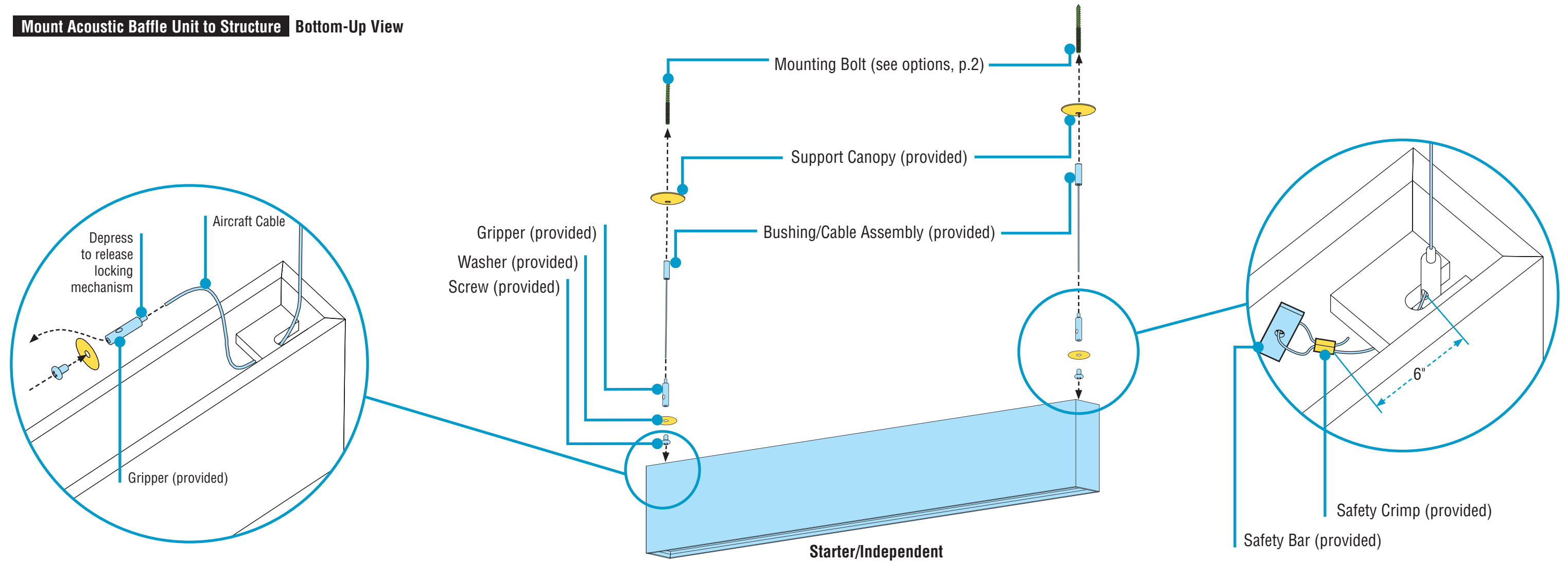

- Feed the Aircraft Cable through Gripper and add screw washer to bottom of Gripper.
- While properly supporting baffle, maneuver baffle to ceiling.
- Thread the bushing/cable assembly onto mounting bolts.
- Slide support canopy onto mounting bolt (anchor bolt or caddy clip bolt).
- **CRITICAL:** Level each baffle to desired height by depressing top of gripper to adjust cable length.
- **CRITICAL:** If installing an independent luminaire, perform all leveling.

- Estimate required length of cable and add 8"
- Loop cable through Safety Crimp and Safety Bar, then back through Safety Crimp.
- Crimp, then cut excess cable. Remaining 6" of cable.

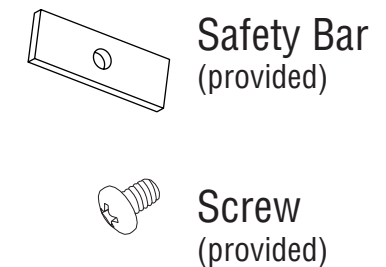
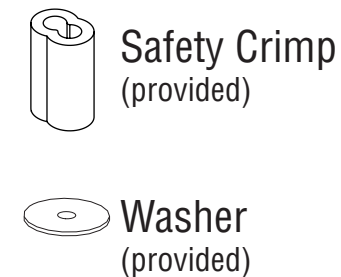
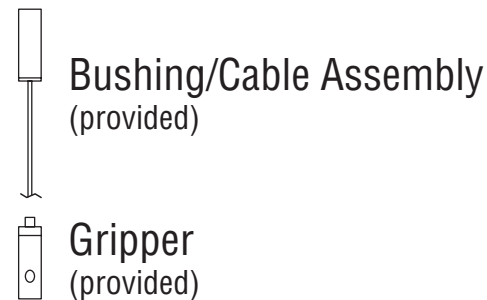
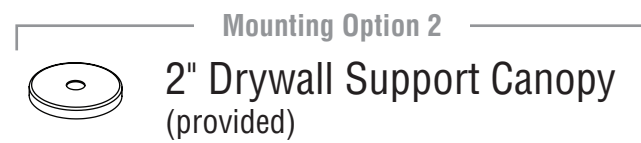
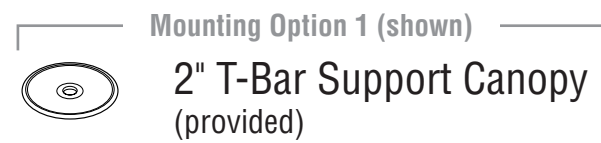

Aircraft Cable Installation

Acoustic Baffle Unlit Installation Instructions

Step 4 - Join Acoustic Baffle

A. Assemble Joiner Support Bracket

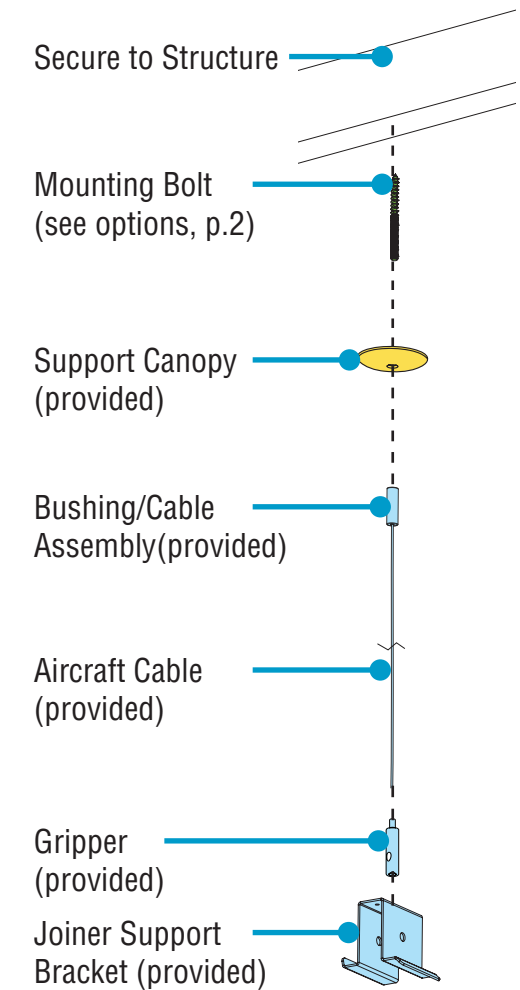

- Feed the Aircraft Cable through Gripper and add screw washer to bottom of Gripper.
- Install Gripper to Joiner Support Bracket
- Secure Support Canopy and Bushing/Cable to structure.

B. Secure Join Acoustic Baffle to Structure Bottom-Up View

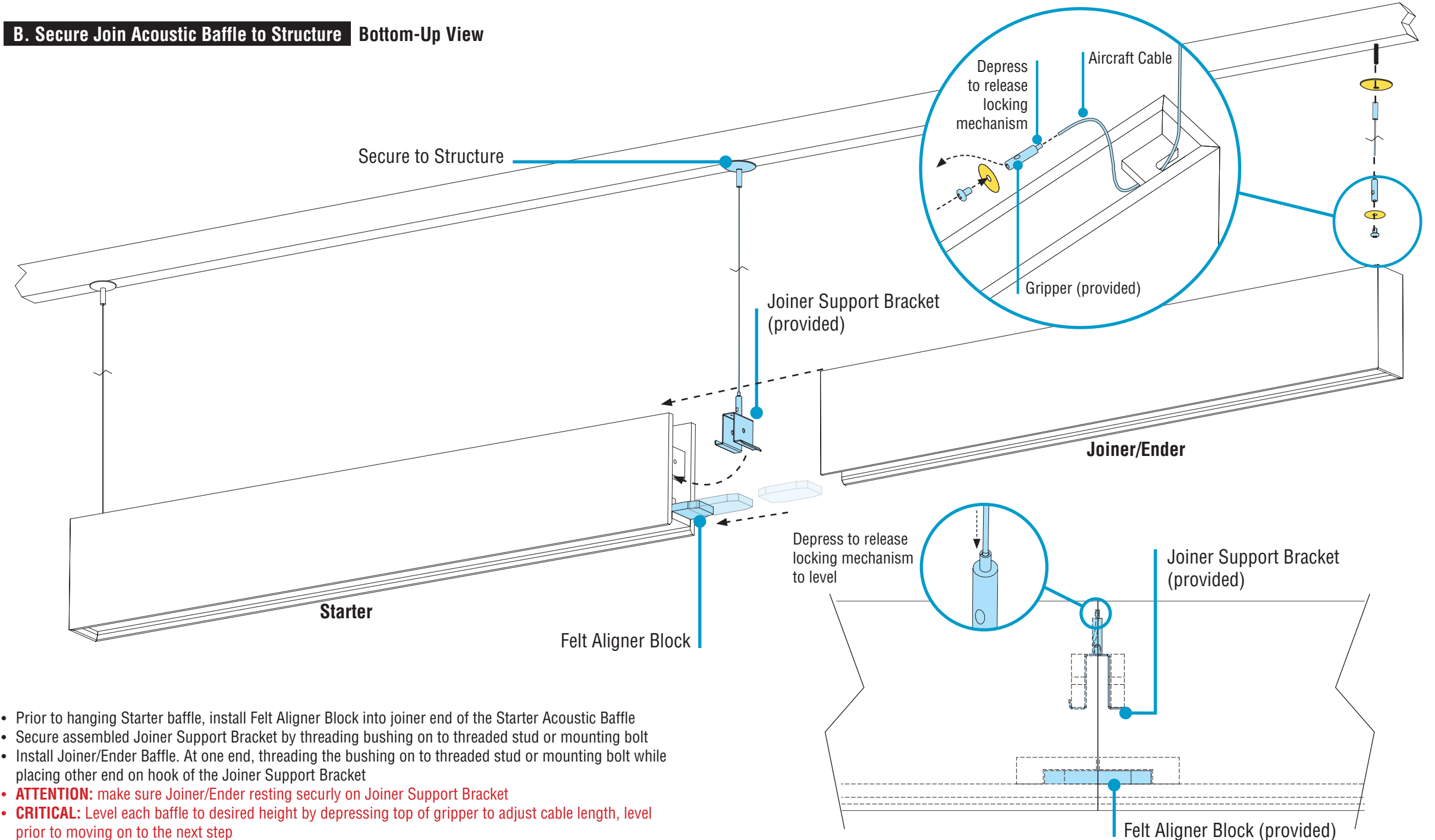

- Prior to hanging Starter baffle, install Felt Aligner Block into joiner end of the Starter Acoustic Baffle
- Secure assembled Joiner Support Bracket by threading bushing on to threaded stud or mounting bolt
- Install Joiner/Ender Baffle. At one end, threading the bushing on to threaded stud or mounting bolt while placing other end on hook of the Joiner Support Bracket
- **ATTENTION:** make sure Joiner/Ender resting securely on Joiner Support Bracket
- **CRITICAL:** Level each baffle to desired height by depressing top of gripper to adjust cable length, level prior to moving on to the next step

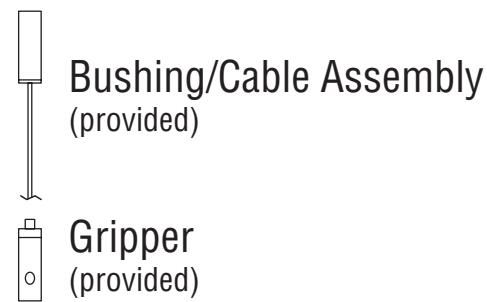
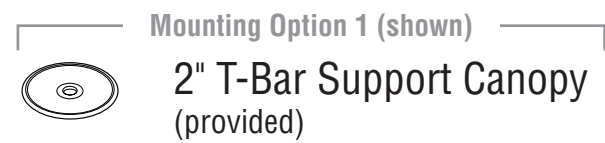

Joint Installation

Acoustic Baffle Unlit Installation Instructions

Step 4 - Join Acoustic Baffle

C. Secure Join Acoustic Baffle Top View

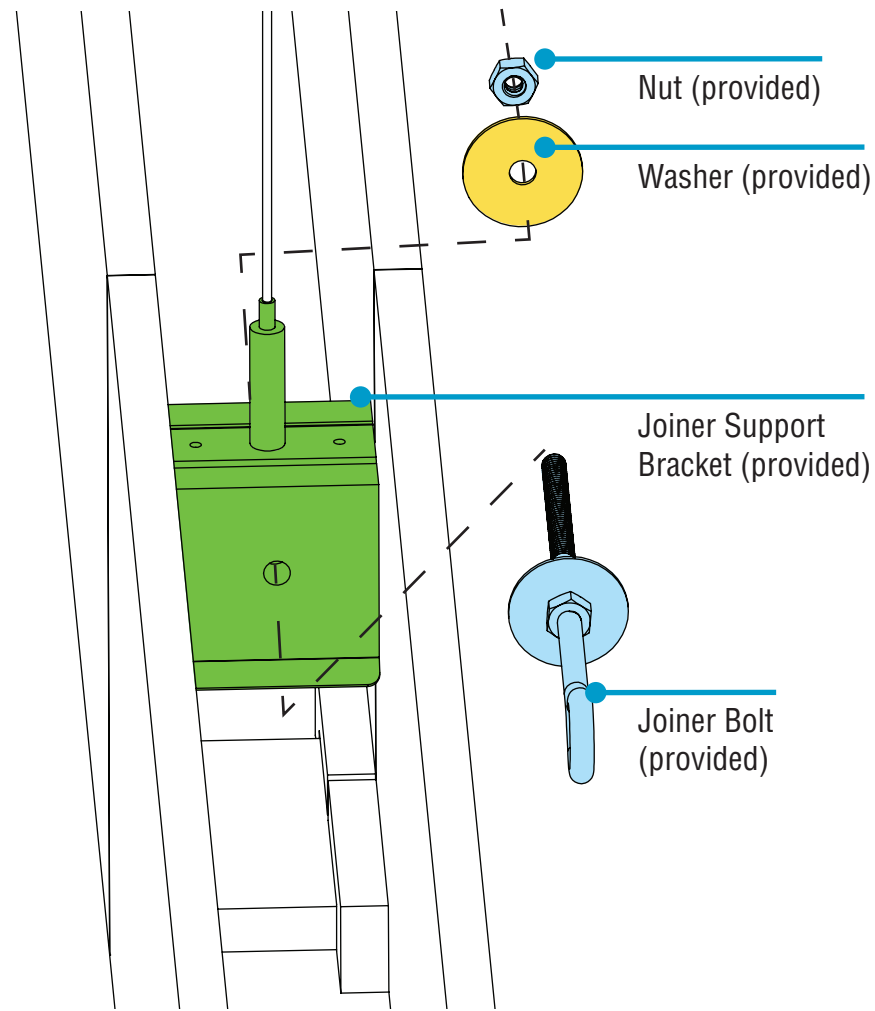

- Insert the Joiner Bolt through Joiner Support Bracket and secure with Washer & Nut
- **CRITICAL: DO NOT** over tighten.

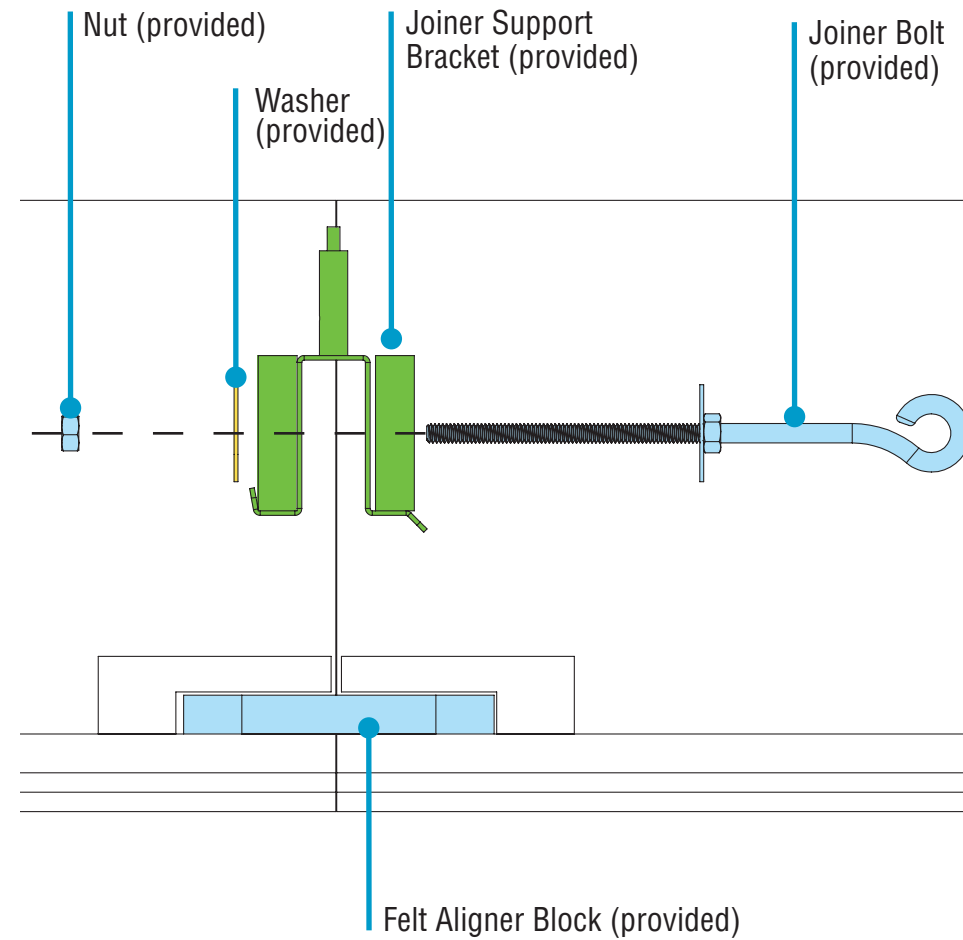
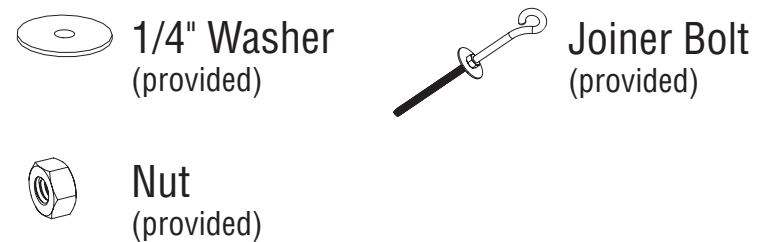

Finish

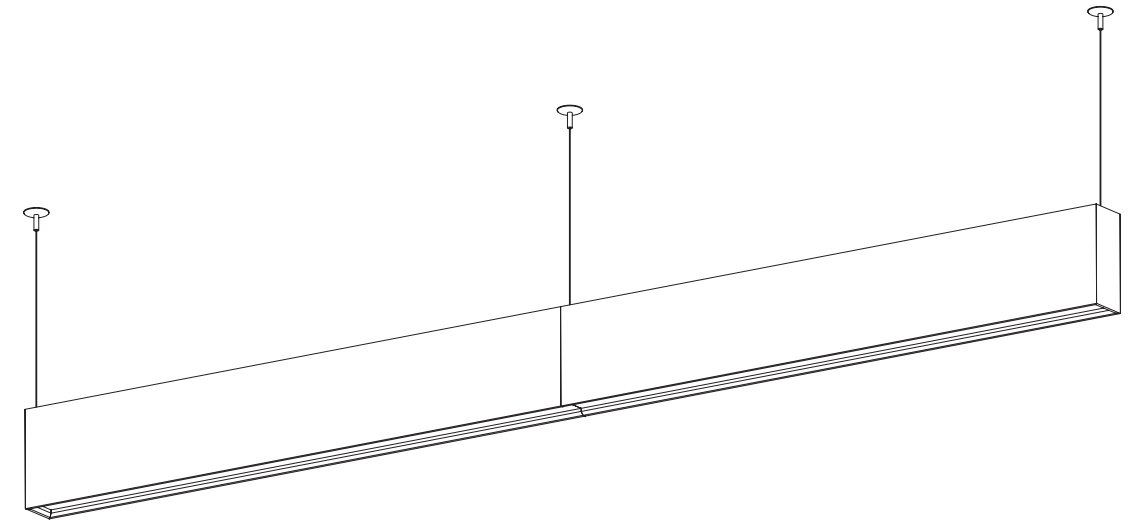

Secure Joint