

# Series 19 Installation Instructions

## Overview

### NOTES

- All power connections should be installed according to local/national codes by a Certified Electrician.
- This installation requires **proper support** as each luminaire is being installed.
- **DO NOT attempt to join luminaires together on the floor.** Damage may result when lifted.



HELPFUL  
VIDEOS



Install  
Aircraft  
Cable



0-10V  
Dimming



Joining  
Luminaires

**Step 1**  
Mounting & Suspension  
**Page 2**

**Step 2**  
Identification & Preparation  
**Page 3**

**Step 3**  
Mounting Starter  
to Structure  
**Page 4**

**Step 4**  
Joining Luminaires  
**Page 5**

**Step 5**  
Securing Luminaire Joints  
**Page 6**

**Step 6**  
Closing Luminaires  
**Page 7**

# Series 19 Installation Instructions

## Step 1 - Mounting & Suspension

### Mounting Options

#### Option 1 T-Bar Mounting - GridBox™ and Caddy Clips

- Install GridBox™ and electrical conduit at feed locations.
- Install caddy clips at mounting point locations.
- All caddy clips are to be secured to structure, per local building codes.

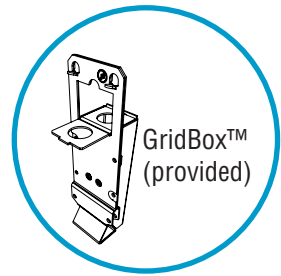

or

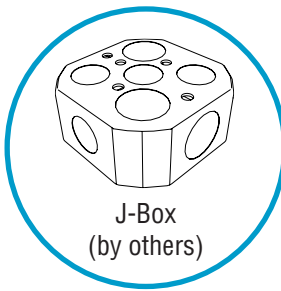

#### Option 2 Drywall (C4) or other hard surfaces\* - J-Box and Anchor Bolts

- Install J-Box and electrical conduit at feed locations.
- Install anchor bolts at mounting point locations.
- All anchor bolts are to be secured to structure, per local building codes.

\* Other hard surfaces include: wood, sheet metal panels, steel beams, concrete, or masonry. Use hardware appropriate for each surface material type.

### Suspension Locations

X = Suspension Dimensions

Refer to Record Drawings and building plans to determine exact mounting, suspension points, and power feed locations.

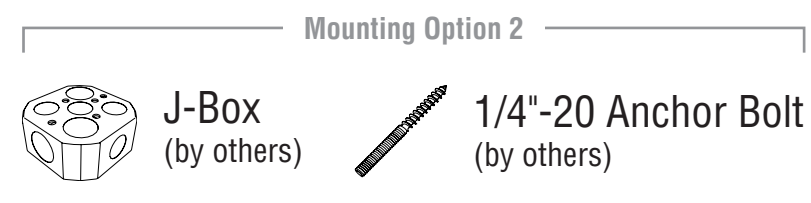
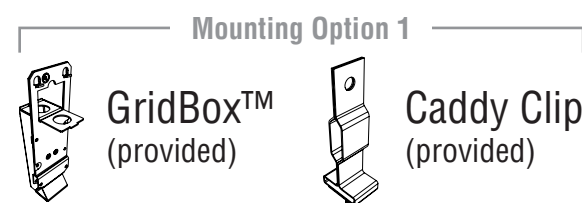
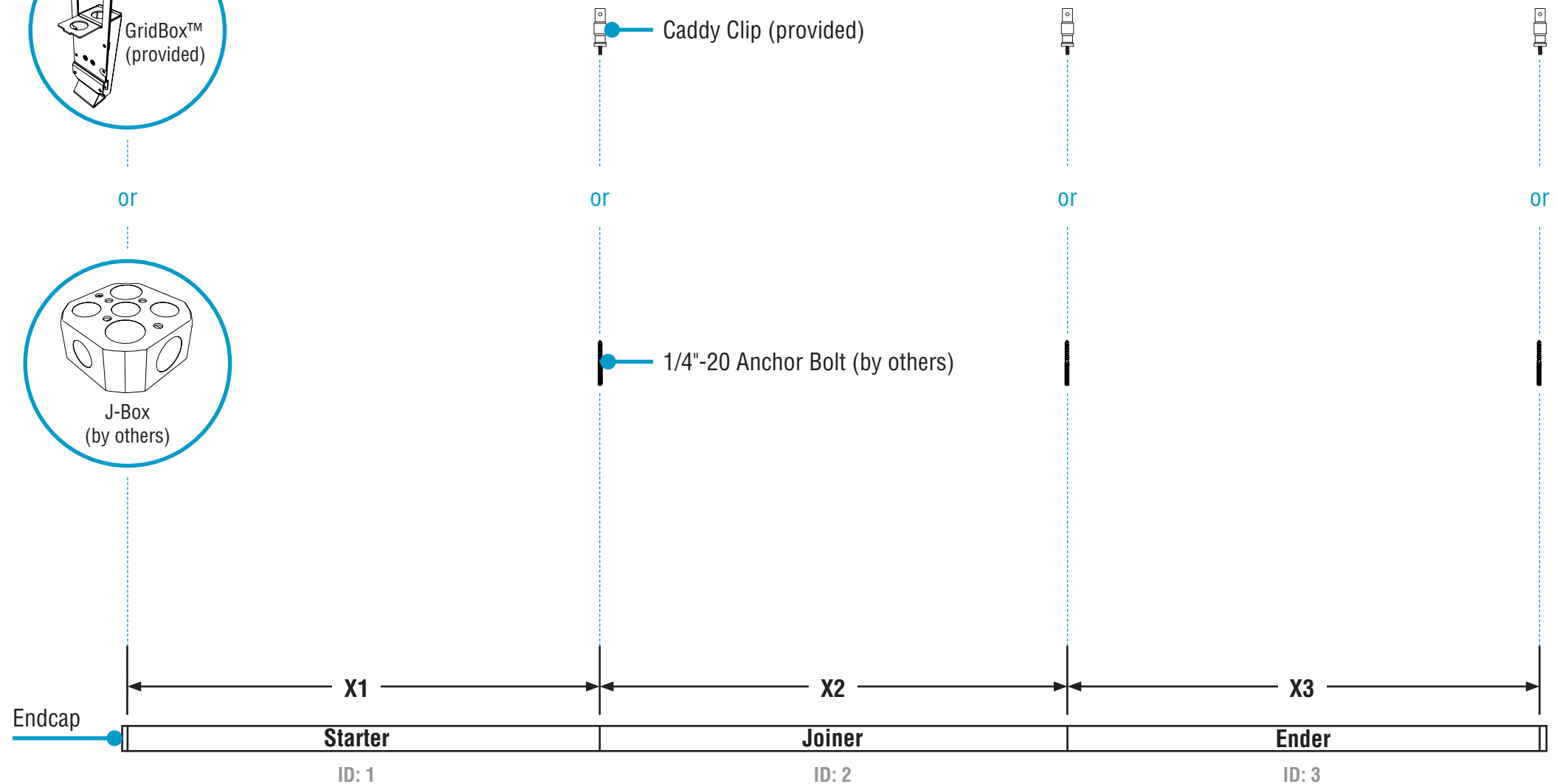

# Series 19 Installation Instructions

## Step 2 - Identification & Preparation

### A. Identify Luminaires



Arrange luminaires in order according to ID# at their install locations.

**CAUTION**

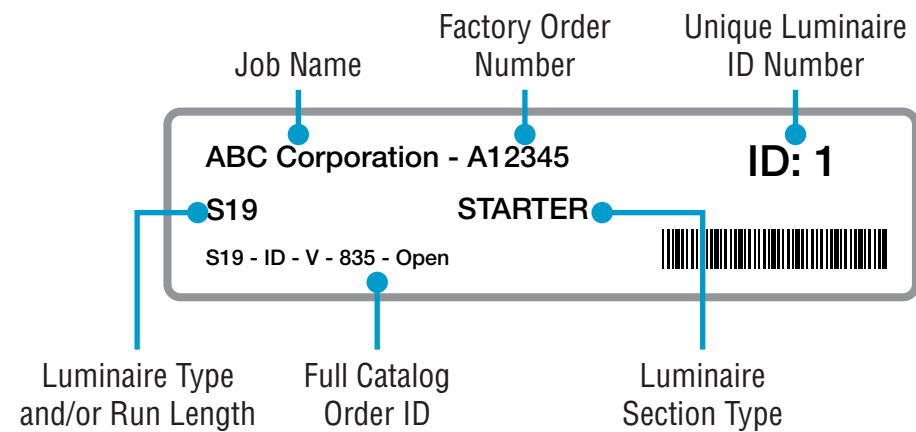

- Identify all luminaires by their ID label that can be found on the box, the protective bag, and inside the luminaire.
- **NOTE:** Exact location of labels in these areas may vary.
- Carefully remove all luminaires from their box.
- Refer to Record Drawings that can be found in the hardware kit.

### B. Preparation Top-Down View

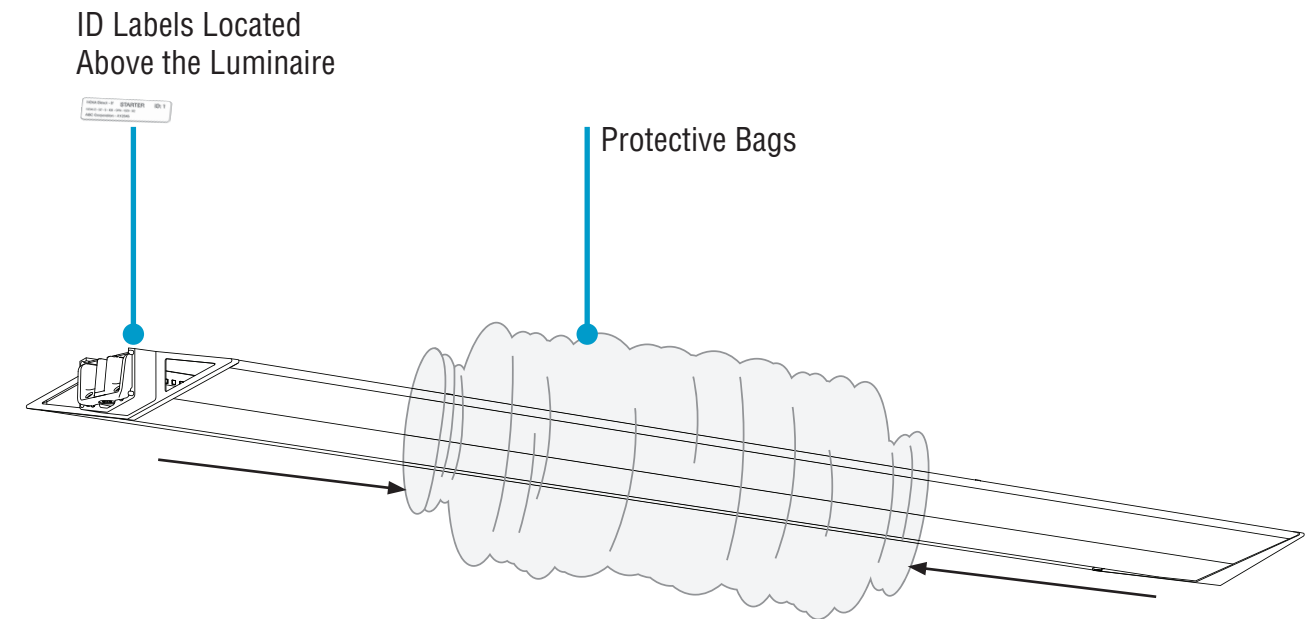





- Push protective bag(s) toward to center of the luminaire to expose endcaps from both ends. Keep protective bag(s) on until after site cleanup.

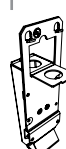

### Kitted Hardware

- Finelite has provided items listed here, with their Finelite part numbers. These items can be found in separate boxes shipped with the luminaire.
- Account for all parts and set aside until they are needed.
- All other hardware needed for this installation will be by others.

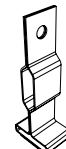
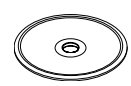
#### Mounting Option 1

 <b>GridBox™</b> Part# 89159	 <b>3-1/2" Canopy</b> Part# 89191
 <b>Dual GridBox™</b> Part# 89199 Mounting & Suspension p. 4, Step 3	 <b>3-1/2" Dual Feed Canopy</b> Part# 89192 Mounting Starter to Structure p. 4, Step 3 Joining Luminaires p. 5, Step 4
 <b>Caddy Clip</b> C1 Ceiling - Part# 94001 C2 Ceiling - Part# 94020 C3 Ceiling - Part# 94029 Mounting & Suspension p. 4, Step 3	 <b>3-1/2" T-Bar Support Canopy</b> Part# 89193 Mounting Starter to Structure p. 4, Step 3 Joining Luminaires p. 5, Step 4

#### Mounting Option 2

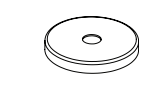
 <b>5" Canopy</b> Part# 94085	 <b>5" Dual Feed Canopy</b> Part# 94145 Mounting Starter to Structure p. 4, Step 3 Joining Luminaires p. 5, Step 4
 <b>2" Drywall Support Canopy</b> Part# 94017 Mounting Starter to Structure p. 4, Step 3 Joining Luminaires p. 5, Step 4	

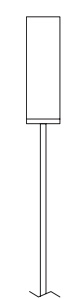

**Cable Bushing**  
Part# 94014

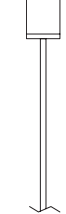

**Aircraft Cable**  
50" - Part# 94515-12 (Std.)  
100" - Part# 94515-14  
150" - Part# 94515-18  
Mounting Starter to Structure  
p. 4, Step 3  
Joining Luminaires  
p. 5, Step 4



**Slip Ring w/ Set Screw**  
Part# 94015  
Mounting Starter to Structure  
p. 4, Step 3  
Joining Luminaires  
p. 5, Step 4

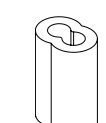

**Safety Crimp**  
Part# 94514  
Mounting Starter to Structure  
p. 4, Step 3



**#8-18 x 5/16" Screw**  
Part# 94059  
Mounting Starter to Structure  
p. 4, Step 3  
Joining Luminaires  
p. 5, Step 4



**#10-32 x 3/4" Screw**  
Part# 34170  
Securing Luminaires Joints  
p. 5, Step 4

# Series 19 Installation Instructions

## Step 3 - Mounting Starter to Structure

### A. Remove Access Plates Top-Down View

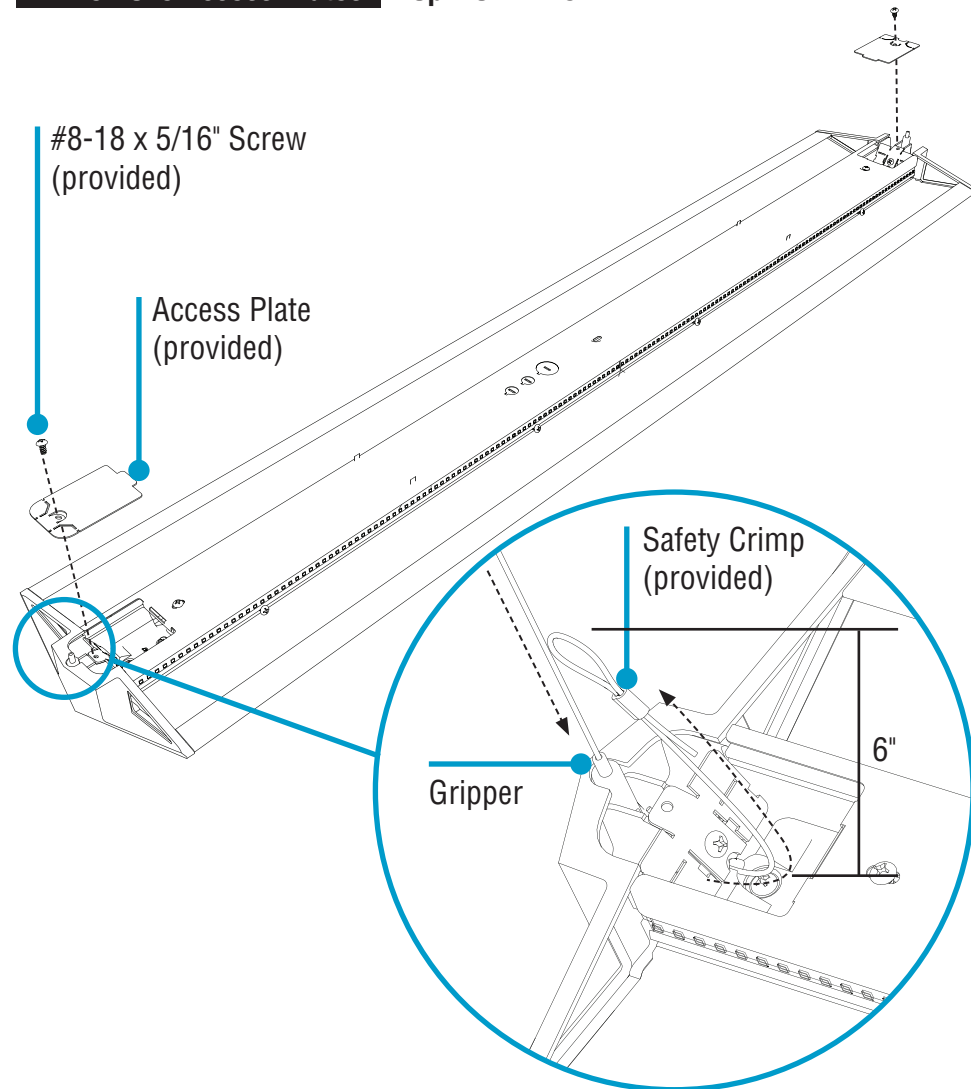

- **NOTE:** Keep luminaire on the ground while removing access plate and treading the cable into the gripper.
- Remove #8-18 x 5/16" screws to release access plate.
- Insert cable into gripper to desired suspension length, while leaving 6" of addition length for leveling.
- Loop additional cable through safety crimp then back through safety crimp.
- Crimp, then cut excess cable.
- Tuck safety loop inside luminaire.

### B. Mount Starter to Structure Bottom-Up View

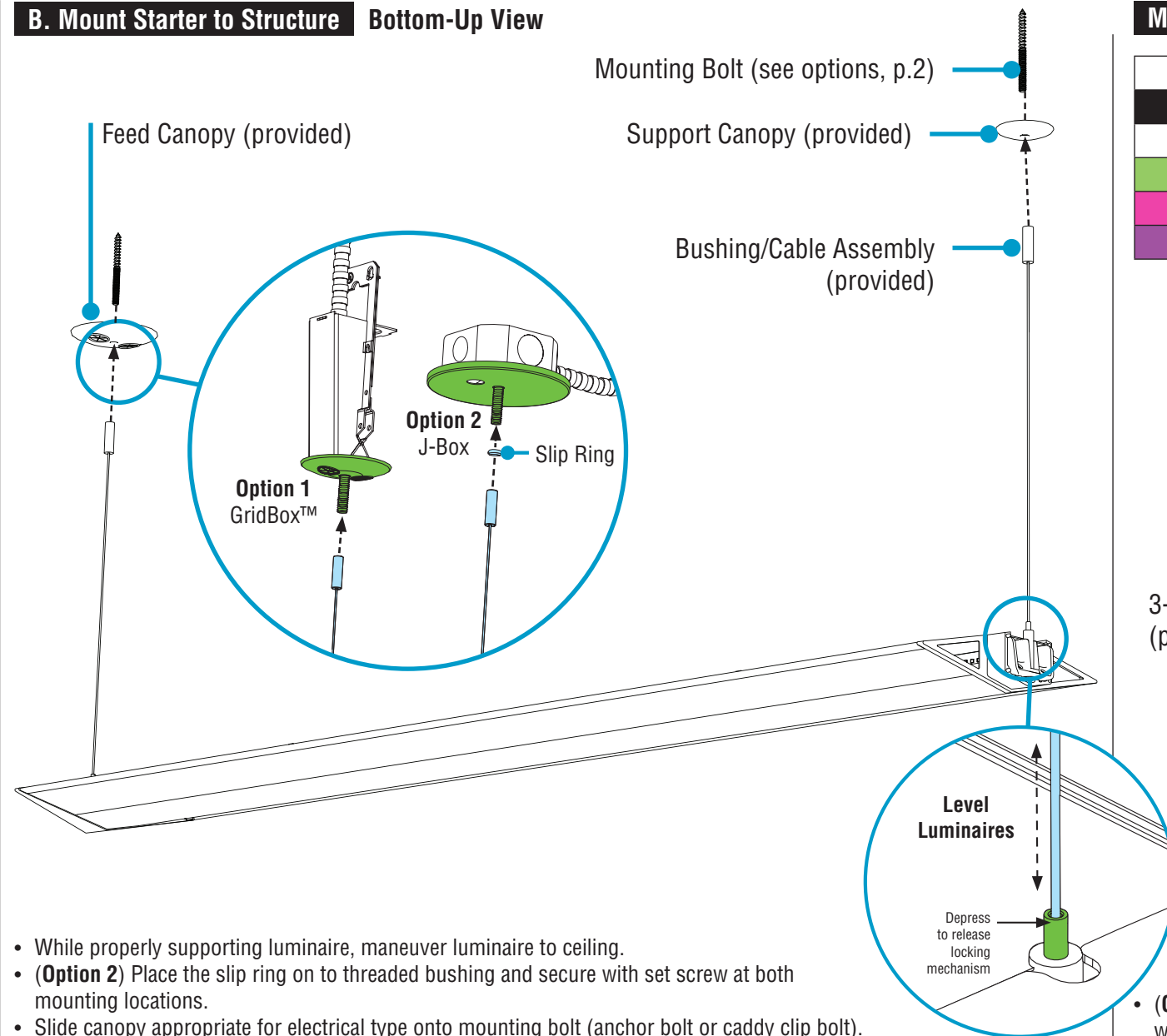

- While properly supporting luminaire, maneuver luminaire to ceiling.
- **(Option 2)** Place the slip ring on to threaded bushing and secure with set screw at both mounting locations.
- Slide canopy appropriate for electrical type onto mounting bolt (anchor bolt or caddy clip bolt).
- Thread the bushing/cable assembly onto mounting bolts.
- **NOTE:** Adjust canopy and slip ring snug to ceiling.
- Level luminaire to desired height by depressing top of gripper to adjust cable length.
- Feed the aircraft cable through and lead into the feed hole.

### Make Electrical Connections Bottom-Up View

WIRING LEGEND		
Black	Hot	Line Voltage
White	Neutral	Line Voltage
Green	Ground	
Pink	Dimming	0-10V DC
Purple	Dimming	0-10V DC

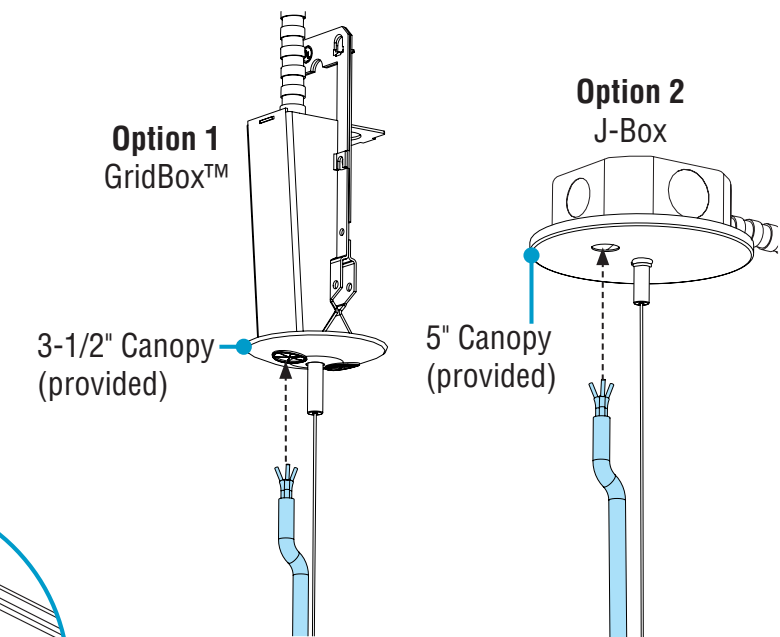

- **(Option 1)** Feed power cord through 3-1/2" canopy and connect wires inside GridBox™.
- **(Option 2)** Feed power cord through 5" canopy and connect wires inside J-Box.
- **CRITICAL:** If installing an independent luminaire, perform all leveling. **PROCEED TO STEP 6.**

#8-18 x 5/16" Screws (provided)

Mounting Option 1 (shown)  
3-1/2" Canopy (provided)

2" T-Bar Support Canopy (provided)

Mounting Option 2  
5" Canopy (provided)

2" Drywall Support Canopy (provided)

Slip Ring w/ Set Screw (provided)

Bushing/Cable Assembly (provided)



Install Aircraft Cable  
0-10V Dimming

# Series 19 Installation Instructions

## Step 4 - Joining Luminaires

### A. Mount Joiner/Ender to Structure Bottom-Up View



**CAUTION**

**DO NOT** attempt to join luminaires together on the floor. Damage may result when lifted. Follow these instructions.

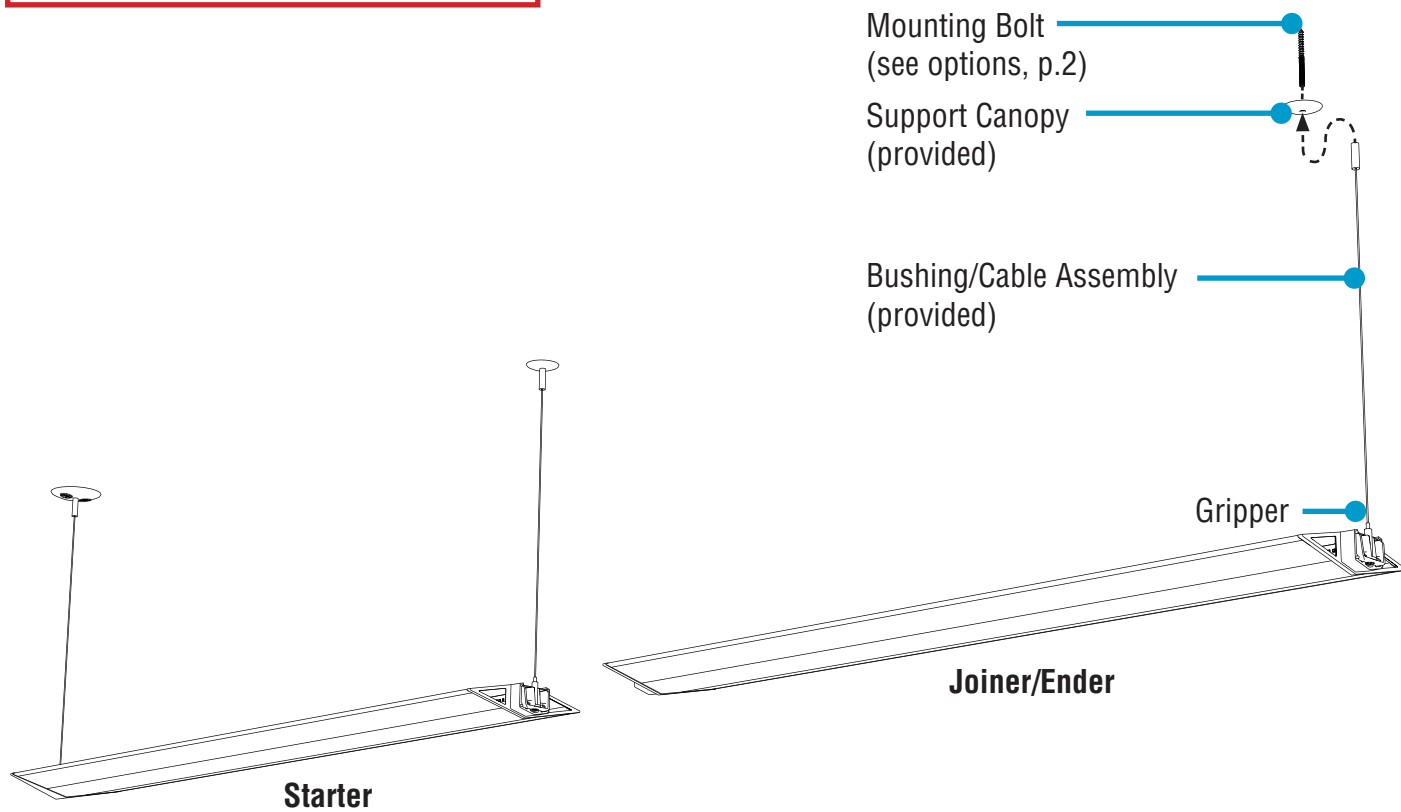

- Repeat Step 3A at non-joining end of luminaire
- While properly supporting luminaire, maneuver luminaire to ceiling.
- Slide canopy appropriate for electrical type onto mounting bolt (anchor bolt or caddy clip bolt).
- Thread the bushing/cable assembly onto mounting bolt.

### B. Join Luminaires Top-Down View



**CAUTION**

Once luminaires are aligned together, **joiner luminaire is not yet secure.** Ensure it does not slide off as it rests on the starter luminaire.

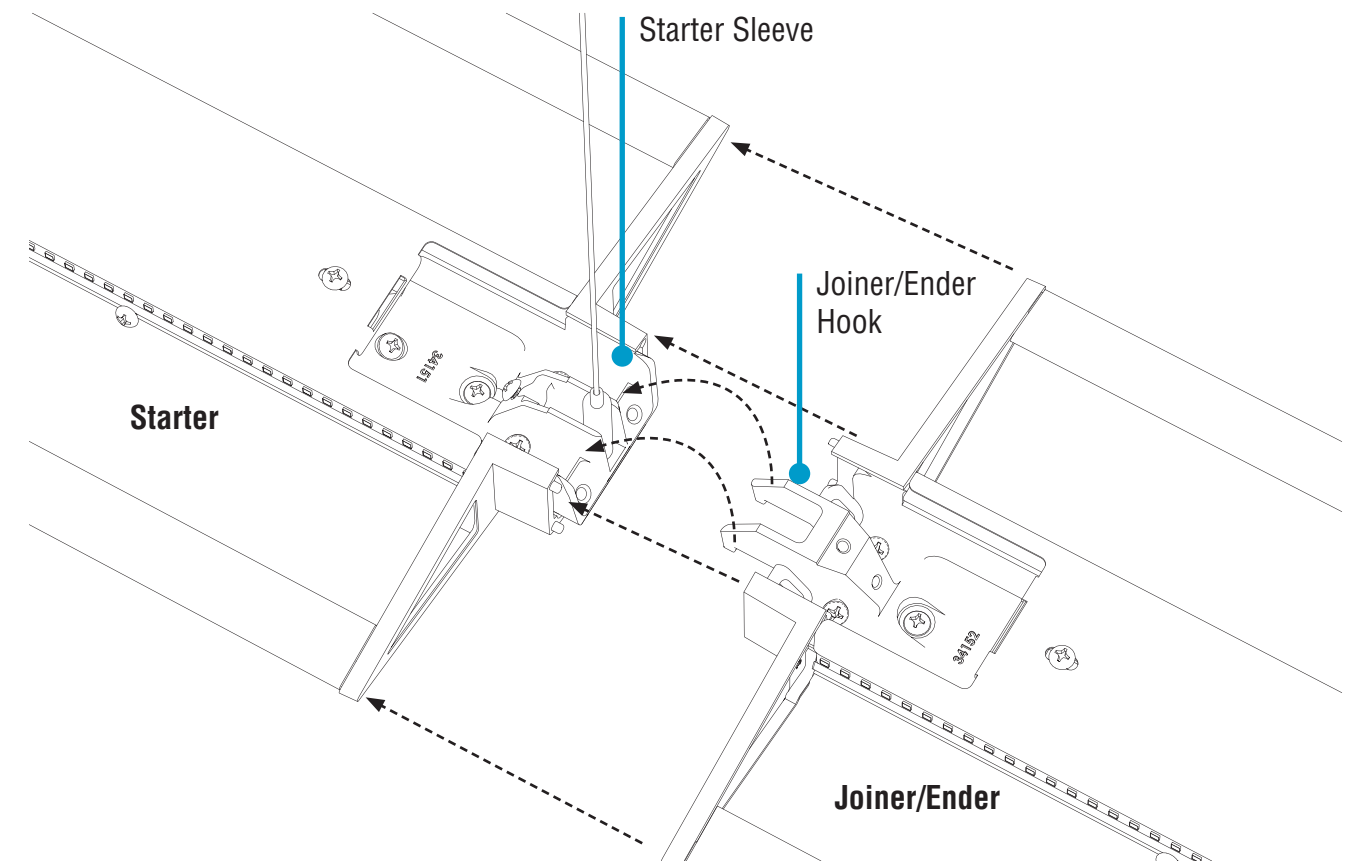

- Align joiner with starter sleeves on starter and joiner/ender hook.
- If necessary, **lift** both luminaires, then slide together.

#### Mounting Option 1 (shown)



3-1/2" Canopy (provided)

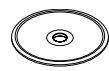

2" T-Bar Support Canopy (provided)

#### Mounting Option 2

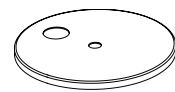

5" Canopy (provided)

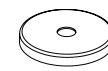

2" Drywall Support Canopy (provided)



Slip Ring w/ Set Screw (provided)



Bushing/Cable Assembly (provided)



Joining Luminaires

# Series 19 Installation Instructions

## Step 5 - Securing Luminaire Joints

### A. Secure Joint with Screw Top-Down View

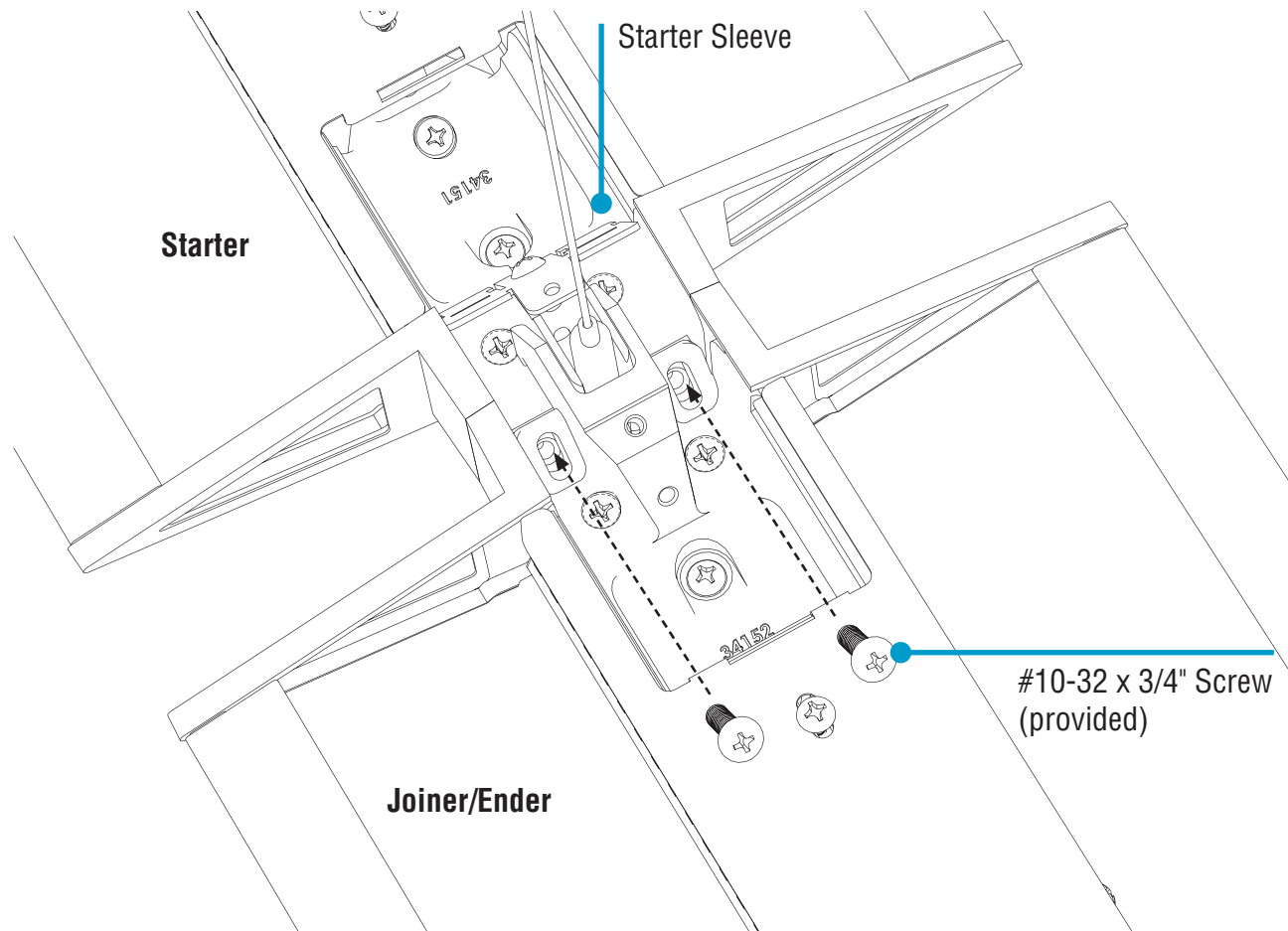

- Before joining, ensure the joining ends of luminaires meet flush and square.
- Secure joint by threading (**but not yet tightening**) the screws into the starter sleeves.
- Level each luminaire to desired height by depressing top of grippers to adjust cable lengths.
- **NOTE:** Ensure luminaires are level and meet flush and square before fully tightening the screws.



#10-32 x 3/4"  
(provided)

<sup>1</sup> Screwdriver with 6" bit required.

### B. Plug-Together Wiring Top-Down View

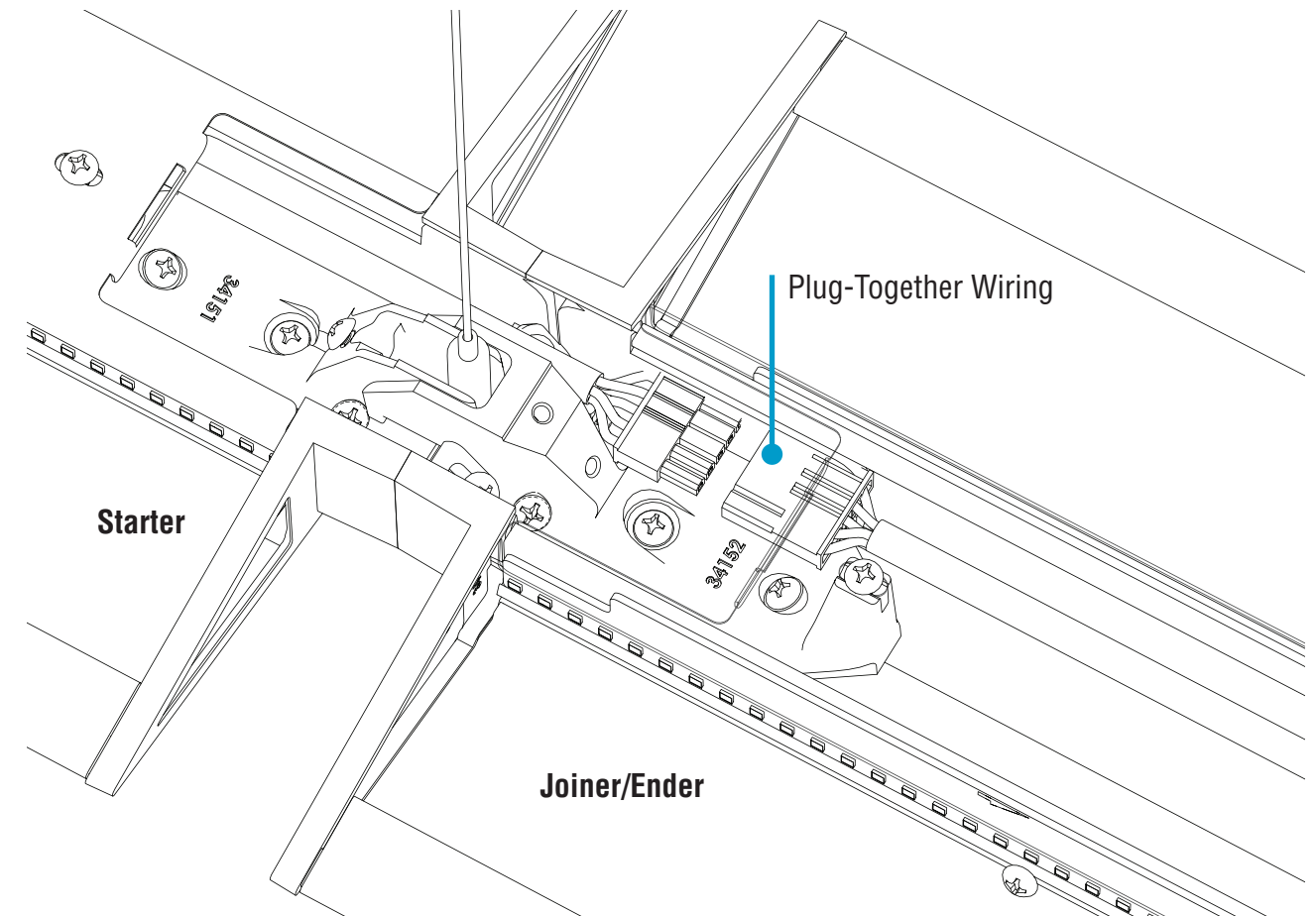

- Connect plug-together wiring.



Joining  
Luminaires

# Series 19 Installation Instructions

## Step 6 - Closing Luminaires

**Install Access Plate** Bottom-Up View

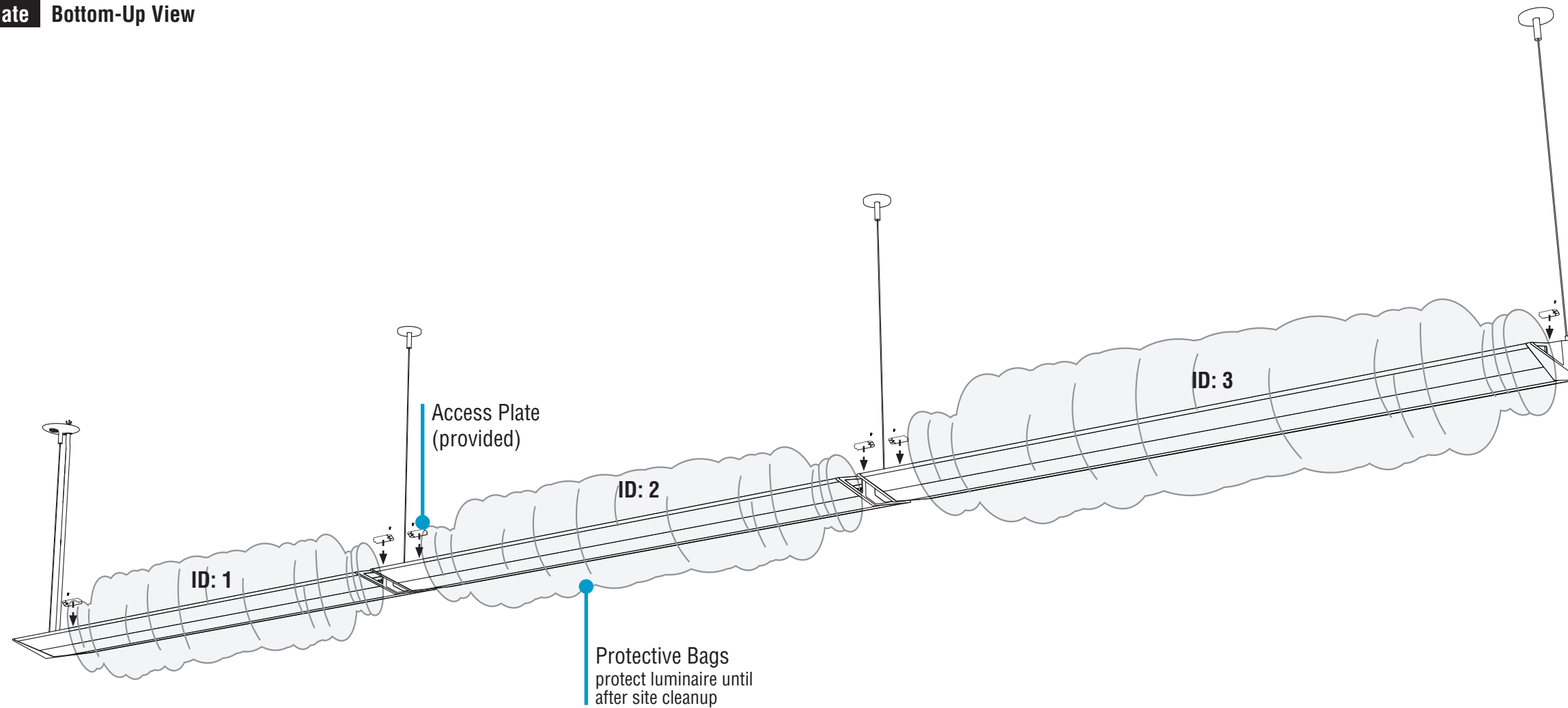

- Reinstall access plates by inserting into luminaire body and replacing the #8-18 x 5/16" screws.
- Carefully adjust protective bags to cover and protect luminaire until after site cleanup.
- Turn power on to luminaires.